



CIMCO Edit 2026 User Guide



Table of Contents

1. CIMCO Edit 2026 User Guide	6
1.1. License Information	6
1.2. Contact Information	9
2. System Requirements	10
2.1. Fast Version Simulation	10
2.2. Machine Simulation add-on	10
3. Installation	11
3.1. Locate Installation Files	11
3.2. Run Installation Program	11
3.3. Installing your License File	12
3.4. Starting the Editor	12
3.5. CIMCO Software Activation	13
3.5.1. Online Activation	13
3.5.2. Offline Activation	14
3.5.3. Re-activation	17
4. Program Tabs	18
4.1. Editor	18
4.1.1. File	18
4.1.2. File Type	21
4.1.3. Edit	22
4.1.4. Find	24
4.1.5. Bookmarks	28
4.1.6. Setup	29
4.1.7. Window	30
4.1.8. Help	31
4.2. NC Functions	31
4.2.1. Block Numbers	31
4.2.2. Insert / Remove	34
4.2.3. Transform	38
4.2.4. Info	48
4.3. NC-Assistant	51
4.3.1. NC-Assistant	52
4.3.2. Macros	55
4.3.3. Info	55
4.3.4. Setup	56
4.3.5. Multi Channel	71
4.3.6. NC-Assistant Sidebar	72
4.4. Backplot	74
4.4.1. Backplot	75
4.4.2. View	76
4.4.3. Toolpath	80
4.4.4. Tool	85
4.4.5. Solid	86
4.4.6. Control Type	90
4.4.7. Other	90
4.4.8. Find	91
4.5. File Compare	92

4.5.1. File Compare	93
4.5.2. Go To	94
4.5.3. Sync	95
4.5.4. Other	95
4.6. Transmission	96
4.6.1. Transmission	96
4.6.2. Machine	98
4.6.3. Setup	99
4.6.4. Transmit/Receive Dialogs	99
4.6.5. FTP Transfer Dialog (Split Window)	102
5. Simulation	104
5.1. Simulation Window (Fast Version)	105
5.2. Simulation Window (Standard Version)	111
5.3. Simulation Tab	114
5.3.1. Simulation Report	114
5.3.2. Settings	115
5.4. Navigation Tab	118
5.4.1. Activation and Configuration	119
5.5. Variables Tab	119
5.6. Geometry Manager Tab	121
5.7. Tool Manager	128
5.7.1. Editing an Assembly	134
5.7.2. Editing a Cutter	137
5.7.3. Editing a Holder	140
5.8. Machine Simulation	142
5.8.1. Getting started	142
5.8.2. Custom Machines	143
5.8.3. Exclusive Features	143
5.9. Presentation Viewer (Stand-alone simulation)	144
5.9.1. Ribbon / Toolbar (Top)	144
5.9.2. 3D Simulation Viewport	146
5.9.3. Tool Position and Status Panel	146
5.9.4. NC Program Panel	146
5.9.5. Axis Control Panel	146
5.9.6. Playback & Timeline Controls	147
5.10. Supported Controls	147
5.10.1. Brother	147
5.10.2. Centroid	149
5.10.3. Delectron	153
5.10.4. Fagor	154
5.10.5. Fanuc	159
5.10.6. Fidia	167
5.10.7. Flexium	169
5.10.8. Haas	170
5.10.9. Heidenhain	183
5.10.10. Hurco	189
5.10.11. Mazak	192
5.10.12. Mitsubishi	204
5.10.13. NumeriPath	208
5.10.14. OSAI	211
5.10.15. Okuma	212

5.10.16. Roeders	217
5.10.17. Siemens	217
6. DNC Setup	226
6.1. Standard Serial Protocol	228
6.1.1. Port	229
6.1.2. Transmit	232
6.1.3. Receive	235
6.1.4. Directories	237
6.1.5. Version Info	238
6.2. FTP Client Protocol	238
6.2.1. Port	239
6.2.2. Send/Receive	240
6.2.3. Version Info	242
7. Editor Setup	243
7.1. General	245
7.1.1. Editor Settings	250
7.1.2. NC-Assistant	253
7.1.3. Printing	254
7.2. File Types	257
7.2.1. Colors	259
7.2.2. Block Numbers	262
7.2.3. Load/Save	267
7.2.4. File Compare	270
7.2.5. Machine	272
7.2.6. Backplot	275
7.2.7. Scanning	278
7.2.8. Multi Channel	289
7.2.9. Tool List	297
7.2.10. Other	302
7.3. Global Colors	303
7.4. External Commands	304
7.5. Mazatrol Viewer	306
7.6. Machine Models	308
7.7. Custom Machines	310
7.7.1. Advanced Machine Configuration Editor	312
7.7.2. Machine Configuration Editor	314
7.8. Plugins	320
8. Regular Expressions	324
9. Using Editor Help	326
9.1. Using Help in Dialogs	327
10. Pending Updates to Documentation	328



EDIT

2026

1. CIMCO Edit 2026 User Guide

CIMCO Edit is the world's most popular CNC program editor. It is a reliable, full-featured editing, simulation and communication tool that allows you to work with NC programs on your PC, in a familiar Windows-based application. CIMCO Edit comes with all the essential features needed for modern NC program editing, including NC specific functions, math, transforms, drag/drop editing and more. In addition, CIMCO Edit includes file compare, mill/turn simulation, Tool Manager, NC code assistant and offers powerful add-ons for machine simulation, program management, 2D CAD/CAM, and more.

This user guide will help you get started with CIMCO Edit and learn how to use its various features and functions. You will also find information on how to customize and configure CIMCO Edit to suit your needs and preferences. Whether you are a beginner or an expert CNC programmer, CIMCO Edit will help you write error-free NC code and identify problematic toolpaths and tool motion.

We hope you enjoy using CIMCO Edit.

1.1. License Information

END USER LICENSE AGREEMENT

CONCERNING

CIMCO Software 2026 (the "Software")

WARNING! IF YOU COMPLETE THE INSTALLATION OF THIS SOFTWARE OR IF YOU ACTIVATE THE SOFTWARE, YOU ARE CONSIDERED TO HAVE ACCEPTED - AND YOU WILL BE LEGALLY BOUND BY - THIS END USER LICENSE AGREEMENT.

1. SCOPE: This End User License Agreement (the "License Agreement") sets out the terms and conditions of your license to install, access and use the standard version of the Software specified above, including upgrades and accompanying documentation. This License Agreement covers the Software in the unmodified standard version and all subsequent upgrades thereof, which is made available to you by or on behalf of CIMCO A/S, corporate ID CVR32323510, Vermundsgade 38, 3. floor, 2100 Copenhagen, Denmark (the "Licensor").

2. GRANT OF LICENSE AND EFFECTIVE DATE: Conditional upon your payment of the agreed license fee, Licensor grants you a non-exclusive, non-transferable and perpetual license (a "License") to install, access and use the Software, but only in object-code format, on the terms and conditions set forth herein. The number of Licenses you have acquired and paid for, determines the number of copies of the Software you are permitted to make and the number of end users which may access and use the Software. One (1) License covers one (1) copy of the Software and

permits one (1) end user to access and use the Software. The effective date of your License(s) is the date, where you for the first time have paid the applicable license fee.

3. TITLE AND PROPRIETARY INFORMATION: Full title to the Software shall remain with Licensor and nothing in this License Agreement shall be construed as a transfer of Licensor's title to the Software to you or to any third party. If you install the Software you automatically acknowledge and accept that the Software represents valuable trade secrets to Licensor, and that you must keep and use the Software in confidence and in accordance with the terms and conditions of this License Agreement.

4. REPRODUCTION OF SOURCE CODE: You agree not to disassemble, reverse compile, or reverse engineer the Software or any part thereof, or take any other action in order to reproduce the source code of the Software, except as expressly permitted in article 6 of Directive 2009/24/EC of the European Parliament and of the Council of 23 April 2009 on the legal protection of computer programs as incorporated into Danish law by article 37 of the Danish Act No. 1144 of October 23, 2014 on Copyrights (in Danish "Ophavsretsloven"). Therefore, the License includes a limited right for you as the Licensee to reproduce the source code of the Software on the following conditions, which shall all be fulfilled at the relevant time: (a) reproduction of the source code is indispensable to obtain the information, which is necessary to achieve interoperability between the Software and other programs, (b) the task of reproduction of the source code is performed by you or by another person having a right to use the Software, or on your behalf by a person authorized to do so; (c) the information necessary to achieve interoperability have not previously been readily available to you; and (d) reproduction of source code is confined to those parts of the Software which are necessary in order to achieve interoperability. You shall not under any circumstances (e) use information obtained through reproduction of the source code of the Software for any other purpose than to achieve the interoperability of the Software; (f) give such information to others, except when necessary to achieve the desired interoperability of the Software; or (c) use such information for the development, production, or marketing of a software program substantially similar to the Software in its expression, or for any other acts which infringe Licensor's copyright.

5. COPYING THE SOFTWARE: You agree not to copy the Software, except as expressly permitted in the articles 4 and 5 of Directive 2009/24/EC of the European Parliament and of the Council of 23 April 2009 on the legal protection of computer programs as incorporated into Danish law by article 36 of the Danish Act No. 1144 of October 23, 2014 on Copyrights (in Danish "Ophavsretsloven"). Therefore, the License includes a limited right for you as the Licensee (a) to make such number of internal copies of the Software, which are strictly necessary to ensure the Software performs in accordance with its objectives; and (b) to make an internal back-up copy of the Software, if, and to the extent, this is necessary for your use of the Software.

6. TERMINATION AND EFFECTS OF TERMINATION: You may terminate this License Agreement upon thirty (30) days written notice to Licensor. Licensor may immediately terminate any or all Licenses without further obligation or liability (a) if you fail to pay the applicable license fee or any other amount due hereunder and you continue to be delinquent for a period of thirty (30) days after the last day on which payment was due; or (b) if a petition alleging insolvency is filed by or against you, or a receiver is appointed for any part of your business, or your assets are assigned for the benefit of your creditors; or (e) if you commit any other breach of this License Agreement and fail to remedy such breach within thirty (30) days after written notice by Licensor of such breach, or (d) if you violate anyone of the Articles 3, 4, or 5 herein. Upon termination of this License Agreement or any License granted hereunder, you shall immediately cease using the Software and without delay un-install and destroy all copies of the Software and all related documentation. Termination of this License Agreement or any License granted hereunder shall not release you from the obligations of the Articles 3, 4 and 5 herein. The termination of this License Agreement shall not affect the survival of the representations, warranties, and covenants contained herein.

7. INDEMNIFICATION OF LICENSOR: You agree to indemnify and hold harmless Licensor, its distributors and its retailers and each of their respective officers, directors, and employees against any and all losses, liabilities, expenses (including reasonable attorneys' fees) suffered or incurred by them by reason of any claim, suit or proceedings arising out of or in connection with: (a) any content, information, or other materials posted, provided, uploaded, submitted, shared, published, distributed, made available, accessible or usable on, to, from or through the Software ("User Content"); or (b) any illegal or damaging usage of User Content, such as, but not limited to, usage infringing upon intellectual property rights or violating trade secrets or other rights, or causing death or bodily injury or damage to tangible assets or real property; or (c) any breach of or failure by you to comply with this License Agreement; or (d) any other use of the Software made by you (or by anyone who accesses the Software through you).

8. DISCLAIMER OF ALL WARRANTIES: EXCEPT FOR THE EXPRESS LIMITED WARRANTY PROVIDED IN THIS LICENSE AGREEMENT, IF ANY, AND TO THE MAXIMUM EXTENT PERMITTED BY APPLICABLE LAW, LICENSOR MAKES, AND YOU (IN YOUR CAPACITY OF LICENSEE) RECEIVE, NO WARRANTIES, REPRESENTATIONS, OR

CONDITIONS OF ANY KIND, EXPRESS OR IMPLIED (INCLUDING, WITHOUT LIMITATION, ANY IMPLIED WARRANTIES OF MERCHANTABILITY, FITNESS FOR A PARTICULAR PURPOSE, OR NON-INFRINGEMENT, OR WARRANTIES OTHERWISE IMPLIED BY STATUTE OR FROM A COURSE OF DEALING OR USAGE OF TRADE) WITH RESPECT TO THE LICENSED SOFTWARE. ANY STATEMENTS OR REPRESENTATIONS ABOUT THE LICENSED SOFTWARE AND ITS FEATURES OR FUNCTIONALITY IN ANY MATERIALS PROVIDED TO OR IN ANY COMMUNICATION WITH YOU ARE FOR INFORMATION PURPOSES ONLY, AND DO NOT CONSTITUTE A WARRANTY, REPRESENTATION, OR CONDITION. WITHOUT LIMITING THE FOREGOING, LICENSOR DOES NOT WARRANT THAT THE OPERATION OR OUTPUT OF THE LICENSED SOFTWARE WILL BE UNINTERRUPTED, ERROR-FREE, SECURE, ACCURATE, RELIABLE, OR COMPLETE, WHETHER OR NOT UNDER SUPPORT BY LICENSOR OR ANY THIRD PARTY. NOTHING IN THE FOREGONG SHALL RESTRICT THE EFFECT OF WARRANTIES OR CONDITIONS WHICH MAY BE IMPLIED BY LAW AND WHICH CANNOT BE EXCLUDED, RESTRICTED OR MODIFIED NOTWITHSTANDING A CONTRACTUAL RESTRICTION TO THE CONTRARY.

9. LIMITATION OF LICENSOR'S LIABILITY: IN NO EVENT WILL LICENSOR HAVE ANY LIABILITY (DIRECTLY OR INDIRECTLY) FOR ANY INCIDENTAL, SPECIAL, INDIRECT, CONSEQUENTIAL, OR PUNITIVE DAMAGES, FOR LOSS OF PROFITS, USE, REVENUE, DATA, OR FOR BUSINESS INTERRUPTIONS. IN ADDITION, THE MAXIMUM LIABILITY OF LICENSOR ARISING OUT OF OR RELATING TO THE LICENSED SOFTWARE WILL NOT EXCEED AN AMOUNT CORRESPONDING TO THE AGGREGATE LICENSE FEES PAID OR PAYABLE BY LICENSEE FOR THE LICENSES COVERED BY THE LICENSE AGREEMENT. THE LIMITATIONS OF LIABILITY IN THIS ARTICLE 9 WILL APPLY TO THE EXTENT PERMITTED BY APPLICABLE LAW TO ANY DAMAGES OR OTHER LIABILITY, HOWEVER CAUSED AND REGARDLESS OF THE THEORY OF LIABILITY, WHETHER DERIVED FROM CONTRACT, TORT (INCLUDING, WITHOUT LIMITATION, NEGLIGENCE), OR OTHERWISE, EVEN IF LICENSOR HAS BEEN ADVISED OF THE POSSIBILITY OF SUCH LIABILITY AND REGARDLESS OF WHETHER THE LIMITED REMEDIES AVAILABLE HEREUNDER FAIL OF THEIR ESSENTIAL PURPOSE. ALSO, YOU ACKNOWLEDGE AND AGREE THAT THE LICENSE FEES PAID BY YOU ARE BASED ON AND REFLECTIVE OF THE ALLOCATION OF RISK CONTEMPLATED BY THIS ARTICLE 9 AND THAT THE LIABILITY LIMITATIONS HEREIN ARE AN ESSENTIAL ELEMENT OF THIS LICENSE AGREEMENT.

10. SALE OF LICENSES TO THE UNITED STATES GOVERNMENT: For U.S. Government procurements, the Software is deemed to be commercial computer software as defined in FAR 12.212 and subject to restricted rights as defined in FAR Section 52.227-19 "Commercial Computer Software - Restricted Rights" and DFARS 227.7202, "Rights in Commercial Computer Software or Commercial Computer Software Documentation", as applicable, and any successor regulations. Any use, modification, reproduction release, performance, display or disclosure of the Software by the U.S. Government will be solely in accordance with license rights and restrictions described therein.

11. SEVERABILITY: Should any provision of this License Agreement be invalid, ineffective, or unenforceable, under present or future laws, the remainder of the provision shall remain in full force and effect and shall in no way be affected, impaired or invalidated.

12. ENTIRE AGREEMENT: You acknowledge that you have read this License Agreement before you complete installation of the Software or before you access and start using the Software and you acknowledge and agree that this License Agreement is the complete and exclusive statement of the agreement between us, and that it supersedes all prior proposals and understandings, oral and written, relating to the Software licensed pursuant to this License Agreement. This License Agreement shall not be modified or rescinded except in writing signed by both of us. Notwithstanding the aforementioned sentences, you acknowledge and accept that the licensed Software may contain or be accompanied by third-party software, data, or other materials that are subject to and provided in accordance with third-party license terms that are in addition to or different from the terms set forth in this License Agreement. Such third-party license terms may be included or referenced to or with such third- party software, data, or other materials (e.g., in the "About box"), or at a web page specified by Licensor (the URL for which may be obtained on request to Licensee). You hereby agree to comply with such third-party terms as the case may be.

13. CHOICE OF LAW AND VENUE: You acknowledge and accept that this License Agreement and all aspects of the agreement, including the construction, interpretation, and validity of the agreement, shall be exclusively governed by Danish law, except its conflict of laws rules. Any dispute between us related to this License Agreement and which cannot be otherwise settled by our agreement, must be brought before the courts of Denmark to the exclusion of the courts of any other jurisdiction.

1.2. Contact Information

CIMCO A/S
Vermundsgade 38A, 3
2100 Copenhagen Ø
Denmark

Tel: +45 4585 6050
Fax: +45 4585 6053
E-mail: info@cimco.com
Web: www.cimco.com

CIMCO Americas, LLC
1980 N Atlantic Ave Ste 229
Cocoa Beach, FL 32931
USA

Tel: +1 704 644 3587
Fax: +1 704 943 0514
E-mail: info@cimcous.com
Web: www.cimco.com

2. System Requirements

This page details the official CIMCO system requirements and hardware support.

Specification	Minimum
Operating system	Windows® 8 minimum (Only 64 bit version is supported)
CPU	Intel Core 2 Duo or AMD Athlon @ 1.6 GHz - or higher
Memory	At least 2 GB RAM
Hard drive	2 GB of disk space for the installation of the full suite
Display	OpenGL (3.3 and later) compatible graphics card (required for Backplot/Solid Animation option in CIMCO Edit) Monitor with minimum resolution of 1024 x 768 pixels
Network	Network adapter with TCP/IP enabled (required for network licensing or Client/Server solutions)
Input	Standard keyboard Mouse with 2 or 3 buttons
Software	Microsoft® Visual C++ 2015-2019 Redistributable Microsoft® .NET Framework 4.5 (All required redistributables are included within the installer) A valid license keyfile

2.1. Fast Version Simulation

Requirements for *Fast Version* simulation introduced in CIMCO Edit 2022.01.11. ([Fast version](#))

Specification	Minimum	Recommended
CPU	2.3GHz, Dual core	Recommended: 3.2GHz, Octa core (or better)
GPU	2GB, Dedicated GPU, OpenGL 4.3	4GB, Dedicated GPU, OpenGL 4.3 (or better) Nvidia RTX 2060 or better.
Memory	8GB	16GB (or more)
Operating system	Windows 8, 64bit	Windows 10, 64bit

2.2. Machine Simulation add-on

Specification	Minimum	Recommended
CPU	2.3GHz, Quad core	3.2GHz, Quad core (or better)
GPU	2GB, Dedicated GPU, OpenGL 3.3	4GB, Dedicated GPU, OpenGL 3.3 (or better)
Memory	4GB	16GB (or more)
Operating system	Windows 8, 64bit	Windows 10, 64bit

Some minimum hardware requirements like CPU or RAM will depend also on the OS installed on the computer.

3. Installation

To install CIMCO Edit 2026, follow the instructions below.

Before you install or use any CIMCO product, we recommend that you verify that your computer meets or exceeds the [minimum system requirements](#).

3.1. Locate Installation Files

If you receive CIMCO Edit 2026 via a download link, memory stick, or external drive, copy the installation file to a temporary directory on the PC/Server before proceeding.

3.2. Run Installation Program

First you must log on using an account with full administrative privileges.

Start the installation program by clicking on the setup application ( CIMCOEdit_2026xxxx.exe). Now follow the instructions of the Setup Wizard that will guide you through the installation steps.

When the installation is completed, you will find a shortcut to the CIMCO Edit 2026 application in the CIMCO 2026 program group in the *Start* menu and in the desktop.



CIMCO Edit 2026 icon.

Notes on additional install options

The option *Place configuration in install directory* will place the user files (configuration, macros, tool libraries...) in the installation directory. This will allow all the users on the PC to run CIMCO Edit with the same settings.

If this option is not checked, the user files (configuration, macros, tool libraries...) will be placed in the application specific data folder for the user profile (C:\Users*username*\AppData\Roaming), so every user in the computer will run CIMCO Edit with its own user files.

More information related to this option can be found in Plugins.

3.3. Installing your License File

If you do not have a license file but wish to install an evaluation version, just proceed to the next step.

If you have received a license file from CIMCO, it should be installed by double-clicking on the file "*CustomerName-license.CimcoLicense*" after the installation is completed. This opens the CIMCO License File Viewer. Click on the button **Install license file** to install the license file. If the license file requires activation, the program will display the options for doing this. See [CIMCO Software Activation](#) for further information.

3.4. Starting the Editor

When the installation is completed and you have installed your license file, you are ready to start the editor for the first time. Click on the program icon on your desktop.



CIMCO Edit 2026.

After starting the editor, please verify that your company name is shown in the **Licensed to** field in the *About* box. If not, the license file was not installed correctly. Please repeat the point 'Installing your License File' above in order to install the license file correctly.

If you are running an evaluation version, the license name is *Demo version*.

3.5. CIMCO Software Activation

To ensure that the License File is not copied and used elsewhere, the License File can be locked to a specific computer using an activation process. Once the system is activated, the License File cannot be used on another system unless the activation is reset.

The software activation process is not needed for temporary license files.

3.5.1. Online Activation

After selecting the license file that CIMCO Edit will use, if the license file requires activation, the program will display the following message:

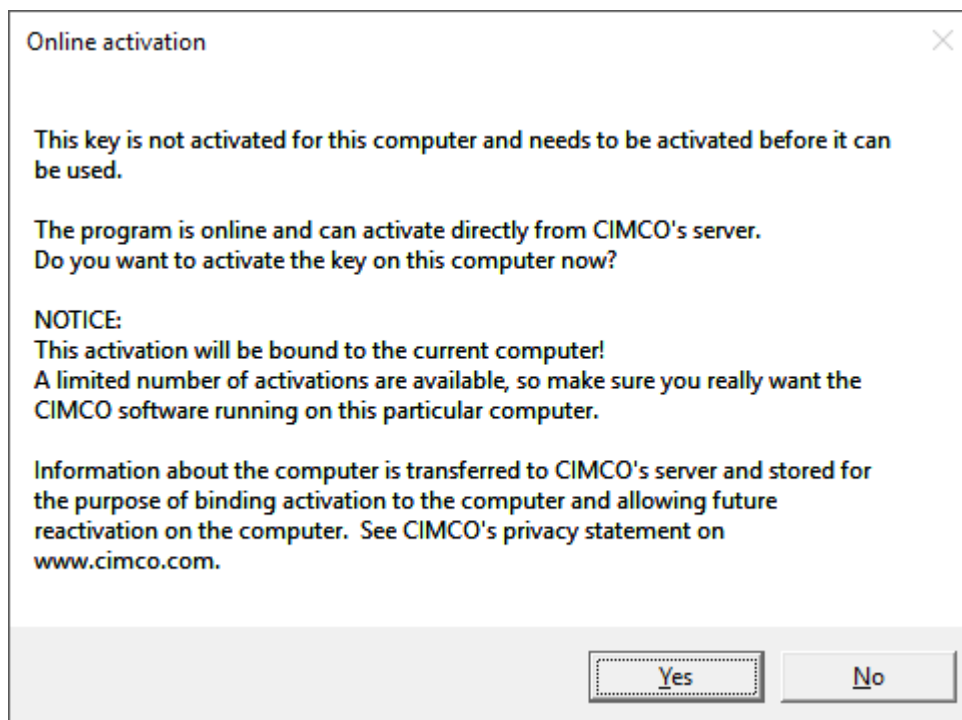

Software activation dialog.

If the computer running CIMCO Edit has access to the Internet, just click the **Yes** button and the activation process will be done automatically.

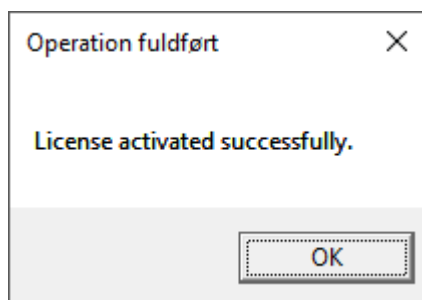

Software activation completed successfully.

3.5.2. Offline Activation

If the computer running CIMCO Edit is not connected to the Internet, then the following dialog will be displayed:

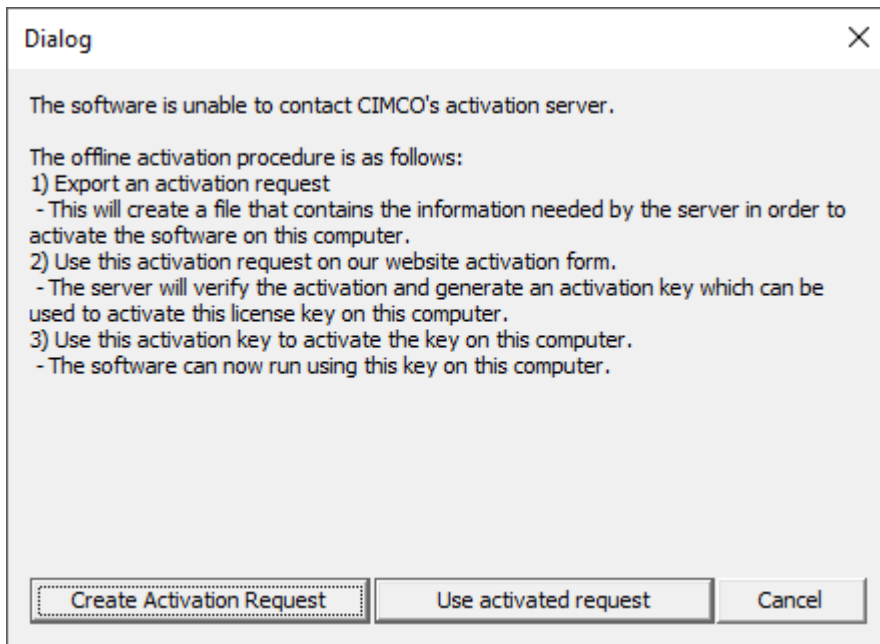

Software activation dialog.

Click on the button **Create Activation Request**. This will generate an activation request file (.request) that contains information from the computer in order to uniquely identify the system. Give to this file any filename, select where you want to save this file and click **Save**.

The activation can only be done contacting the CIMCO's activation server, so copy the generated .request file to a portable device and proceed to a computer with Internet connection.

Open a web browser and go to the Activation page on the CIMCO web site at www.cimco.com/support/activate-software

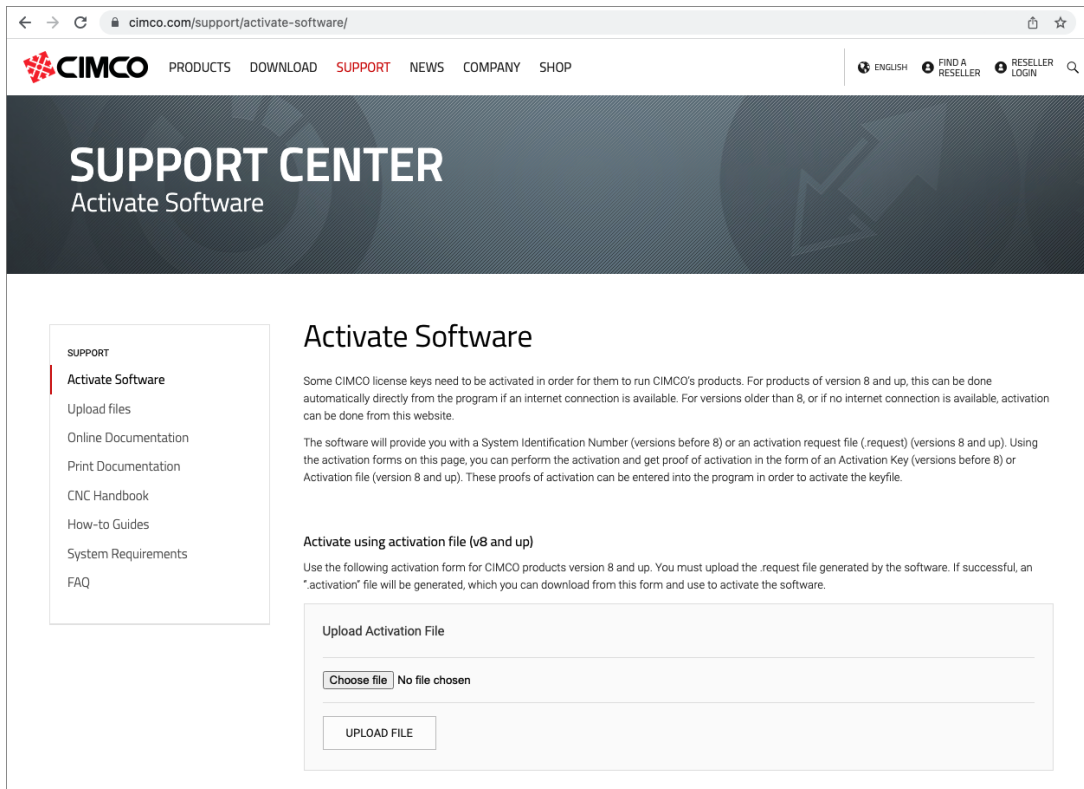

Software Activation web page.

Click in the **Choose File** button and navigate to the activation request file (.request). Once the file is selected, click the **Upload File** button.

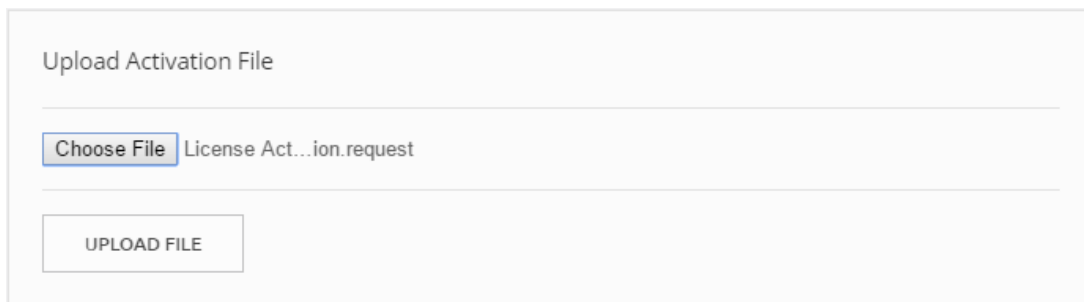

Upload Activation File.

The server will verify the activation request and will generate an Activation File. If any error occurs during the activation, it will be displayed in the Activation box. If the activation is successful, a link to download the Activation File will be shown.

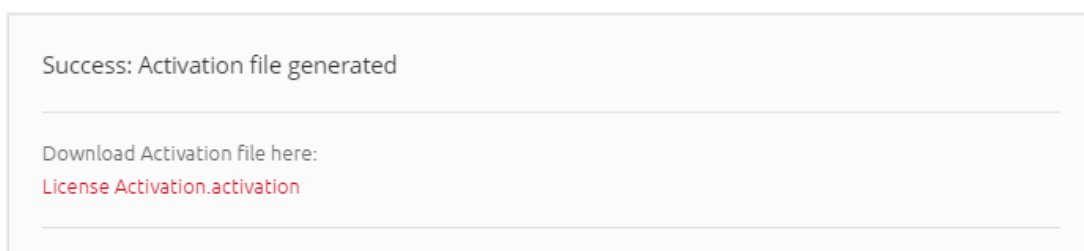

Download Activation File.

Save the generated Activation File (.activation) and go back to the computer running CIMCO Edit which we want to activate. In the software activation dialog, click now in the **Use activated request** button. Select the

Activation File (.activation) and click **Open**. The software should be now activated and ready to use.

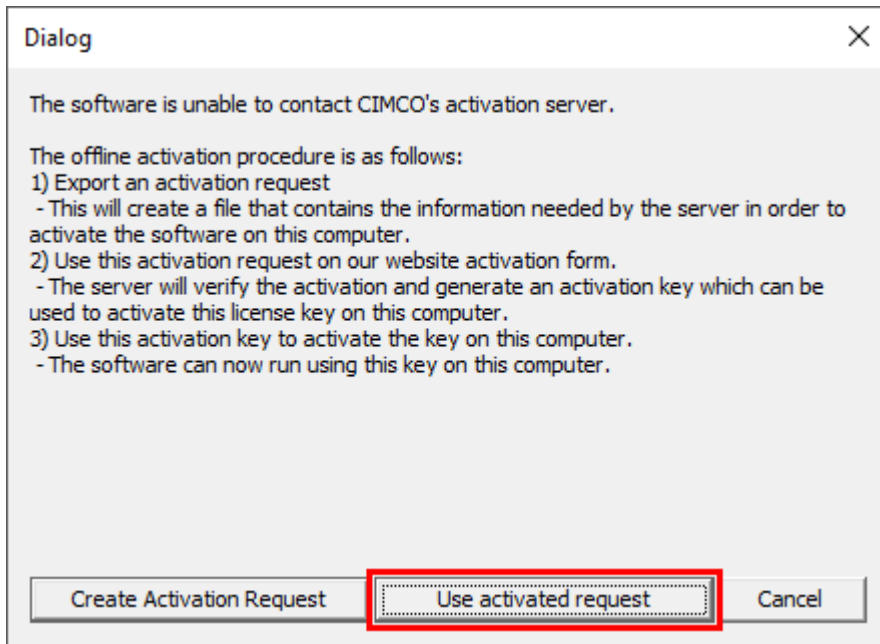

Use activated request file downloaded from the CIMCO web site.

After the activation is completed, you can see information about the activation in the License File Viewer.

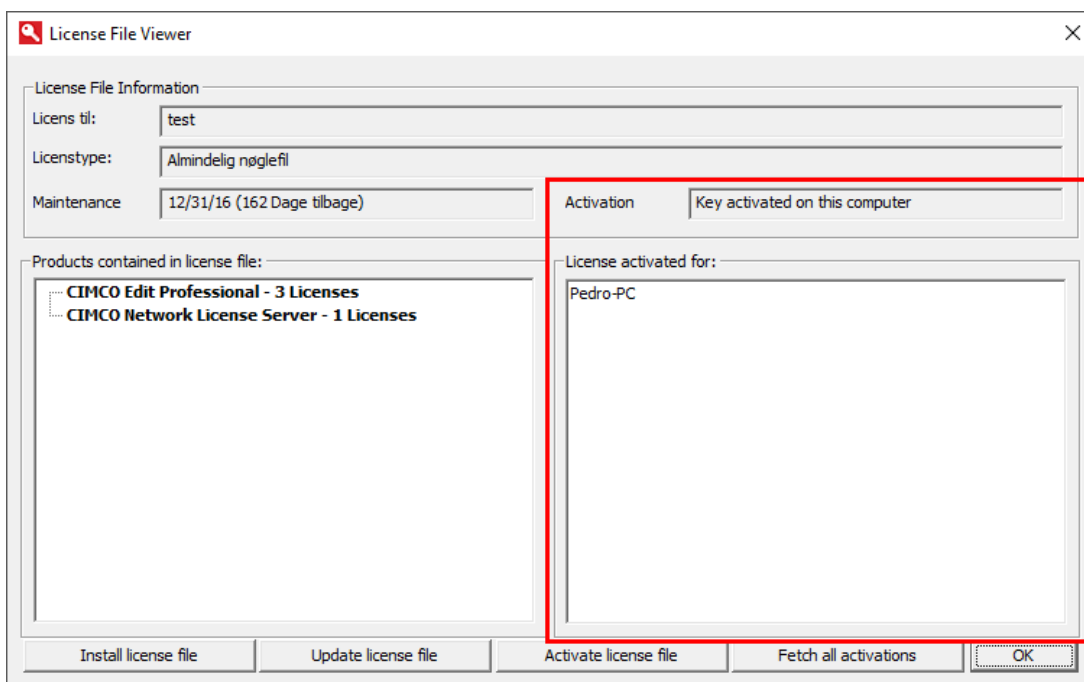

Activation information.

The License File can also be activated directly from the License File Viewer. Once the button **Activate license file** is pressed, the process is the same as described for Online Activation or Offline Activation depending if the computer is connected to the Internet or not.

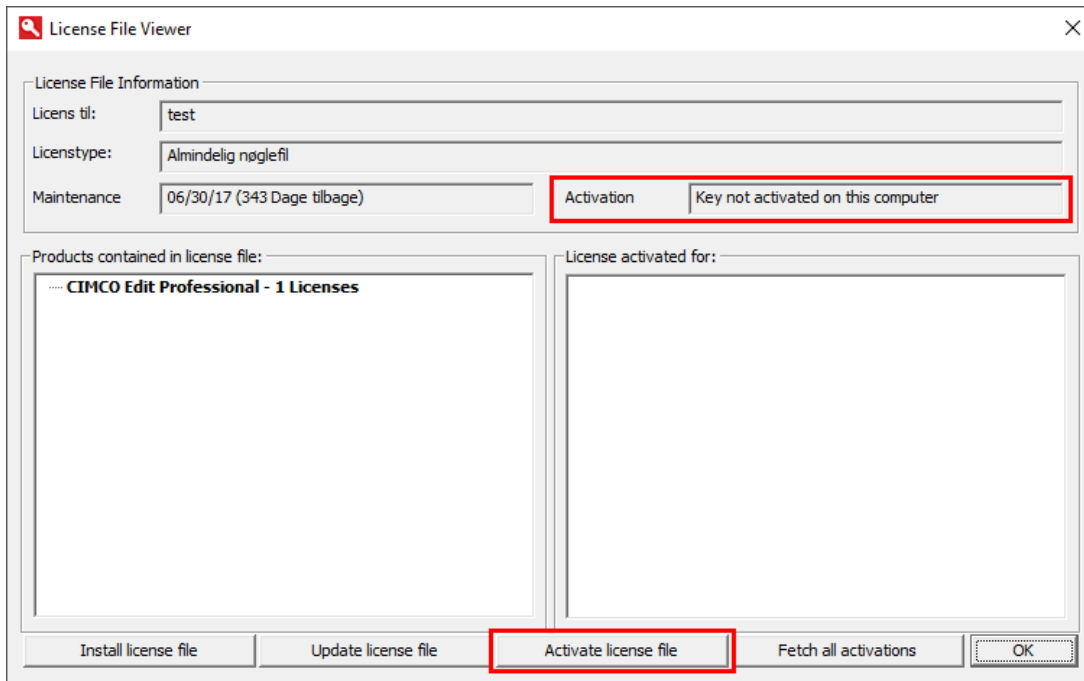

License activation from the License File Viewer dialog.

3.5.3. Re-activation

If the computer running CIMCO Edit needs to be replaced, a new software activation is needed, and the activation needs to be reset before going through the activation process in the new system or the following error will be displayed. Please contact your reseller or CIMCO Support in order to get your activation reset.

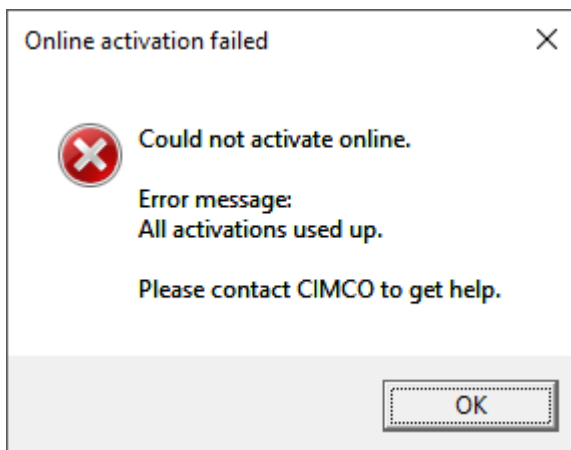

License File already activated.

If the OS needs to be re-installed or upgraded, a new software activation may be required. But since the computer hardware is unchanged (same CPU, hard drive, MAC address...) it should not be necessary to contact your reseller or CIMCO Support to reset the activation.

4. Program Tabs

The functions in CIMCO Edit 2026 are activated using the appropriate icons on the Ribbon bar. The options are organized into logical groups under tabs.

If the function can be activated through the Ribbon bar or a keyboard shortcut, the icon or the shortcut is displayed next to the command name.

4.1. Editor

This section describes the options in the **Editor** tab.

4.1.1. File

This section describes the options in the **File** menu.



File menu.

Menu options



Select this option to create an empty program/file, ready for input.



Select this option to open a file.



The *Advanced Open* file dialog lets you to locate files by specifying search criteria on file name, file content, and created/modified dates. Click the down arrow of the *Open* icon to access this option.

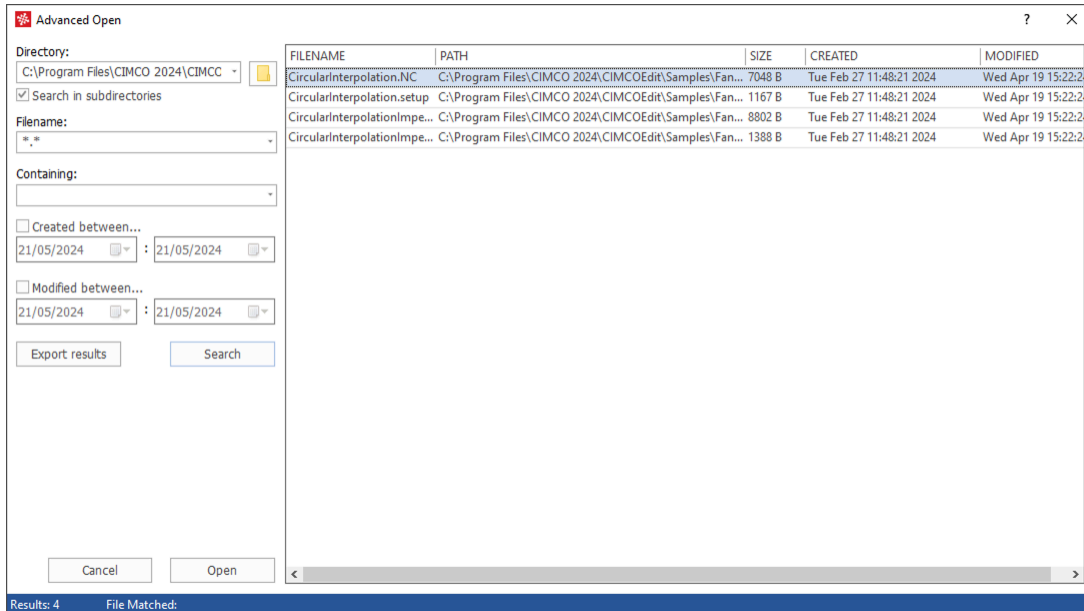

Advanced Open File dialog.

Recent

A list of recently used files. Click the down arrow of the Open icon to open recently used files.

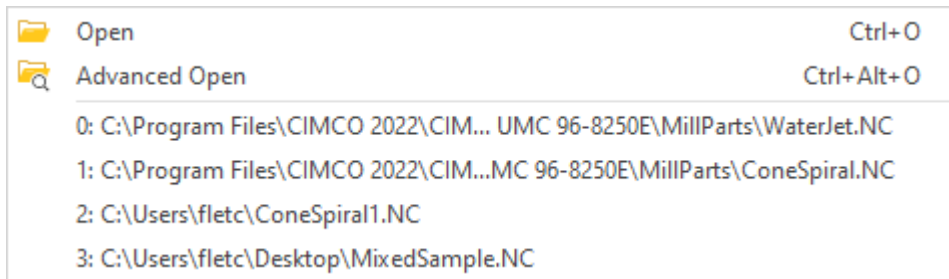

Recent list.

Close / Ctrl+F4

Closes the current window. You will be prompted to save changes if the file has been modified.

Close All

Closes all open windows. You will be prompted to save changes for all modified files. Click the down arrow of the Close icon to access this option.

Save / Ctrl+S

Saves the current CNC program.

Save All

Saves all open CNC programs under their current names. Click the down arrow of the Save icon to access this function.

Save As

Saves the current CNC program under a new name.

Save as associated file

Saves the current CNC program in CIMCO NC-Base. When selected, the user will be prompted to select *Machine*, *Program Name* and enter a *filename*. The program will then be saved and associated with the selected program in CIMCO NC-Base.

Print / Ctrl+P

Prints the current CNC program. If you want to print a part of a program, mark the area of interest and choose **Print**.

Printer Setup

The dialog window for printout configuration is opened. Click the down arrow of the Print icon to open this option. Please refer to section Printing for more details.

Global setup

This option lets you configure the general program settings of CIMCO Edit, also accessible through the icon . Please refer to section Editor Settings for more details.

Most of the **File** functions described above can also be reached through the general **File** menu.

4.1.2. File Type

This section describes the options in the **File Type** menu.

The **File Type** options determine how renumbering is performed, how tool changes are identified, Backplot settings, colors, where files are saved, etc.

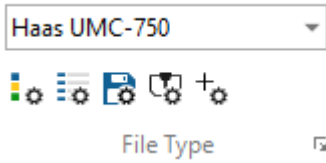

File Type menu.

Menu options

File Type

Use this dropdown list to select a file type. The file type determines the coloring, syntax, etc.

Colors

Opens the [Color Settings](#) in the *Editor Setup* for the selected file type. Use this to define the color highlighting for the file type.

Block Numbering

Opens the [Block Numbers](#) dialog in the *Editor Setup* for the selected file type. Use this to configure block numbering.

Load/Save (Directories and Extensions)

Opens the [Load/Save](#) dialog in the *Editor Setup* for the selected file type. Use this to configure directories and extensions.

Machine Templates

Opens the [Machine](#) dialog in the *Editor Setup* for the selected file type. Use this to configure machine template specific parameters.

Other Settings

Opens the [Other](#) dialog in the *Editor Setup* for the selected file type. Use this to configure additional machine settings.

Setup File Type

Opens the [File Types](#) dialog in the *Editor Setup*. Use this dialog to add new or configure existing file types.

4.1.3. Edit

This section describes the options in the **Edit** menu. These are mostly standard options for editing text plus options for appending text from external files.



Edit menu.

To select a specific segment of text, click and hold the left mouse button at the desired starting point, then drag the cursor to the end point. The selection will be visually represented by a change in background color, signifying the selected area. For details on color indications, refer to the [Global Colors](#).

Menu options

 **Copy / Ctrl+C**

Copies the selected text to the clipboard.

 **Cut / Ctrl+X**

Deletes the selected text and saves it on the clipboard.

To paste the cut-out selection at another location in the file, place the cursor there and choose the command *Paste*.

 **Paste / Ctrl+V**

Inserts the clipboard contents, after *Copy* or *Cut*, at the current cursor position.

 **Select All / Ctrl+A**

Selects all lines in the file.

 **Undo / Ctrl+Z**

Undo the last operation.

 **Redo / Ctrl+Y**

Redo the last *Undo* operation. You can *Redo* all *Undo* operation since the file was last opened.

 **Mark/Delete range / Ctrl+M**

When selecting **Mark/Delete range**, the following dialog appears:

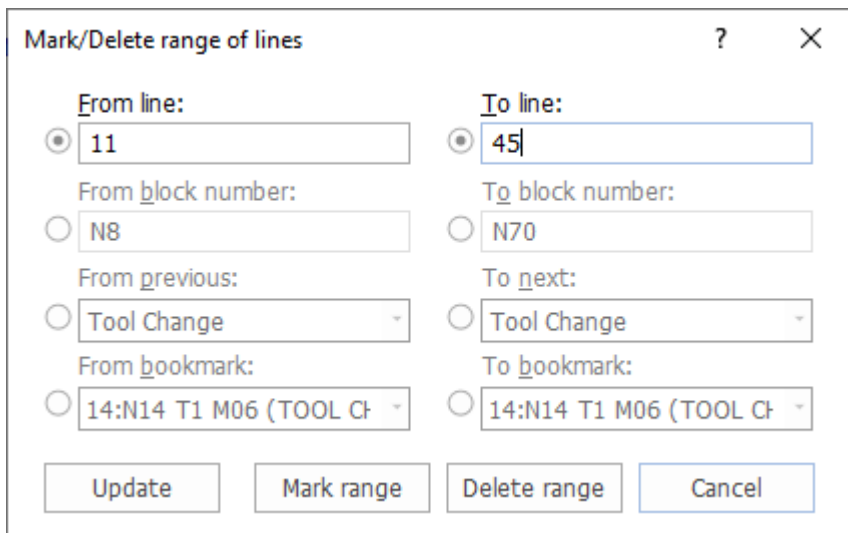

The dialog box is titled "Mark/Delete range of lines" and contains the following fields and options:

<input checked="" type="radio"/> From line:	<input type="text" value="11"/>	<input checked="" type="radio"/> To line:	<input type="text" value="45"/>
<input type="radio"/> From block number:	<input type="text" value="N8"/>	<input type="radio"/> To block number:	<input type="text" value="N70"/>
<input type="radio"/> From previous:	<input type="text" value="Tool Change"/>	<input type="radio"/> To next:	<input type="text" value="Tool Change"/>
<input type="radio"/> From bookmark:	<input type="text" value="14:N14 T1 M06 (TOOL CH"/>	<input type="radio"/> To bookmark:	<input type="text" value="14:N14 T1 M06 (TOOL CH"/>

Buttons: Update, Mark range, Delete range, Cancel

Mark/Delete dialog.

This dialog allows you to specify a range of lines or block numbers to be updated, selected or deleted. It is possible to make a special selection (or deletion) from a tool change, feed rate or spindle speed value up till the next.

You can also access this dialog from the [Insert/Remove](#) menu under the NC Functions tab.

 **Append File**

Appends a file to the end of the current CNC program.

 **Insert File**

Inserts a file into the current window at the cursor position.

4.1.4. Find

This section describes the options in the **Find** menu. These options are used for searching or jumping to a location in the current file.

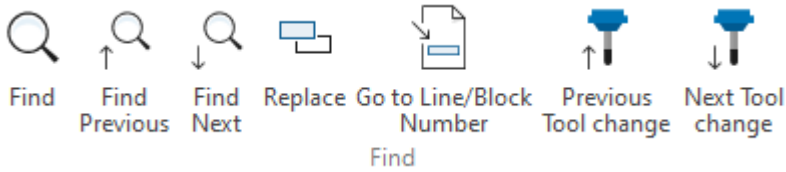

Find menu.

Menu options



Click this option to open the *Find* dialog.

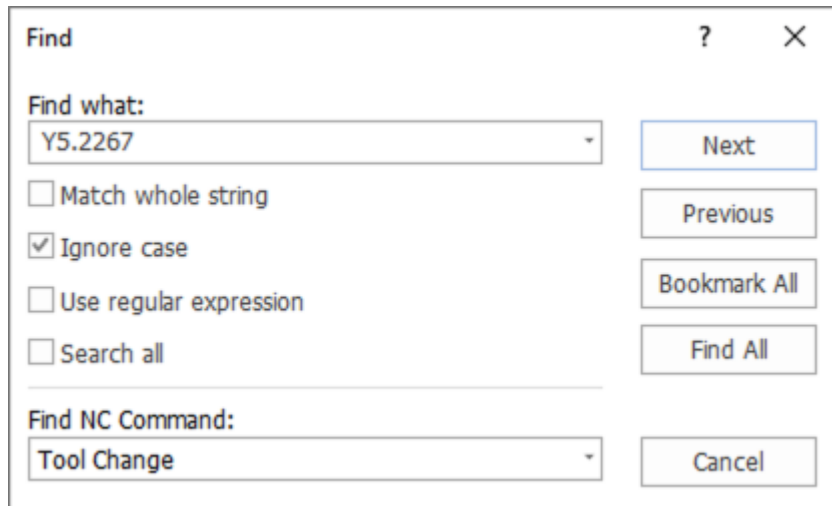

Search dialog.

- **Find what:** Enter the text to search for in the *Find what* field. If a text selection was made before clicking the *Find* option, this will be auto-inserted in the *Find what* field.
- **Match whole string:** Select this option to only match the exact string in the *Find what* field.
- **Ignore case:** Select this option to ignore if letters are uppercase or lowercase.
- **Use regular expression:** Select this option to interpret the text in the *Find what* field as a Regular Expression such as `\((.*?)\)` - to find the text between ((and)). See [Regular Expressions](#) for more information.
- **Search all:** Select this option to search through all open files.

- **Find NC Command:** Use this dropdown to search for a Tool Change, Feedrate or Spindle Speed. How these are identified is configured in the *Editor Setup* under the [File Types](#) dialog.
- **Next/Previous:** Use these buttons to go to the next or previous search result.
- **Bookmark All:** Click this button to create *Bookmarks* from all search results.
- **Find All:** Click this button to show an overview of all matching search results in a dialog. Clicking a result in this dialog, selects it in the file.



Find Previous / Shift+F3

Finds the previous occurrence of the specified search string in the file.



Find Next / F3

Finds the next occurrence of the specified search string in the file.



Replace / Ctrl+H

Click this option to replace a specified string in the file with another string.

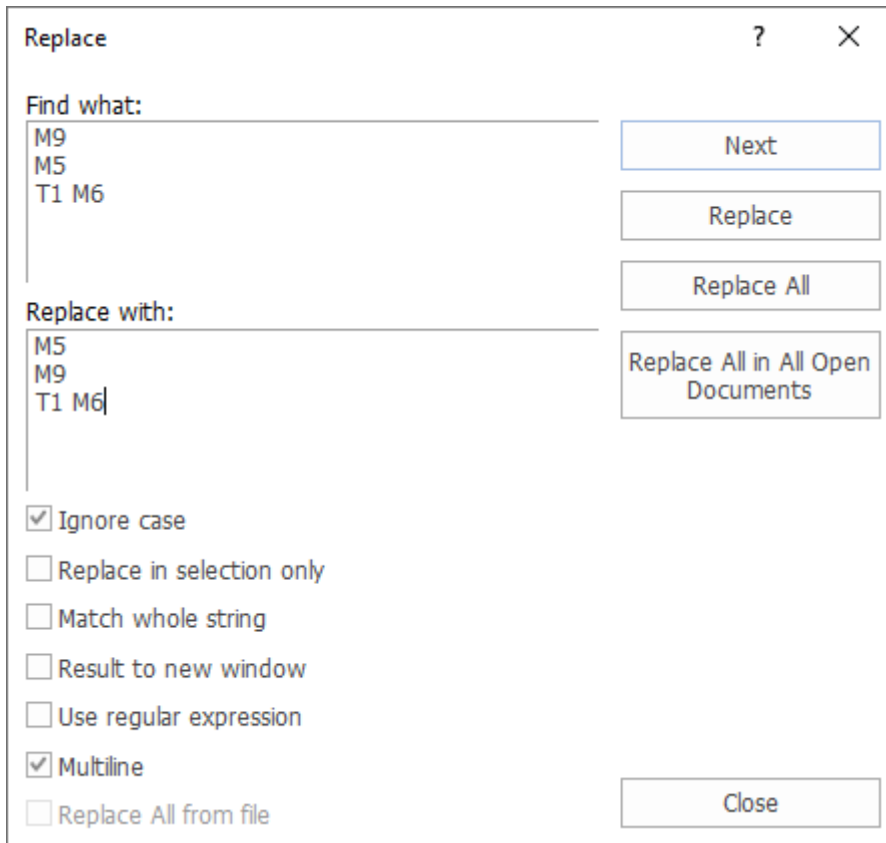

Replace dialog with option *Multiline* enabled.

- **Find what:** Enter the text string that should be replaced. If *Multiline* is enabled, more lines of text can be entered.
- **Replace with:** Enter the text string to replace with. If *Multiline* is enabled, more lines of text can be entered.
- **Ignore case:** Select this option to ignore if letters are uppercase or lowercase.
- **Replace in selection only:** Select this option to only perform the replace operation on the selected lines.
- **Match whole string:** Select this option to only match the exact string in the *Find what* field.
- **Result to new window:** Select this option to create a new, duplicate document with the replaced text.
- **Use regular expression:** Select this option to interpret the text in the *Find what* field as a Regular Expression.
- **Multiline:** Select this option allow multiple lines in the *Find what* and *Replace with* fields.
- **Replace All from File:** Select this option to import one or more replace statements from an external

file. Each line in the external file should define a find/replace pair. Once selected, a field will appear to enter the *Delimiter* used in the external file (such as a semi-colon for the pair T1;T10). Finally, click the *Replace All* button, select the file with the find/replace statements and press OK.

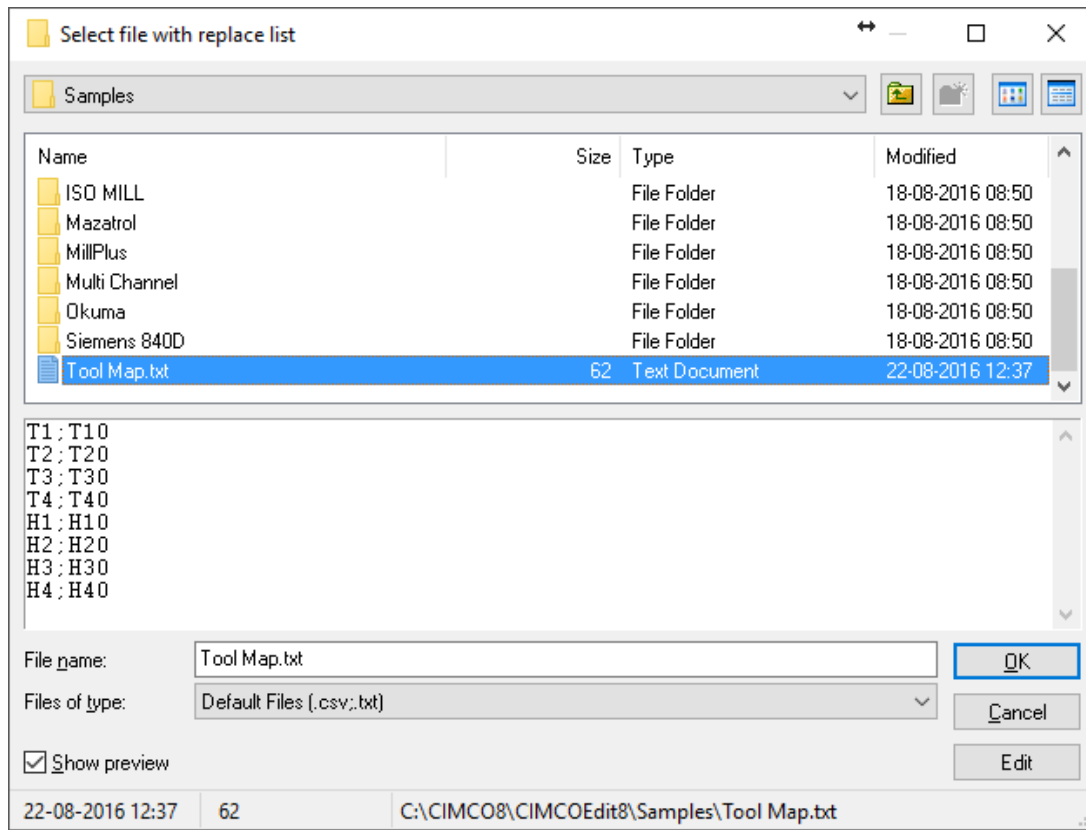

Dialog to select the replace list.



Go to Line/Block Number / Ctrl+J

Move cursor to line or block number in the current file.



Next Tool Change

Move cursor to next tool change.



Previous Tool Change

Move cursor to previous tool change.

4.1.5. Bookmarks

This section describes the options in the **Bookmarks** menu. These allow you to bookmark lines and locations in a document.

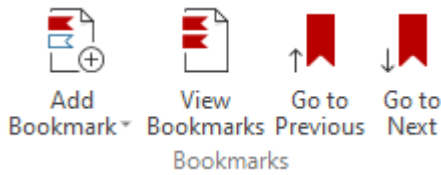

Bookmarks menu.

Bookmark indicators are shown by highlighting the line number. Make sure the *Show line numbers* option is enabled in the [Editor Settings](#) to see the bookmarks.

Menu options



View Bookmarks

Click this option to open the *Bookmarks* dialog which shows all the bookmarks in all the currently open documents. Use the buttons to delete, clear (remove) or jump to a bookmarked location in a document.

Bookmarks will only show up in this dialog if the document has been saved.

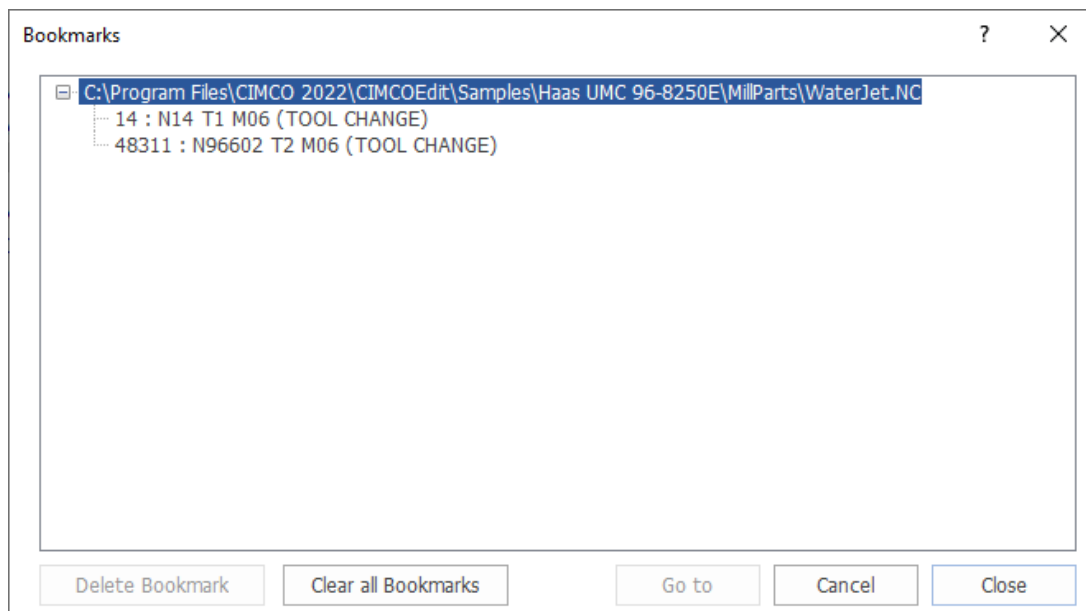

Bookmarks dialog.



Go to Previous / Shift+F5

Jumps to the previous bookmark found in the document.
CIMCO Edit 2026 User Guide



Go to Next / F5

Jumps to the next bookmark found in the document.



Add Bookmark (Remove Bookmark) / F2

Click this option to create a bookmark on the selected line. Use the Add Bookmark dialog to give a name to the bookmark.

Add Bookmark dialog.

Add Bookmark dialog.

If there is already a bookmark on the selected line, this option will display *Remove Bookmark* instead. Click this to remove the bookmark.



Toggle Indicators

Toggles display of bookmark indicators.

4.1.6. Setup



Setup

Click this to enter the [Editor Setup](#) dialog.

4.1.7. Window

This section describes how the open documents in CIMCO Edit can be visually arranged.

Click on the small *Window* dropdown at the top right corner of the Ribbon. This will open a menu with four display modes and a list of open documents.

Click on a mode to change the layout of open documents or click on a document in the list to make this the active document.



Window menu.

Menu options

Dark Theme

Select this to enable dark theme. The dark theme reduces the luminance emitted by device screens by emitting low levels of light while maintaining a high standard of usability.

Cascade

Places the open files in an overlapping cascade.

Arrange icons

Assembles the icons of the minimized documents in the lower left corner of the editor window.

Tile Horizontally

Places the open documents horizontally one after the other.

Tile Vertically

Places the open documents vertically one after the other.

4.1.8. Help

If you need help with CIMCO Edit, click on the *Help* dropdown in the upper right corner of the Ribbon. Help in CIMCO Edit is further explained in [Using Editor Help](#).

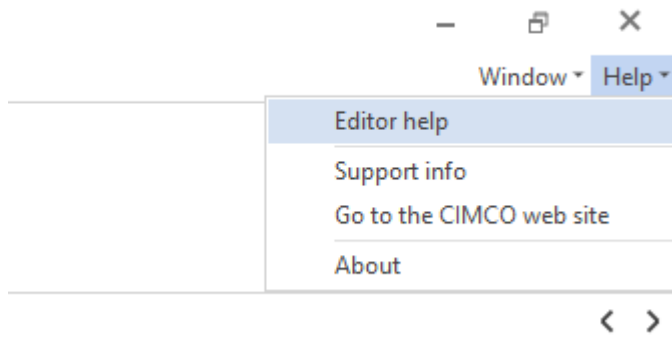

Help menu.

4.2. NC Functions

This section describes the options in the **NC Functions** tab.

4.2.1. Block Numbers

This section describes the options in the **Block Numbers** menu. This menu contains functions concerning the appearance of the CNC program. For instance the commands and the block numbers can be changed.

To configure numbering, please refer to the [Block Numbers](#) section in the Editor Setup.

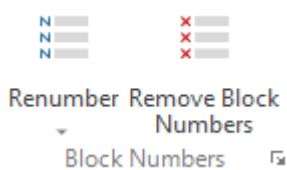

Block Numbers menu.

Menu options



Inserts block numbers in the CNC program (or renumber the block numbers if some already exist in the CNC program).

If the option *Show quick setup* is enabled in the [Block Numbers](#) section in the Editor Setup, the following dialog will appear. This allows for swift configuration of the renumbering process.

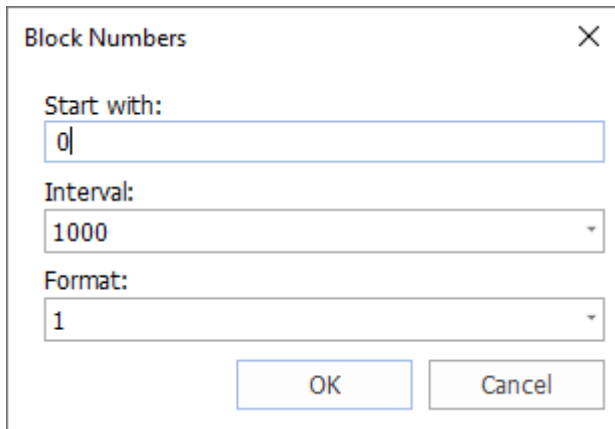

A dialog box titled "Block Numbers" with a close button (X) in the top right corner. It contains three input fields: "Start with:" with the value "0", "Interval:" with the value "1000", and "Format:" with the value "1". At the bottom, there are two buttons: "OK" and "Cancel".

Advanced Renumbering

Advanced Renumbering allows for more complex and nuanced renumbering of NC code.

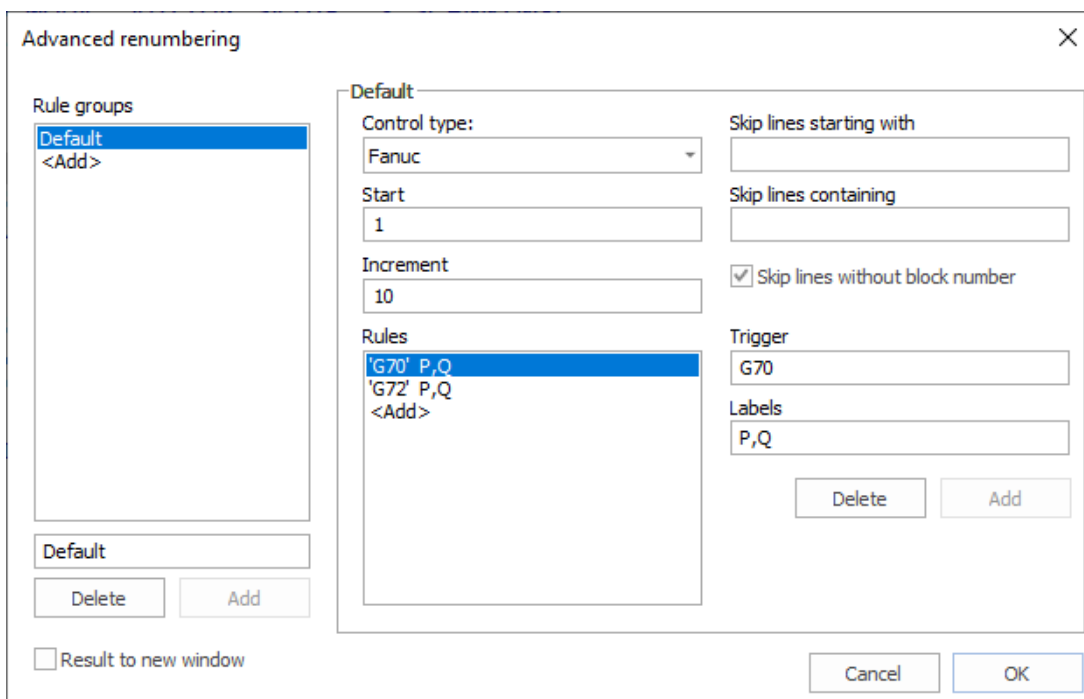

A dialog box titled "Advanced renumbering" with a close button (X) in the top right corner. It is divided into several sections:

- Rule groups:** A list box containing "Default" and "<Add>". Below it is an input field with "Default" and "Delete" and "Add" buttons.
- Default:** A section with the following controls:
 - Control type:** A dropdown menu set to "Fanuc".
 - Start:** An input field with the value "1".
 - Increment:** An input field with the value "10".
 - Rules:** A list box containing "'G70' P,Q", "'G72' P,Q", and "<Add>".
 - Skip lines starting with:** An empty input field.
 - Skip lines containing:** An empty input field.
 - Skip lines without block number:** A checked checkbox.
 - Trigger:** An input field with the value "G70".
 - Labels:** An input field with the value "P,Q".
 - "Delete" and "Add" buttons below the Labels field.
- Result to new window:** An unchecked checkbox.
- At the bottom right, there are "Cancel" and "OK" buttons.

Advanced Renumbering dialog

- **Rule Group:** Allows you to save your renumbering setups for future use. Select a group from the *Rule groups* list to configure its settings or add a new group by selecting <Add>, entering a name in the empty field below, and clicking the Add button.
- **Control type:** Select the type of control. Different controls have different renumbering formats.
- **Start:** Enter the starting number.
- **Increment:** Enter how much to increment the numbering. If *Start* is set to 0 and *Increment* to 5, lines will be numbered 0, 5, 10, 15, etc.

- **Skip lines starting with:** Specify a list of characters or strings, separated by commas, that will instruct the renumbering process to skip a line. This ensures that lines *starting* with these specified prefixes are not renumbered. Examples could be O and %.
- **Skip lines containing:** Specify a list of characters or strings, separated by commas, that will instruct the renumbering process to skip a line. This ensures that lines *containing* these specified characters or strings are not renumbered.
- **Skip lines without block numbers:** ensures that any lines in the NC code that do not have block numbers are not renumbered. This feature is particularly useful when you want to maintain the sequence of numbered lines while ignoring those without numbers. When this option is checked, the renumbering process will continue on the next line that contains a block number, preserving the integrity of the code structure.
- **Rules:** Rules define specific conditions or patterns for the renumbering process and determine how and when the line numbers should be updated. For example, you might have a rule that renumbers lines only if they contain a certain command or pattern.
- **Trigger:** Triggers are the conditions that activate the rules. They are like the 'if' part of an 'if-then' statement. When a trigger condition is met in the NC code, the associated rule is applied. For instance, a trigger could be set to look for lines that contain a specific word or character sequence. An example of a *Trigger* could be 'G70' which a finishing cycle that often references specific line numbers or block numbers to indicate where the finishing cycle should begin and end.
- **Labels:** Labels are identifiers used within the NC code that can be referenced by rules and triggers. They often mark specific sections or commands in the code, such as loops or subroutines, and are essential for ensuring that the renumbering process respects the program's logic and structure. For the 'G70' example above, *Labels* could be P, Q where P might be used to indicate the start of a subprogram, and Q could be used to mark the end. Whenever the renumbering process encounters a G70 command, it should look for the associated P and Q labels to determine the range of lines to be renumbered. This ensures that the renumbering process respects the logical flow of the program and does not disrupt the execution of the finishing cycle.
- **Delete/Add buttons:** Select <Add> under *Rules*, fill out the *Trigger* and *Labels* fields, and click the Add button to add a new rule. Select an existing rule to delete it.
- **Result to new window:** Select this to create a new document with the renumbered NC program.



Deletes all block numbers from the CNC program.

Opens the [Block Numbers](#) configuration dialog.

4.2.2. Insert / Remove

This section describes the options in the **Insert / Remove** menu. These allow you to quickly write and edit NC programs.

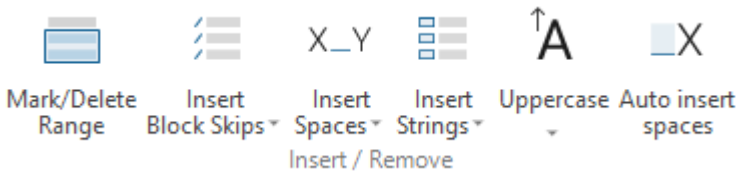

Insert/Remove menu.

Menu options

Mark/Delete Range / Ctrl+M

When clicking on **Mark/Delete Range**, the following dialog appears:

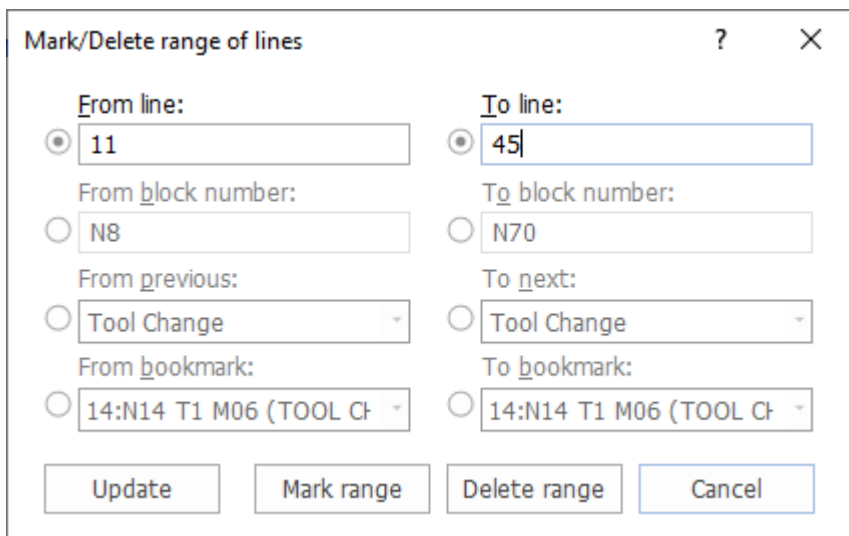

Mark/Delete dialog.

This dialog allows you to specify a range of lines or block numbers to be updated, selected or deleted. It is possible to make a special selection (or deletion) from a tool change, feedrate or spindle speed value up till the next.

You can also access this dialog from the [Edit](#) menu under the Editor tab.

Insert Block Skips

This adds a special skip-character to the start of lines. If no lines have been selected, the skip-character will be prepended to all lines. If lines have been selected, only those lines will get the character.

The block skip character can be defined in the [Machine configuration](#) dialog.

Remove Block Skips

This removes all the skip-characters from the current CNC program. Click the down arrow of the *Block Skips* option to access this option. If no lines have been selected, skip-characters will be removed from all lines. If lines have been selected, only those lines will get the skip-character removed.

X_Y Insert Spaces

Inserts space characters between the commands in the CNC program, where there is no space character between two commands. Existing space characters are left as they are.

X|Y Remove Spaces

Deletes all the space characters and tab signs from the CNC program (whitespace characters). Click the down arrow of the *Insert Spaces* option to access this option.

Remove Empty Lines

Removes all the empty lines from the NC program. Click the down arrow of the *Insert Spaces* option to access this option.

Remove Comments

Removes all the comments from the NC program - written in parentheses or with the *Comment start/end* characters defined in the [Machine configuration](#) dialog. Click the down arrow of the *Insert Spaces* option to access this option.

Insert Strings

Inserts a user-defined string in the document at the place defined in the dialog below.

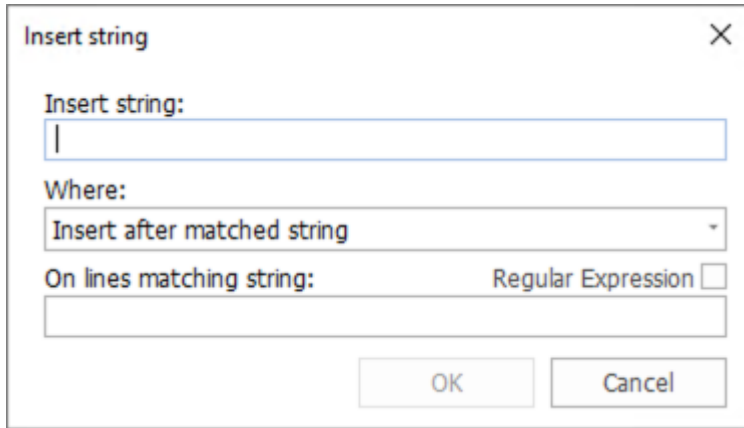

Insert string dialog.

- **Insert string:** Specify the text string to be inserted into the document.

- **Where:** Choose the location in the document where the string will be inserted.
 - **Insert at start of line:** The string will be added at the beginning of the selected line(s).
 - **Insert at end of line:** The string will be appended to the end of the selected line(s).
 - **Insert after block number Replace matched string:** The string will replace the specified block number.
 - **Insert before matched string:** The string will be inserted immediately before the text that matches the specified string.
 - **Insert after matched string:** The string will be placed immediately after the text that matches the specified string.
 - **Insert on new line before matched string:** The string will be inserted on a new line before the line containing the matched string.
 - **Insert on new line after matched string:** The string will be inserted on a new line following the line containing the matched string.

- **On lines matching string:** Define a specific string to target lines where the insertion will occur.

- **Regular Expression:** Use a regular expression pattern to match lines for more complex insertion criteria. See [Regular Expressions](#) for more information.

Removes strings from the NC program according to the specifications entered in the *Remove String* dialog (similar to the *Insert Strings* dialog). Click the down arrow of the *Insert Strings* option to access this option.

DPR **Insert Monitoring Macros**

Inserts monitoring macros in the NC program. Click the down arrow of the *Insert Strings* option to access this option.

When you select this option, the commands and values for program start, feedrate (F), spindle speed (S), and tool change (T) are automatically found in the NC program and inserted into lines starting with **DPRNT** right after the individual command.

The following images show a program before and after adding Monitoring Macros.

```
(AUBENKONTUR FLANSCH 123.50.12)
(AUSFUHRUNG 2)
%
O1010
(ERSTELLUNGSDATUM:02.08.2005 16:15:34)
(PROGRAMMIERER:DK)
N0100 G00 G40 G49 G80 G90
N0110 T10 M6
N0120 S4000 M03
N0130 G00 X0.0 Y0.0
N0140 G00 Z100.0 G43 H12
N0150 G0 X-67.500 Y60.000
N0160 G00 Z2.0
N0170 G1 X-67.500 Y60.000 Z-5.000 F150 M08
N0180 G1 G41 X-67.500 Y55.000 F300
N0190 G3 X-62.500 Y50.000 I-62.500 J55.000
```

CNC program without monitoring macros.

```
(AUBENKONTUR FLANSCH 123.50.12)
(AUSFUHRUNG 2)
%
O1010
POPEN
DPRNT [MACO1010]
(ERSTELLUNGSDATUM:02.08.2005 16:15:34)
(PROGRAMMIERER:DK)
N0100 G00 G40 G49 G80 G90
N0110 T10 M6
DPRNT [MACT10]
N0120 S4000 M03
DPRNT [MACS4000.0]
N0130 G00 X0.0 Y0.0
N0140 G00 Z100.0 G43 H12
N0150 G0 X-67.500 Y60.000
N0160 G00 Z2.0
N0170 G1 X-67.500 Y60.000 Z-5.000 F150 M08
DPRNT [MACF150.0]
N0180 G1 G41 X-67.500 Y55.000 F300
DPRNT [MACF300.0]
N0190 G3 X-62.500 Y50.000 I-62.500 J55.000
```

CNC program with monitoring macros.

The observed values for the macros can be read via the serial interface for further processing.

DPR **Remove Monitoring Macros**

Removes all DPRNT lines that were added using the *Insert Monitoring Macros* function and restores the NC program to its original. Click the down arrow of the *Insert Strings* option to access this option.

Uppercase / Ctrl+U

Changes the case of the text to 'UPPERCASE' - including the comments.

Lowercase / Ctrl+Shift+U

Changes the case of the text to 'lowercase' - including the comments.

Auto Insert Spaces

When this option is activated, a space is automatically inserted before each NC-word if the program is written "in a row" (without spaces).

4.2.3. Transform

This section describes the options in the **Transform** menu. These allow you to quickly adjust feedrate, spindle speed and make mathematical changes to your NC program.

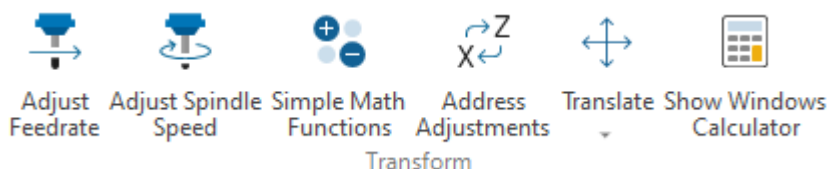

Transform menu.

Menu options

Adjust Feedrate

Use this dialog to adjust the feedrate of the current NC program. To do this, click and drag the slider or enter the new feedrate directly in the field *New feedrate*. Click *OK* to apply the changes or *Cancel* to close the dialog.

Adjust feedrate dialog.

- **New feedrate:** Enter the percentage by which the feedrate should be changed.
- **Decimals:** Enter the number of decimals to the right of the decimal point.
- **Minimum value:** Enter the minimum feedrate (in mm/min).
- **Maximum value:** Enter the maximum feedrate (in mm/min).
- **When equal/greater than:** Only values equal to or greater than the value entered here will be modified.
- **When equal/less than:** Only values equal to or less than the value entered here will be modified.
- **Result to new window:** Check this field if the result of the operation should be shown in a new document.
- **Selection only:** If the *Selection only* option is also checked, only the selection is put into the new document.



Adjust spindle speed

Use this dialog to adjust the spindle speed of the current NC program. To do this, click and drag the slider or enter the new spindle speed directly in the field `_New spindle speed`. Click *OK* to apply the changes or *Cancel* to close the dialog.

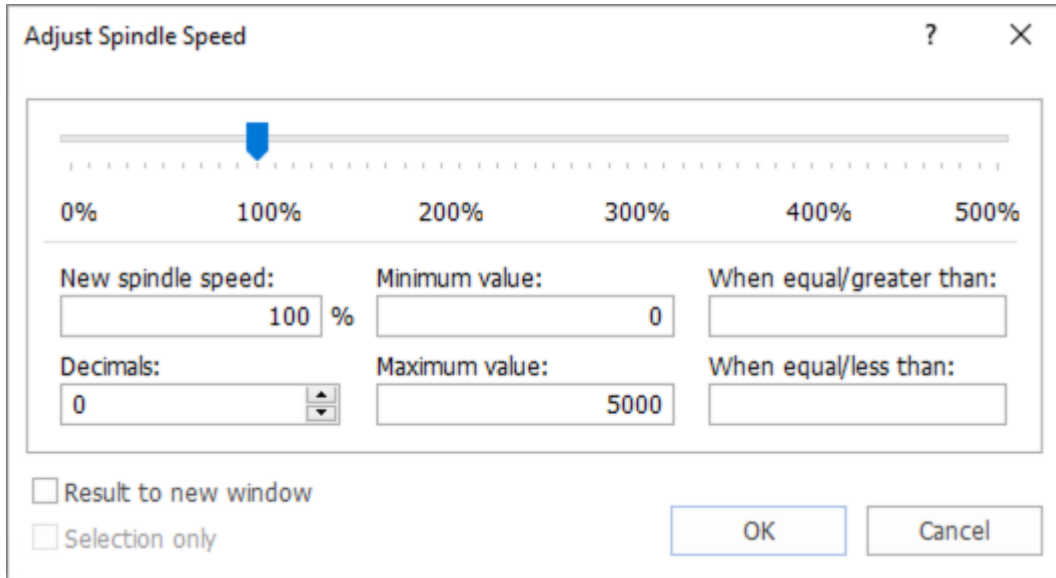

Adjust spindle speed dialog.

- **New spindle speed:** Enter the percentage by which the feedrate should be changed.
- **Decimals:** Enter the number of decimals to the right of the decimal point.
- **Minimum value:** Enter the minimum spindle speed (in rev/min).
- **Maximum value:** Enter the maximum spindle speed (in rev/min).
- **When equal/greater than:** Only values equal to or greater than the value entered here will be modified.
- **When equal/less than:** Only values equal to or less than the value entered here will be modified.
- **Result to new window:** Check this field if the result of the operation should be shown in a new document.
- **Selection only:** If the *Selection only* option is also checked, only the selection is copied to the new document.



Simple math functions

Use this dialog to perform simple mathematical functions on the parameters in the current NC program.

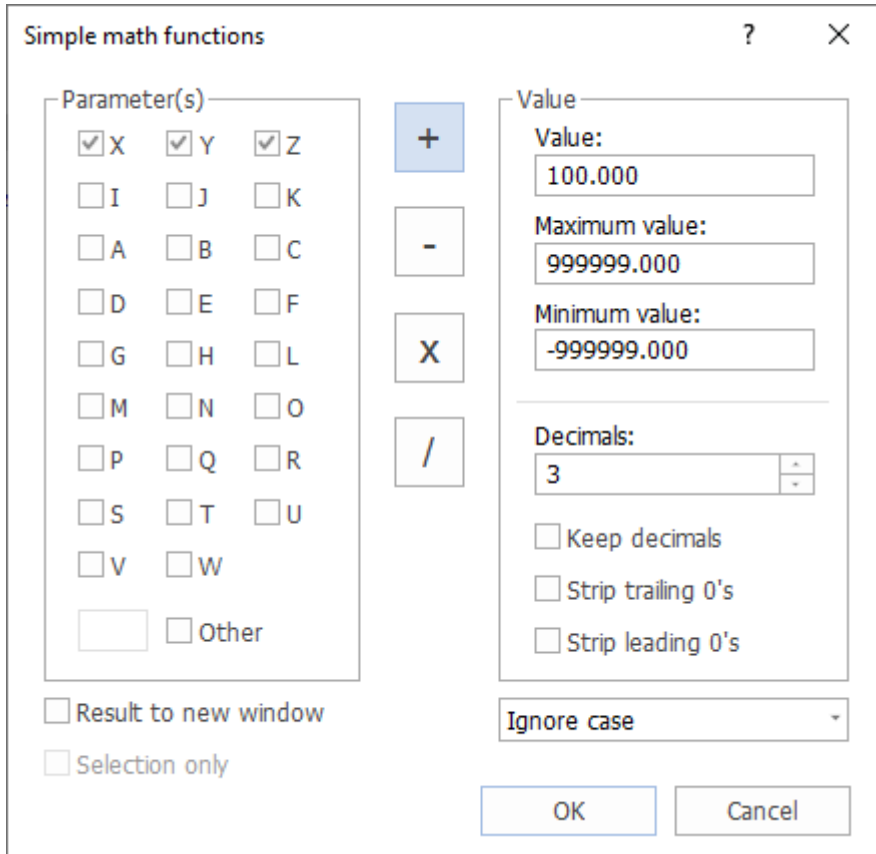

Simple math functions dialog.

- **Parameter(s):** Select the checkboxes of the parameters that should be changed.
- **Other:** Select this option to enter parameters with more than one character. This enables the input field on the left where special characters (Ó, Ö, Ø...) or multi-digit (ABC) parameter names can be entered.
- **Addition (+):** Adds the specified value to all selected parameters.
- **Subtraction (-):** Subtracts the specified value from all selected parameters.
- **Multiplication (X):** Multiplies all selected parameters by the specified value.
- **Division (/):** Divides all selected parameters by the specified value.
- **Value:** Use this field to enter the value that will be inserted in the mathematical function (Addition / Subtraction / Multiplication / Division).
- **Maximum value:** Enter a maximum value. Parameters with values higher than specified here, after performing the mathematical function, will be set to this maximum value.
- **Minimum value:** Enter a minimum value. Parameters with values lower than specified here, after performing the mathematical function, will be set to this minimum value.

- **Decimals:** Enter the number of decimals to the right of the decimal point.
- **Keep decimals:** Select this field to provide the new value with the same number of decimals as the original value.
- **Strip trailing 0's:** Select this field to remove all zeros from the end of the number.
- **Strip leading 0's:** Select this field to remove all zeros from the beginning of the number.
- **Ignore case dropdown:** Select if only parameters in uppercase or lowercase should be changed, or select *Ignore case* to change parameters no matter their case.
- **Result to new window:** Check this field if the result of the operation should be shown in a new document.
- **Selection only:** If the *Selection only* option is also checked, only the selection is copied to the new document.

Translate

Use this dialog to translate the outline. The outline is moved to a position offset by the values entered in the *Translate (X,Y,Z)* fields.

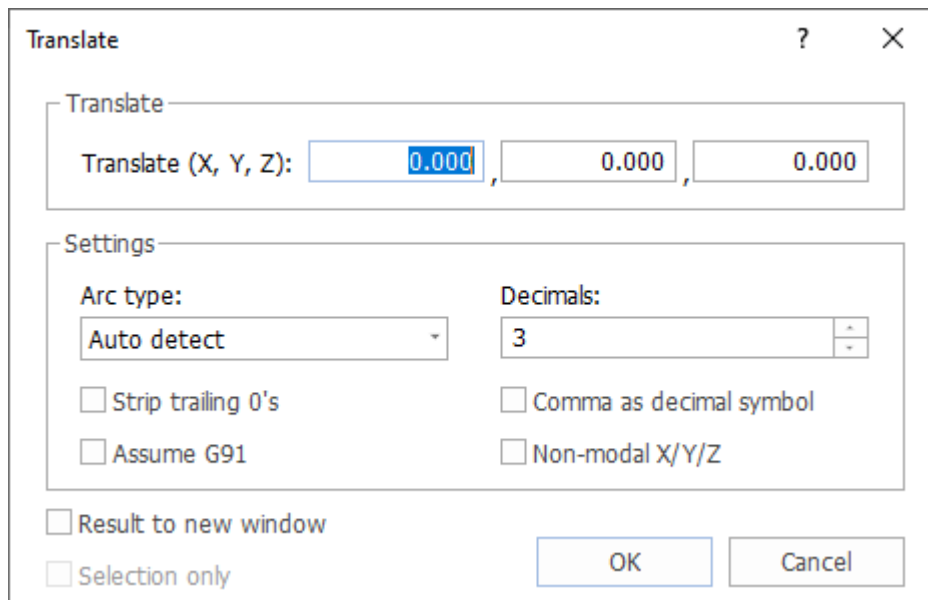

Translate dialog.

- **Translate (X,Y,Z):** Enter the X, Y, and Z values to offset the outline.
- **Arc type:** Specify the arc type by selecting one of the four different types:

- **Auto detect:** Default.
 - **Relative to start:** Relative to the initial coordinates of the contour.
 - **Relative to end:** Relative to the end coordinates of the contour.
 - **Absolute arc center:** Relative to the absolute center of the arc.
- **Strip trailing 0's:** Select this to remove all zeros from the end of the number.
- **Assume G91:** Select this when the control is preset for relative coordinates (G91).
- **Decimals:** Enter the number of decimals to the right of the decimal point.
- **Comma as decimal symbol:** Select this to use a comma as decimal separator.
- **Non-modal X/Y/Z:** Select this to use non-modal X/Y/Z values.
- **Result to new window:** Check this field if the result of the operation should be shown in a new document.
- **Selection only:** If the *Selection only* option is also checked, only the selection is copied to the new document.

Rotate

Use this dialog to rotate the outline around a specified point and with a specified angle. Click *OK* to apply the changes or *Cancel* to close the dialog with no changes.

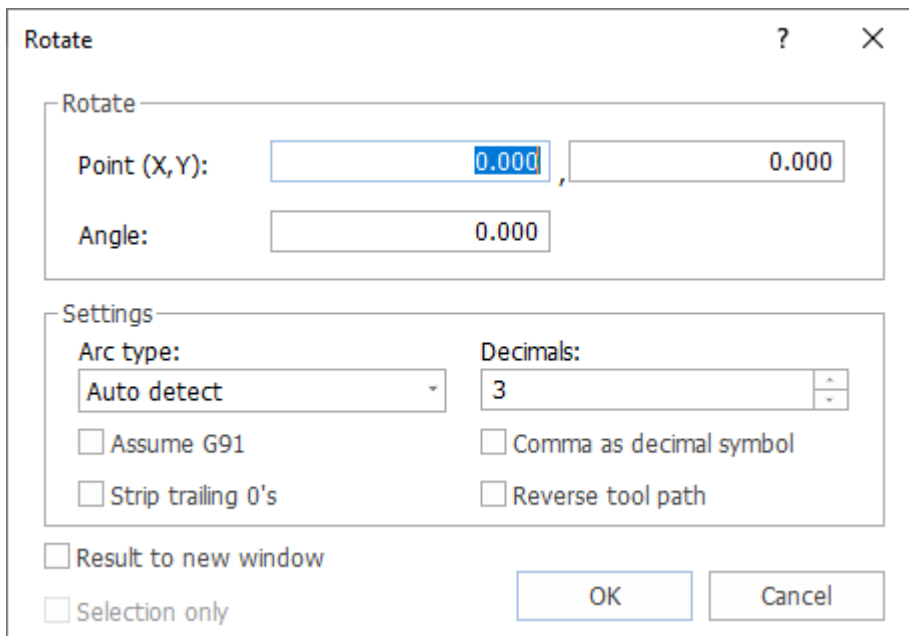

Rotate dialog.

- **Point (X,Y):** Enter the coordinates of the center of the rotation in these fields.
 - **Angle:** Enter the angle of rotation by degrees in this field.
 - **Arc type:** Here you can specify the arc type by selecting one of the four different types:
 - **Auto detect:** Default.
 - **Relative to start:** Relative to the initial coordinates of the contour.
 - **Relative to end:** Relative to the end coordinates of the contour.
 - **Absolute arc center:** Relative to the absolute center of the arc.
 - **Assume G91:** Select this when the control is preset for relative coordinates (G91).
 - **Strip trailing 0's:** Select this to remove all zeros from the end of the number.
 - **Decimals:** Enter into this field the number of decimals to the right of the decimal point.
 - **Comma as decimal symbol:** Select this to use comma as decimal separator.
 - **Reverse tool path:** Select this to reverse the trajectory of the tool path.
 - **Result to new window:** Check this field if the result of the operation should be shown in a new document.
 - **Selection only:** If the *Selection only* option is also checked, only the selection is copied to the new document.
-

Mirror

Use this dialog to mirror the outline around a specified line. Click *OK* to apply the changes or *Cancel* to close the dialog with no changes.

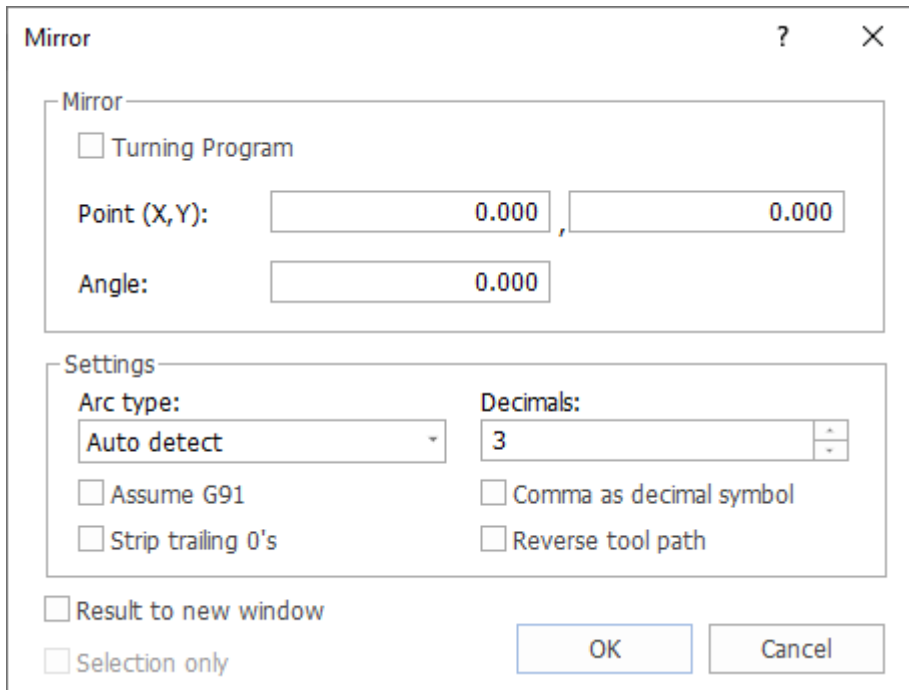

Mirror dialog.

- **Turning Program:** Select this option for turning operations. This will disable the *Point* and *Angle* fields below (the user-defined mirror axis).
- **Point (X,Y):** Enter the coordinates of the point of the mirror axis.
- **Angle:** Enter the angle of rotation by degrees of the mirror axis.
- **Arc type:** Specify the arc type by selecting one of the four different types:
 - **Auto detect:** Default.
 - **Relative to start:** Relative to the initial coordinates of the contour.
 - **Relative to end:** Relative to the end coordinates of the contour.
 - **Absolute arc center:** Relative to the absolute center of the arc.
- **Assume G91:** Select this when the control is preset for relative coordinates (G91).
- **Strip trailing 0's:** Select this to remove all zeros from the end of the number.
- **Decimals:** Enter the number of decimals to the right of the decimal point.
- **Comma as decimal symbol:** Select this to use comma as decimal separator.
- **Reverse tool path:** Select this to reverse the trajectory of the tool path.
- **Result to new window:** Check this field if the result of the operation should be shown in a new document.

- **Selection only:** If the *Selection only* option is also checked, only the selection is copied to the new document.



Tool compensation

Use this dialog to configure toolpath compensation (offset) for the current program. From the programmed workpiece contour to the left (G41), or to the right (G42), based on the direction of feed, in order to compensate different tool sizes.

Offset/Tool compensation dialog.

- **Offset:** Enter the offset value into this field.
- **Offset Left (G41):** Enable compensation of the milling path, offset left (G41).
- **Offset Right (G42):** Enable compensation of the milling path, offset right (G42).
- **Arc type:** Specify the arc type by selecting one of the four different types:
 - **Auto detect:** Default.
 - **Relative to start:** Relative to the initial coordinates of the contour.
 - **Relative to end:** Relative to the end coordinates of the contour.
 - **Absolute arc center:** Relative to the absolute center of the arc.
- **Strip trailing 0's:** Select this to remove all zeros from the end of the number.
- **Assume G91:** Select this when the control is preset for relative coordinates (G91).

- **Decimals:** Enter the number of decimals to the right of the decimal point.
- **Comma as decimal symbol:** Select this to use comma as decimal separator.
- **Non-modal X/Y/Z:** Select this to use non-modal X/Y/Z values.
- **Result to new window:** Check this field if the result of the operation should be shown in a new document.
- **Selection only:** If the *Selection only* option is also checked, only the selection is copied to the new document.



Heidenhain / ISO Converter

Use this option to convert Heidenhain CNC programs to ISO programs, or ISO programs to Heidenhain CNC programs.



Convert NC code

Use this option to convert from one NC format to another. You will need a converter file, also known as a Post Processor, for the target format.

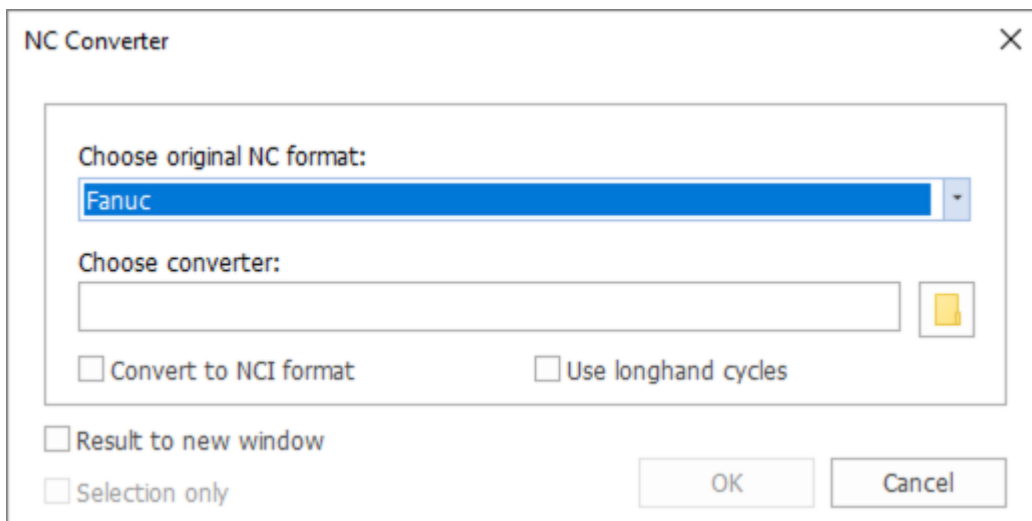

NC Converter dialog

- **Choose original NC format:** Select the NC format to convert from.
- **Choose converter:** Select the converter/post processor file (.conv) for the NC format to convert to. CIMCO Edit includes some converters located in the \Converters folder in the program folder.

- **Convert to NCI format:** Select this to convert the NC code to NCI, a generic or intermediate format that represents toolpaths before they are converted into the final NC code by a post processor.
- **Use longhand cycles:** Select this to output each movement or cycle as individual lines of code, rather than using shorthand or canned cycles.
- **Result to new window:** Check this field if the result of the operation should be shown in a new document.
- **Selection only:** If the *Selection only* option is also checked, only the selection is copied to the new document.



Show Windows Calculator

Click this option to open the Windows® calculator.

4.2.4. Info

This section describes the options under the **Info** menu. These can be used to calculate toolpath statistics and generate tool lists.

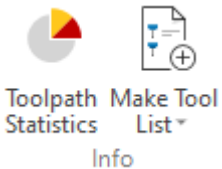

Info menu.

Menu options



Toolpath Statistics

Use this dialog to see detailed information about the CNC program's toolpaths. The range of X,Y,Z, machining time, tool change time, toolpath length, etc. Data can be exported or visualized in a graph.

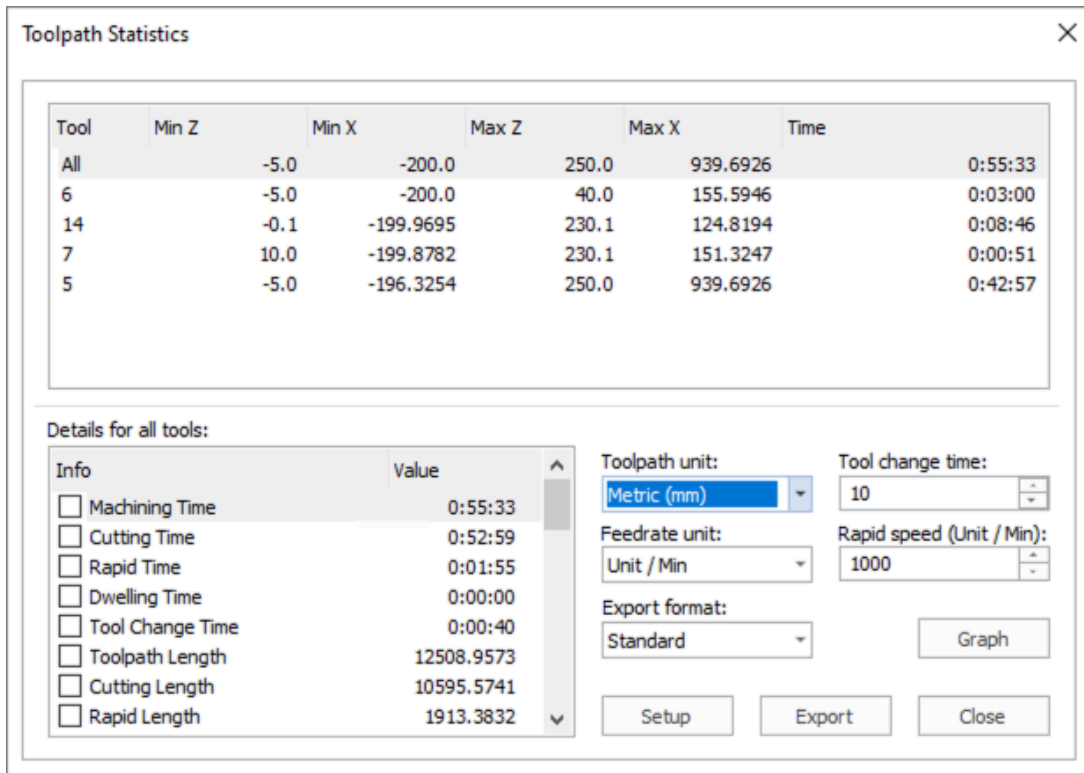

Toolpath Statistics dialog.

The top part of the dialog shows information about each tool in the current NC program such as the min/max XYZ positions and total time. When changing units, the *Tool change time*, or *Rapid speed* (in the lower part of the screen), this is immediately reflected in the data.

In the lower part of the dialog, you can set units, *Tool change time*, *Rapid speed* and configure what data to export. Make sure to select *All* or a specific tool in the list at the top.

- **Details for all tools:** Select the toolpath data you wish to export.
- **Toolpath unit:** Set Toolpath unit to either *Metric (mm)* or *Imperial (Inches)*.
- **Feedrate unit:** Set Feedrate unit to either *Unit/Min* or *Unit/Rev*.
 - **Unit/Min:** This option sets the feedrate in units per minute, which is a common way to measure the speed at which the tool moves across the material surface.
 - **Unit/Rev:** This option sets the feedrate in units per revolution, typically used in turning operations where the speed is determined by the number of units the tool moves per each rotation of the workpiece.
- **Tool change time:** Enter the average time taken for a tool change to accurately calculate total machining time.
- **Rapid speed (Unit/Min):** Enter the machine's rapid traverse rate to estimate non-cutting movement time.

- **Export format:** Select the export format: *Standard* or *CSV*. When clicking the *Export* button, a new document is created with the exported data.
- **Graph:** Open the *Toolpath Graphs* dialog. See below.
- **Setup:** Click this button to open the [Backplot](#) dialog in the *Editor Setup*.
- **Export:** Click this button to export the data. A new document will be created with the exported data.



Make Tool List

Create a tool list based on the current NC program. The tool list is created in a new document.



Combined Tool List

Create a combined tool list based on two or more open NC programs. The tool list is created in a new document.

Configure Tool List

Configure how the tool list is generated. Please refer to [Tool List](#) section in the *Editor Setup* for more details.

Toolpath Graphs

The *Toolpath Graphs* dialog is a useful tool that can help you catch mistakes and irregularities that might not be obvious when looking at the code alone.

The dialog shows a graph with a line for each axis. Horizontally the graph shows the movement over time and vertically, it shows the position of the cutting tool. Each line has its own color, making them easy to tell apart.

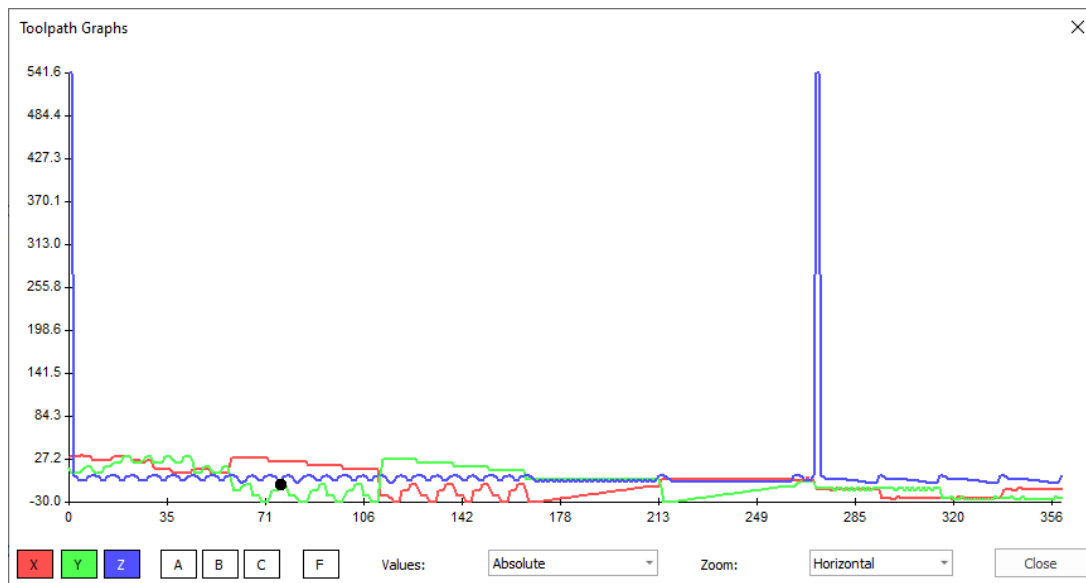

Axes (X,Y,Z,A,B,C)

Use these buttons to toggle the visibility of axes in the graph.

Feedrate (F)

Use this button to toggle the visibility of Feedrate in the graph.

Values

Use this dropdown to select how to display tool position values (vertical).

- **Absolute:** displays the absolute position of the tool.
- **Delta:** displays the tool position relative to its last position.

Zoom

Use this dropdown to select the type of zoom. You can zoom in and out on the graph with the mouse scroll wheel.

- **Horizontal:** only zoom the graph horizontally
- **Vertical:** only zoom the graph vertically
- **2-Dimensional:** zoom the graph both horizontally and vertically

Close

Click this button to close the dialog.

4.3. NC-Assistant

This section describes the options in the **NC-Assistant** tab.

The *NC-Assistant* in CIMCO Edit is a collective term for a range of options that help you streamline the coding process, making it faster and less prone to errors. Central to these options are the macro tools, which include an extensive array of predefined macros as well as the option for users to create their own.

These macros are key in allowing CIMCO Edit to identify specific lines or blocks within your code, facilitating swift updates through a dynamic interface. This interface, which aids in modifying parameter values, is conveniently accessible via the [NC-Assistant sidebar](#). Here, users can also find a comprehensive list of macros, ensuring that these powerful tools are readily available for efficient coding.

4.3.1. NC-Assistant

This section describes the options in the *NC-Assistant* menu which allow you to insert, modify and find macros in your code.

The *NC-Assistant* menu is closely tied to the [Macros](#) menu beside it and the options *Insert Macro* and *Find Macro* both use the macro that is selected in the *Macro Name* dropdown in the [Macros](#) menu.

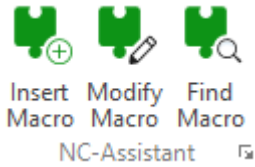

NC Assistant menu.

Menu options

Insert Macro

Inserts the macro that is selected in the *Macro Name* dropdown in the [Macros](#) menu.

A macro can also be inserted by double-clicking its name in the NC-Assistant sidebar or selecting it and clicking the *Add* button.

When inserting a macro, you need to enter two types of parameters:

1. The required parameters
2. The optional parameters (marked with *).

The parameter fields in the *Insert* dialog will change depending on the macro being inserted. Enter the parameters and click OK to insert the macro.

Insert Macro dialog.



Modify Macro

Modify the macro at the cursor position.

To modify the values in an already inserted macro, position the mouse cursor on the macro-code (notice the *Modify Macro* icon in the Ribbon bar becomes active) and click the *Modify Macro* option.

The *Modify* dialog will appear in which you can update the macro parameter values. Click *OK* to apply the changes.

If default values have been defined for a macro, clicking the *Default* button will revert the values to their original, default values.

Please see the [NC-Assistant Sidebar](#) for an alternative to this option.

Modify: G1 Linear Interpolation Motion
✕

Parameters for 'G1 Linear Interpolation Motion'

* X-Axis motion command

* Y-Axis motion command

* Z-Axis motion command

* A-Axis motion command

* B-Axis motion command

* C-Axis motion command

* Feedrate

* Radius of the arc

* Chamfer distance

* = Optional parameter

The Modify Macro dialog.



Find Macro

Search for the macro that is selected in the *Macro Name* dropdown in the [Macros](#) menu.

You can search for a macro in an NC program in two ways:

1. In the field *Cycles/Macros*, select the macro to search for and click the button *Find Macro*.
2. Select the macro to search for from the dropdown list and click on the icon *Find Macro*.

If you receive the message: `_Cannot find the macro ...`, it is because the desired macro was not specified as a macro. This can be the case if the NC text has been copied or created manually.

Macro Setup

Click this to enter the [Macro Setup](#) dialog.

4.3.2. Macros

This section describes the options in the *Macros* menu which allow you to select *File Type*, *Macro Group* and *Macro Name*.

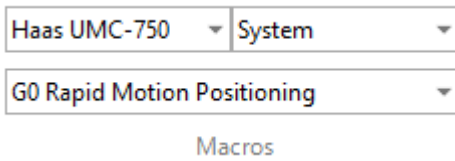

Macros menu.

Menu options

File Type

Shows the current file type. Click this to select a different file type from the dropdown list. This dropdown does the same as the dropdown in the [File Type](#) menu in the Editor tab.

Macro Group

Shows the current *Macro Group*. Use this dropdown to select a different *Macro Group*. *Macro Groups* can be configured in the [Macro Setup](#) dialog.

Macro Name

Shows the currently selected macro. This is the macro that will be used when using the [Insert Macro](#) and [Find Macro](#) options in the *NC-Assistant* menu.

Click this dropdown to select a different macro.

4.3.3. Info

This section describes the options in the *Info* menu which allow you to toggle the visibility of the NC-Assistant sidebar and the NC code balloons (tooltips).

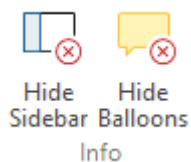

Info menu.

Menu options



Click this option to show or hide the [NC-Assistant sidebar](#).



Hide Balloons

When hovering the mouse over an NC code, a yellow balloon (tooltip) will show with an easy-to-read overview of the code parameters.

Click this option to show or hide the NC-Assistant balloons (tooltips).

4.3.4. Setup

This section describes the options in the *Setup* menu.



Macro Setup menu.

Menu options



Record Macro

To create a macro from a specific or frequently recurring NC block, select the block in your NC program and then click on the *Record Macro* option.

The dialog *Add Macro* will appear in which you must name the new macro. Once you click the *OK* button to continue, the *Macro Setup* dialog will open for further configuration of the new macro.

Please refer to the [Macro Setup](#) dialog for further information.



Macro Setup

Opens the *Macro setup* dialog where you can configure, add, and modify macros for different file types. Please refer to the [Macro Setup](#) dialog for further information.

4.3.4.1. Macro Setup Dialog

The *Macro Setup* dialog allows you to configure, add, and modify macros for different file types.

To import or backup your macros, locate the .MAC files that store the Macro configurations. These files can be found in the following directory: %appdata%\CIMCO 2026\CIMCOEdit\Types\.

The dialog *Macro Setup* is divided into three functional areas that are described in details in the following sections.

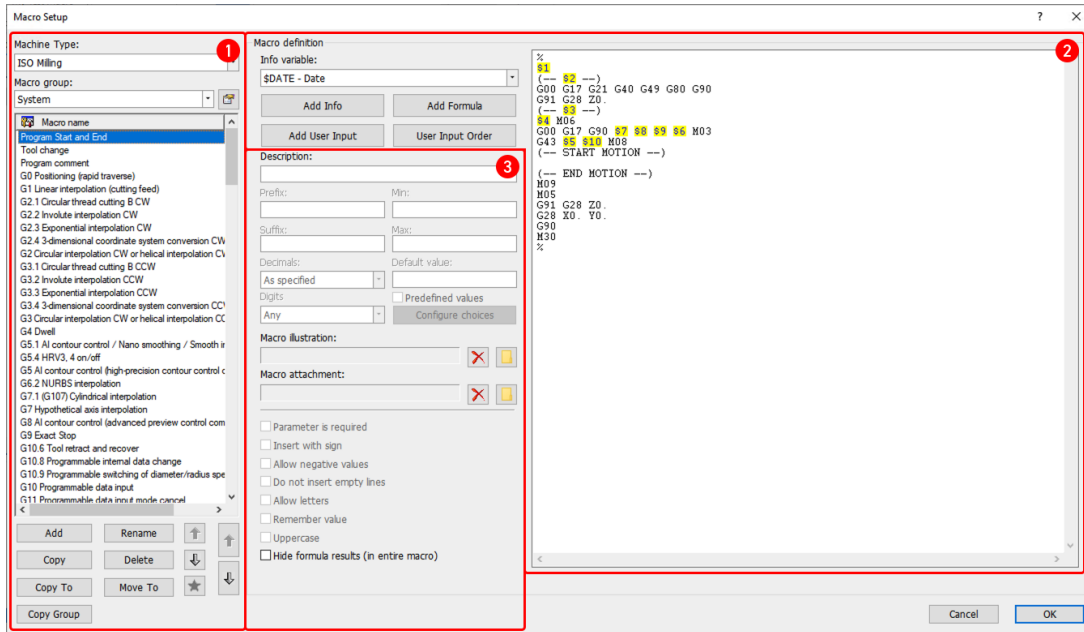

Macro Setup dialog.

Area 1: List of macros

Machine Type

This drop-down menu provides a list of defined machine types you can select from (e.g. ISO Milling, ISO Turning, Heidenhain, etc.).

When the *Machine Type* is changed, the *Macro group* dropdown is updated with the available groups for the selected type.

Macro group

This drop-down menu provides a list of defined macro groups.

To create, rename or delete a macro group, click on the **Edit Macro Groups** icon  at the right on this field.

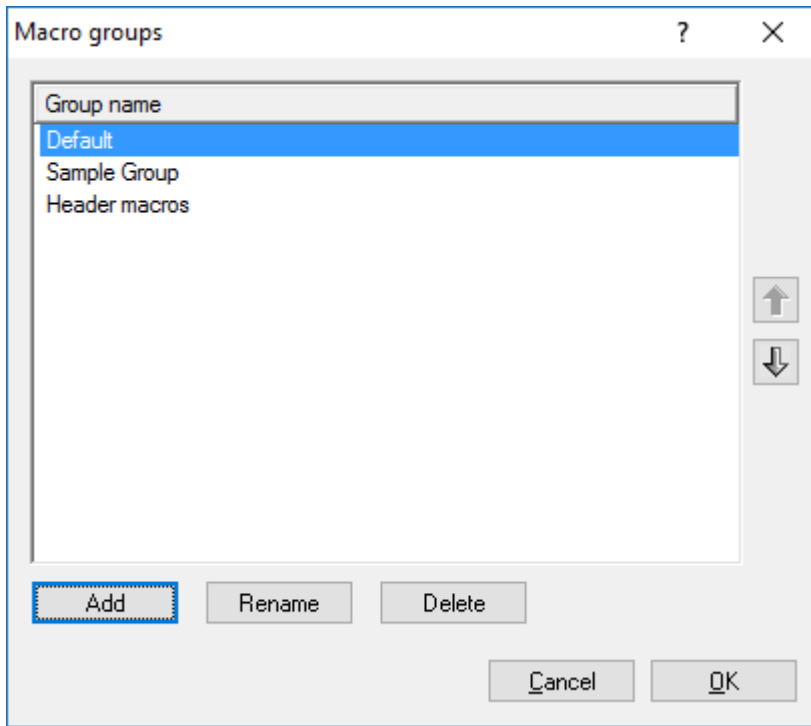

Edit Macro Groups dialog.

 **Macro name**

Here you can see all available macros for the selected machine type and macro group.

Add

Click this button to open the dialog *Add macro*. Enter the name of the new macro and click **OK**. The new macro is added right after the selected macro in the *Macro name* list.

Rename

Click this button to rename the selected macro.

Copy

Click this button to make a copy of the selected macro.

You can make a few changes in the name and the contents of the macro to create a similar macro and save it.

Delete

Click this button to delete the selected macro.

It will display a confirmation message asking if you really want to delete the selected macro. If you answer

Yes, the macro name and its contents will be deleted.

Copy To

Click this button to copy the selected macro to a different configuration.

The Copy Macros dialog will allow you to copy several macros at a time (check boxes at the left of the macro name) to the specified target Machine Type and Macro Group.

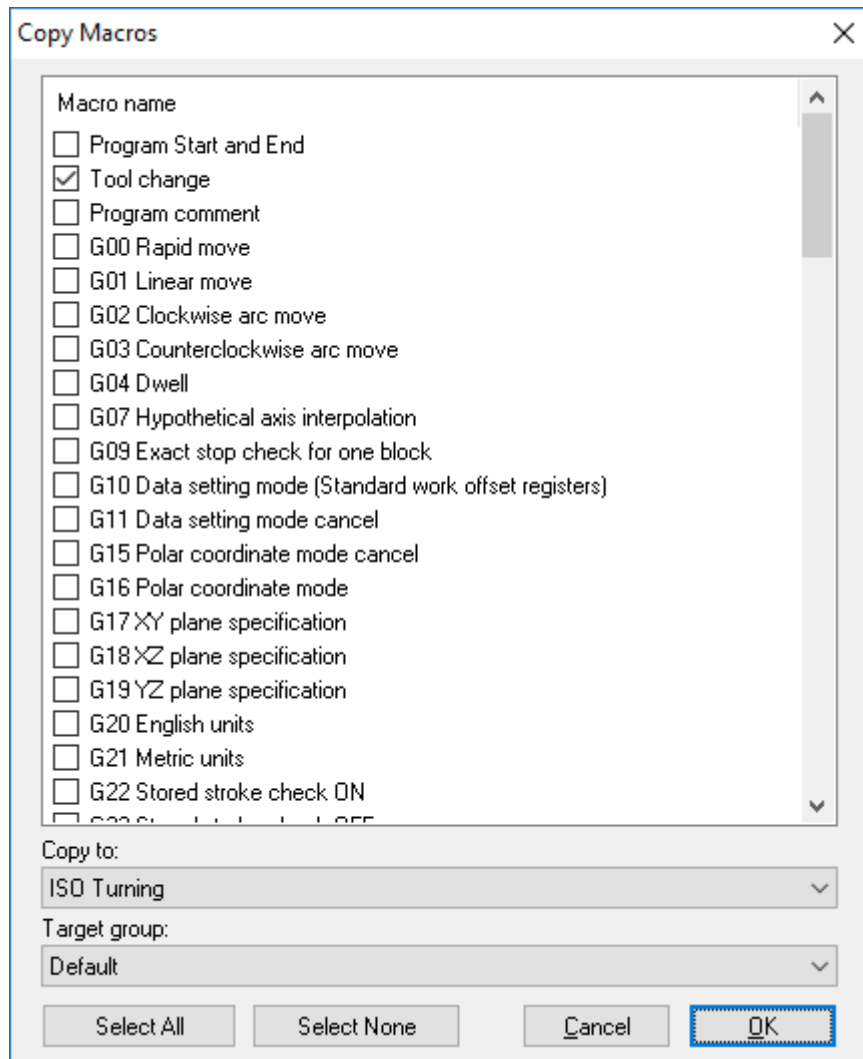

Copy Macros dialog.

Move To

Click this button to move the selected macro to a different configuration.

The functionality is similar to the **Copy To** button, but the selected macros are deleted from the original Machine Type and Macro Group.

Copy Group

Click this button to copy one or more *Macro Groups* from one File Type to another. This action opens the *Copy Macro Groups* dialog.

Within the dialog:

- On the left side, select the File Type and the Macro Groups you wish to copy.
- On the right side, choose the File Types to which you want to copy the selected groups.

In the *Duplicate Copy Behavior* dropdown, define the action to take if an identical *Macro Group* already exists in the target *File Type*. Your options are:

- **Skip duplicates:** The copy process will bypass any group that already exists in the target File Type.
- **Overwrite duplicates:** The process will replace the existing group in the target File Type with the one being copied.
- **Abort copy of duplicate:** Abort the copy process.

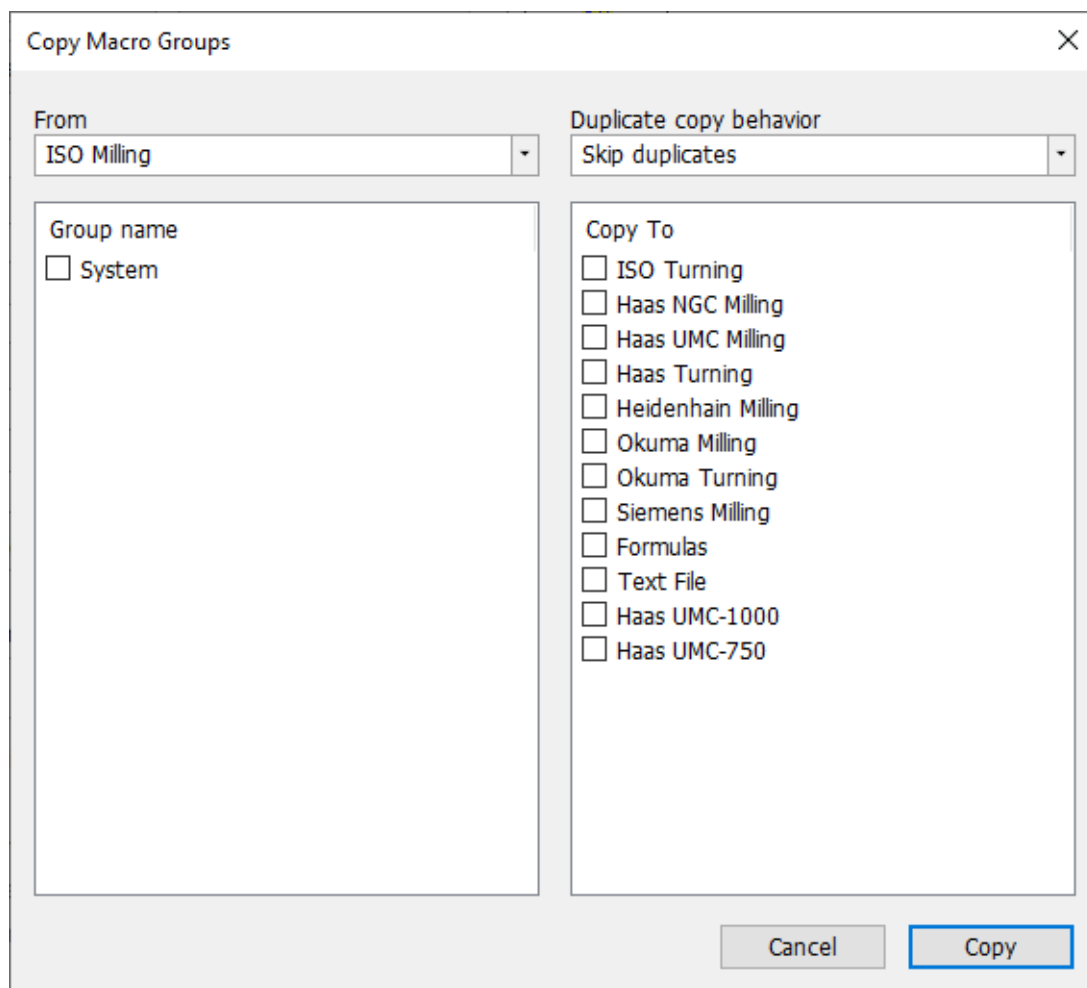

Copy Macro Groups dialog



Up / Down arrows

Use these buttons to move the selected macro up or down the list.

Use the larger arrow buttons to move the selected macro 10 places up or down the list.



Favorite

Use this button to favorite or un-favorite a macro.

When a macro is favored (star is glowing) it will show in the *Favorites* group. The favorite macro will show group name and macro name in the format:

{group}->{macro}.

Pressing the **Favorite** button when the favorite already exists will remove the favorite.

Area 2: Macro definition



Macro definition field

In the *Macro definition* section of the dialog, use the large text entry field (*Macro definition field*), on the right-hand side of the dialog, to enter the contents of the macro including text, variables and formulas.

The following options are available:

- **User (input) variables:** User variables are specified with a '\$' character followed by a number in ascending order (\$1, \$2, \$3, ect.). When selected, User variables can be configured in the fields under *Description*. User Variables can either be written directly or inserted using the button *Add User Input*. You can use the same variable multiple times in a macro.
- **System variables:** System variables are specified with a '\$' followed by an uppercase variable name. System variables insert data/info from the system and cannot be modified. You can use the *Info variable* dropdown to see the available System variables and insert using the button *Add info*.
- **Formulas:** Formulas are specified with a '@' character followed by a number and an opening and closing bracket where the formula can be entered. Please refer to [Formulas in Macros](#) for further information.
- **Block numbers:** To add a block number to a line, specify a '#' at the beginning of the line. When the macro is inserted, # will be replaced with the correct block number value.
- **# character in front:** If you need to output a '#' as the first character in a string (which will be interpreted as a Block number by default), you can do this by entering '##' instead. This can be useful for Fanuc Macro B variables.

- **Character after variable:** If you need to insert a character right after a variable, you must insert a '|' (vertical bar) after the variable such as \$2|100.
- **Start on new line:** If a macro *must* start on a new line, when inserted, add a blank line first in the macro definition field.

Please refer to the predefined macros in CIMCO Edit, such as *Program Start and End* to see examples of how macros can be configured.

Info variable

Use this dropdown menu to see a list of available *System variables* such as date, time, date and time, filename, etc. When a variable is selected from the list, insert it by clicking the button *Add Info*.

Add Info

Click this button to insert a System variable (selected in the *Info variable* dropdown list).

Add Formula

Click this button to insert a new formula.

Formulas are specified with a '@' character followed by a number and an opening and closing bracket where the formula can be entered.

Example: @3{sqrt(\$1*\$1 + \$2*\$2)}

Please refer to [Formulas in Macros](#) for further information.

Add User Input

Click this button to insert a new User variable such as \$1, \$2, \$3, etc.

User Input Order

Click this button to arrange the order in which User variables are presented in the *Insert* dialog when adding the macro. This does not change the order of the variables when the macro is inserted in the NC program.

Clicking this button shows the following dialog. Use the up/down arrows to change the order of variables.

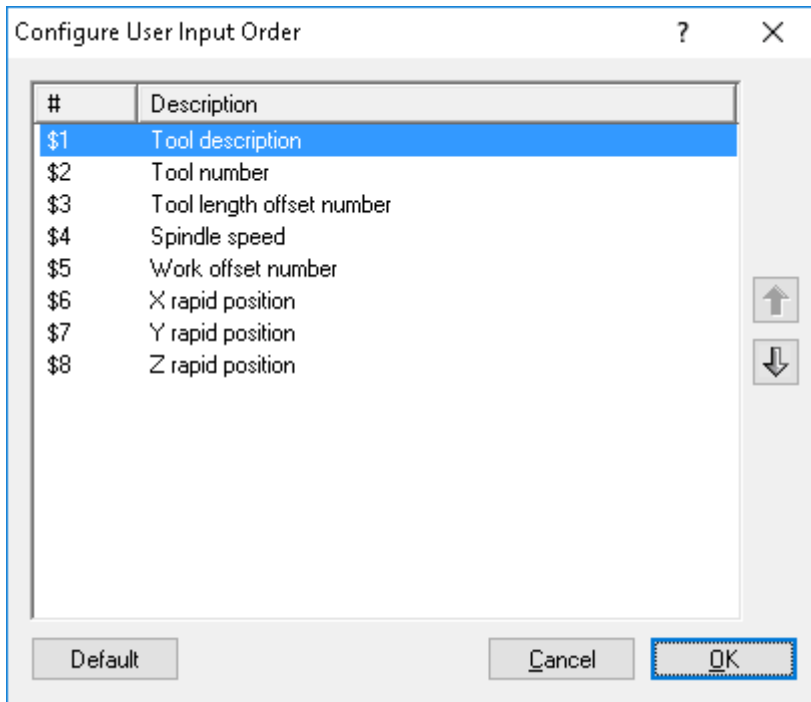

User Input Order dialog.

Area 3: Parameter configuration

Select or click a variable or formula in the *Macro definition field* to configure it using the fields and options in Area 3.

Description

Use this field to add a description of the selected parameter.

When you insert the macro into the CNC program by clicking the icon , the *Insert* dialog will appear to let you enter all macro parameters. The description is shown next to the parameter field.

Macro parameter input fields (example).

Prefix

Use this field to specify a prefix string for the selected parameter, e.g. T for tool or S for spindle speed. This string or character will be added right before the value specified in the *Insert* dialog.

Suffix

Use this field to specify a suffix string for the selected parameter. Works the same way as *Prefix* but will be added right after the value specified in the *Insert* dialog.

Decimals

Use this dropdown to select the number of decimal digits.

- **As specified:** The number of decimals in the input and output will remain the same. Entering 10 will output 10. Entering 10.1 will output 10.1.
- **Any:** Will output at least 1 decimal. Entering 10 or 10. will both output as 10.0. Entering 10.123 will output as 10.123.
- **0 - 5:** Will output the number of decimals selected (0-5). If 3 is selected, entering 10 will output 10.000 (3 decimals). Entering 10.12 will output 10.120.

Always check the results of the formulas carefully to make sure you are getting the correct value and format.

Digits

Use this field to specify the number of digits. E.g. when inserting an O-number with 4 digits, the result becomes 'O0007'.

Min

Use this field to specify a minimum value for the selected parameter. If you enter a value lower than the *Min* value, you will immediately be prompted for correction.

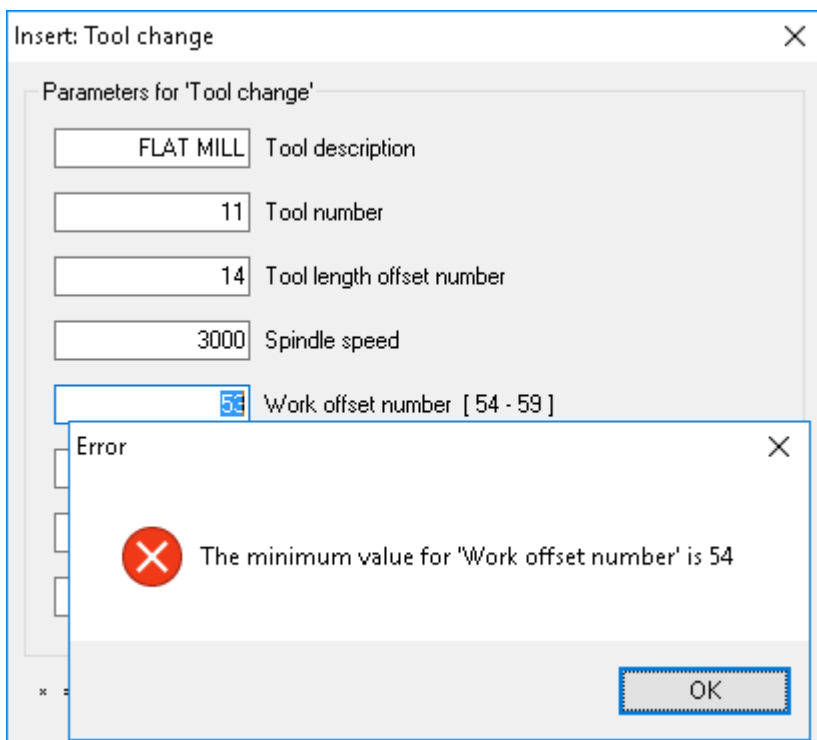

Error message for value lower than *Min*.

Max

Use this field to specify a maximum value for the selected parameter. If you enter a value higher than the *Max* value, you will immediately be prompted for correction.

Default value

Use this field to specify a default value for the selected parameter.

Predefined values

Select this option if this macro parameter must be selected from a list of predefined values.

Click the button **Configure choices** to enter the specific values the user can choose from when inserting this macro parameter.

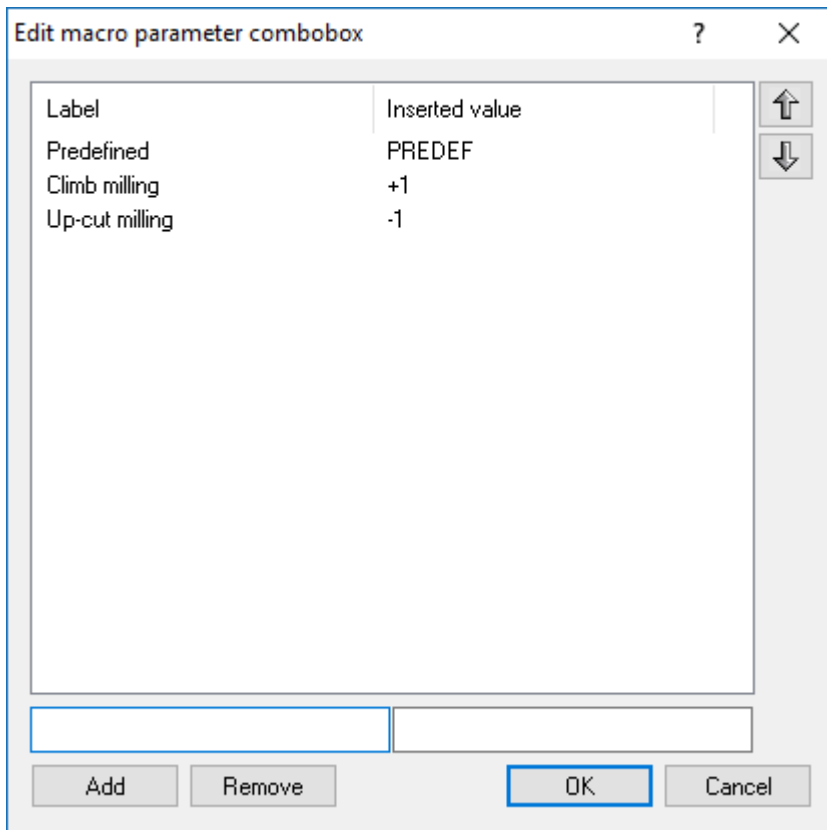

Predefined values setup dialog.

This dialog shows the list of values that will be available to select for the user when inserting the macro.



- **Label:** the text that will be displayed in the dropdown for the user to select.
- **Inserted value:** the value which will be inserted into the NC code output of the macro.

If *Label* is left blank, it will automatically be filled with the value. Double-click a Label-value pair to edit it. The pairs will appear in the dropdown in the same order as in this dialog with the top one selected as default.

Macro illustration / Parameter illustration



Use this field to specify a general macro image or a parameter image that will be shown in the *Insert* dialog. Click on a variable to specify a Parameter illustration in this field or click anywhere outside to add a general macro image.

- **Parameter illustration** will be shown when the input field for the parameter is active.
- **Macro illustration** will be shown when the input box for a parameter, which does not have a Parameter illustration defined, is active.

Click the **Select Picture** button  to select the desired picture for the macro/parameter, and the **No Picture** button  to remove the picture.

Macro attachment

Adding an attachment to a macro will show a button in the *Insert* dialog that, when clicked, will open the attachment. This can be used to associate a detailed help file to a macro.

Click the **Select attachment** button  to select an attachment for the macro, and the **Clear attachment** button  to remove the file.

Area 3: Parameter monitoring / Additional options

Use the checkboxes to enable or disable additional options.

The additional options must be selected carefully, as they affect the final result.

Parameter is required

Check this field if the user is required to specify a value for the selected parameter.

If you do not check this box, the sign * will appear in the parameter input field, indicating that this parameter is *optional*. In this case, you do not need to enter a value in the field. If you do it anyway, you will change the (modal) value for this NC code.

Optional Parameters can for example be found at the 3 axes (X, Y, Z) of linear move (G01).

Insert with sign

Check this field if the parameter value should be inserted with a sign.

Example: The value 123.4 will be inserted as +123.4.

Allow negative values

Check this field to allow negative values for the current parameter.

If you leave this field unchecked, only positive values will be accepted.

If you (accidentally) enter a negative value into the macro fields, the (-) sign will be ignored. The entered value will be considered as the absolute value of the parameter and will output positive NC codes in the CNC program.

Do not insert empty lines

Check this field if no blank line should be inserted when this parameter is not specified.

Allow letters

Check this field to allow the user to enter a text string.

According to ISO Convention, texts in the CNC program must be written in parentheses so they can be read on CNC machines. To prevent forgetting the brackets, these are generated automatically in CIMCO Edit 2026 when the field *Allow letters* is checked. Besides, the input fields *Min*, *Max*, *Decimals*, *Digits* and the box *Allow negative values* are grayed out.

Example: The parameter \$2 in the macro *Program Start and End* can include programmer initials, text strings, and special characters in parentheses.

Remember value

Check this field if the last value entered for this parameter should be used the next time the macro is called.

Example: Let's assume you need to drill a blind hole into a special steel with three depths Z10, Z16 and Z20 at a defined location (X,Y). To achieve this, use the macro 'G81 Drilling cycle' and check the box *Remember value* for the parameters \$1, \$3, and \$4. This way, those parameters will be automatically filled out with the previous settings for the blind hole machining. As we want to drill at different depths, we do not select *Remember value* for the parameter \$2, which is the modal Z value of the operation. Since *Remember value* is not activated, the field \$2 will be marked with an * and is initially empty.

If the drilling program was previously run and you now call the macro 'G81 Drilling cycle' by clicking the icon



, you just need to enter the first desired Z-value 10 into the field *Z coordinate (absolute)* and click on OK. Repeat the macro command with the Z-values 16 and 20, all other fields will be automatically filled out with the previously used values. Then you will have your blind hole.

Insert: G81 Drilling cycle

Parameters for 'G81 Drilling cycle'

98 Rapid retract (98=initial level, 99=R level) [98 - 99]

* 20 Z coordinate (absolute)

4 Retract level (absolute)

150 Feedrate

* = Optional parameter

Default Cancel OK

Remember value in macro G81.

Uppercase

If the option *Allow letters* is enabled and you want to write with capital letters, check this field to make the user input uppercase.

You must check this box if you want to use both lower and uppercase in the text.

Hide formula results (in entire macro)

When this field is checked, the results of NC-Assistant macro formulas are hidden.

Please refer to [Formulas in Macros](#) for more information.

4.3.4.2. Formulas in Macros

CIMCO Edit can calculate and output values based upon a user input value. This has many uses and increases the power of the macro function.

CIMCO Edit 2026 includes predefined (sample) formulas that demonstrate the application of formulas within macros. To explore these, launch CIMCO Edit 2026 and choose *Formulas* from the *File Type* dropdown menu.

The sample file itself is located in the CIMCO Edit directory under \Samples\Formulas\formulas.MAC.

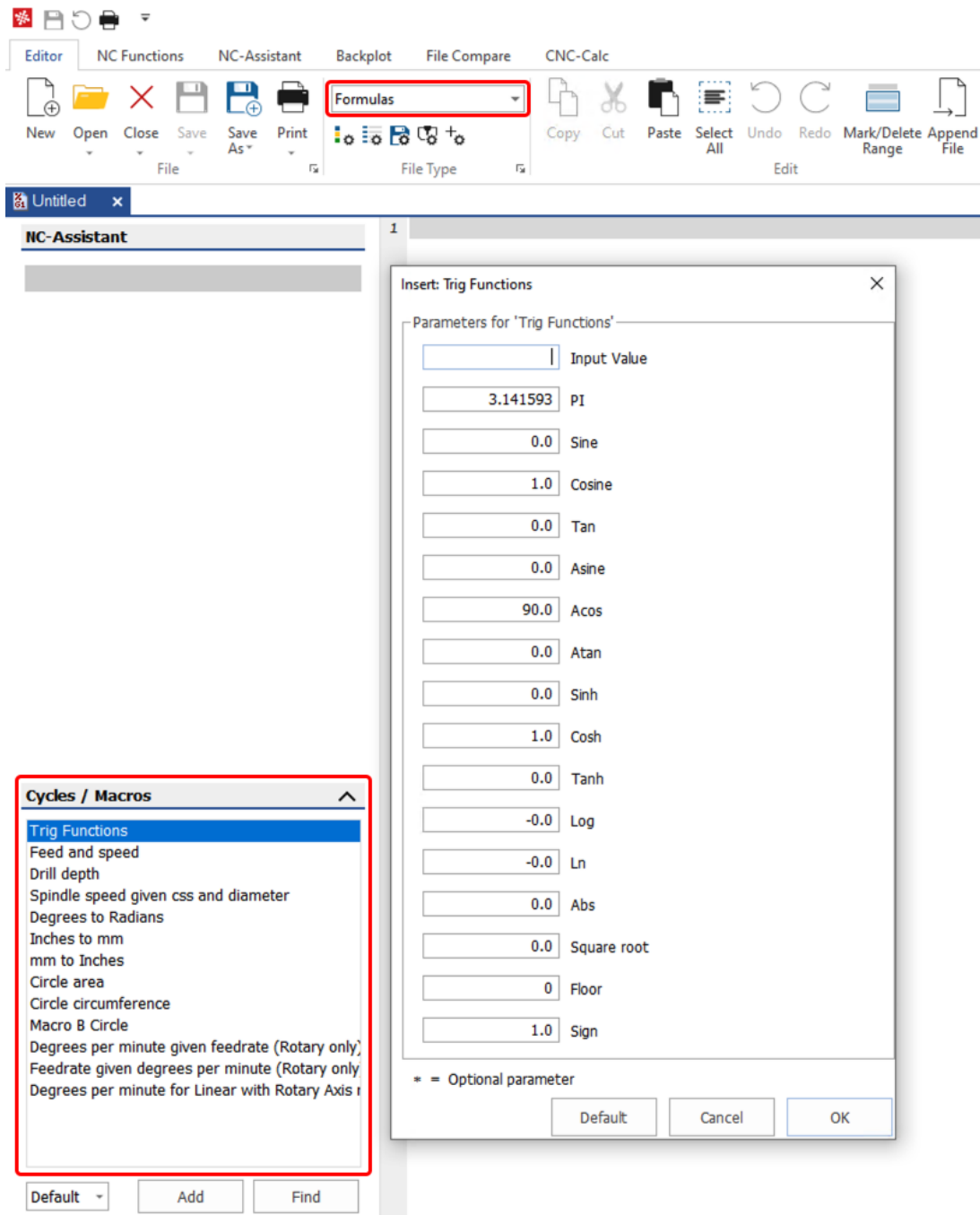

Sample formulas.

The formulas are used much the same as variables, and are written @N as opposed to \$N (with 'N' being a number), and allow the same formatting. To add a formula, enter the [Macro Setup](#) and click the **Add Formula** button. Write your formula inside the curly brackets { }.

- + (plus), - (minus), * (asterisk), / (forward slash) and % (for modulus)
- Nested expressions using ()
- abs, acos, asin, atan, cos, cosh, floor, ln, log, sign, sin, sinh, sqrt, tan and tanh.

If you only want to insert the result of a formula into the NC program, simply create a one line macro and include all your user input values and calculations inside the formula expression { }. When inserting the macro, the *Insert* dialog will show the result of the calculation and you can click OK to insert it into you program.

@2{PI*\$1*\$1}

This formula takes the user input value \$1 and multiplies it by itself and then multiplies it by Pi.

The *PI* math function is used here instead of entering 3.1416. Angles are in degrees.

Please use parenthesis () for the input values in the trigonometric functions, e.g. sin(\$1)

You can hide the results of formulas, which are shown in the *Insert* dialog as fields by default. This can either be set globally for all macros (under the [Editor Setup/General/NC-Assistant](#)) or individually for a macro (in the [Macro Setup](#) dialog).

Hide formula results globally by opening the [Editor Setup/General/NC-Assistant](#) dialog and selecting the checkbox *Hide NC-Assistant formula results*.

Hide formula results individually by opening the [Macro Setup](#) dialog and selecting the checkbox *Hide formula results (in entire macro)* for a specific macro.

If the *Hide NC-Assistant formula results* is selected in Editor Setup, it will override the option in the Macro Setup dialog.

4.3.5. Multi Channel

This section describes the options in the *Multi Channel* menu.

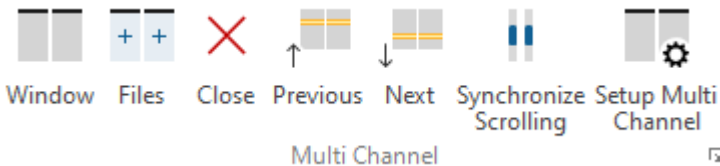

Multi Channel menu.

To use the Multi Channel options you must first configure [Multi Channel](#) in the Editor Setup for the specific File type.

The Multi Channel option enables you to simultaneously view an NC program for machines with two or more channels. Channels are displayed side-by-side in separate editor windows, and the feature also incorporates the synchronization provided by Wait codes.

Editing can be done in all channel windows and, by default, *Wait codes* that match are shown in yellow while missing wait codes are shown in purple.

Menu options



Select this option to view the current program in Multi Channel mode.



Select this option to view multiple files in Multi Channel mode.

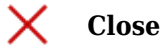

Select this option to close the Multi Channel view.



Jump to the next synchronization point.

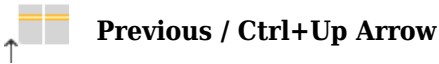

Jump to the previous synchronization point.



Use this option to lock scroll all channels at the same time.



This option will open the [Multi Channel](#) configuration dialog in the Editor Setup.

You can also access the configuration using the icon .

4.3.6. NC-Assistant Sidebar

The NC-Assistant Sidebar streamlines the process of updating macro parameters, adapting swiftly to your selections within the NC code. It also displays a list of macros that correspond to the chosen *File Type* and *Macro Group*, simplifying the task of inserting macros whenever necessary.

You can toggle the visibility of the sidebar in the *info* menu.

NC-Assistant

G1 Linear interpolation (cutting feed)

X-Axis motion command:

Y-Axis motion command:

Z-Axis motion command:

A-Axis motion command:

B-Axis motion command:

C-Axis motion command:

Feedrate:

Modify

Cycles / Macros

Program Start and End

Tool change

Program comment

G0 Positioning (rapid traverse)

G1 Linear interpolation (cutting feed)

G2.1 Circular thread cutting B CW

G2.2 Involute interpolation CW

G2.3 Exponential interpolation CW

G2.4 3-dimensional coordinate system conversion

G2 Circular interpolation CW or helical interpolati

G3.1 Circular thread cutting B CCW

G3.2 Involute interpolation CCW

G3.3 Exponential interpolation CCW

G3.4 3-dimensional coordinate system conversion

G3 Circular interpolation CW or helical interpolati

G4 Dwell

System

Add

Find

NC-Assistant sidebar

NC-Assistant section

Dynamic Parameters List

Lists the parameter fields for the macro associated with the selected line or block. Changes in these fields are

immediately reflected in your code.

Modify

Click the *Modify* button to open the [Modify Macro](#) dialog.

Cycles/Macros section

Cycles/Macros List

Lists the macros available for the currently selected [File Type](#) and [Macro Group](#) (see dropdown below). Click to select a macro or double-click to insert it in your code at the cursor location.

Macro Group

Use this dropdown to select a *Macro Group*. *Macro Groups* can be configured in the [Macro Setup](#) dialog.

Add

Click this to insert the selected macro in your code at the cursor location.

Find

Click this to find the next occurrence of the selected macro.

4.4. Backplot

This section describes the options in the **Backplot** tab.

Please refer to the [Simulation](#) section for information about everything related to simulation in CIMCO Edit 2026.

4.4.1. Backplot

This section describes the options in the *Backplot* menu which are used for simulation and general backplot settings.

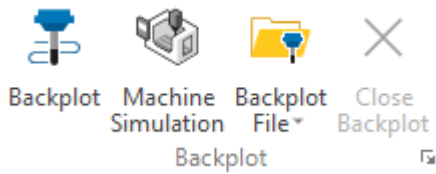

Backplot menu.

Menu options



Backplot / Ctrl+Shift+P

Select this option to simulate the current NC program. The simulation window will open where you can see the NC program (left), the simulation (center) and the docking pane with the [Geometry Manager](#) (right) simultaneously.



Machine Simulation

Select this option to simulate the current NC program in Machine Simulation.

Machine Simulation is an add-on for CIMCO Edit 2026. You will only see this option with a valid license for Machine Simulation installed. See [Machine Simulation](#) for further information.



Backplot File

Enables you to backplot a file directly from disk, without opening the file first. When using this function the NC code will not be shown simultaneously.

Click the dropdown arrow below the icon to display a list of recently opened programs.



Close Backplot / Ctrl+Shift+Q

Use this option to close the simulation window / backplot.

Backplot Setup

Click this to enter the [Backplot configuration](#) dialog in the Editor Setup.

4.4.2. View

This section describes the options in the *View* menu which are used for navigating and visualizing the simulation.

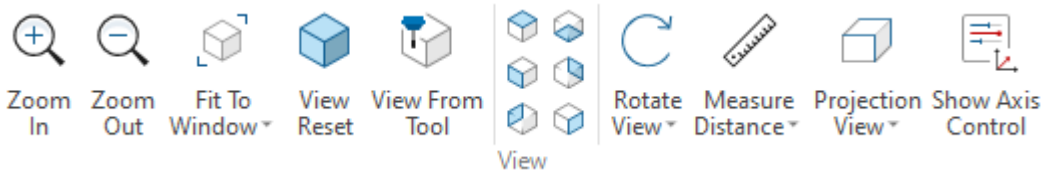

View menu.

Menu options

Zoom In / Mouse Wheel

Click this option to enlarge the view by zooming in.

Zoom Out / Mouse Wheel

Click this option to reduce the view by zooming out.

Fit To Window / Mouse Middle Button

Click this option to adjust the view to show all elements while maintaining the current perspective.

Zoom Selection

Click this option to zoom in on a selected area. After selecting the option, click and hold the mouse button to draw a box around the region you want to magnify.

Zoom To Highlighted

Click this option to zoom in on the currently highlighted (active) element in the simulation.

To see the highlighted element, enable the *Highlight Element* option under [Toolpath](#). Click the down arrow to show the options.

Once enabled, the simulation will highlight each toolpath element sequentially as it runs the program.

View Reset

Click this option to reset the view to the initial size and position.



View from Tool

Click this icon to view the simulation from the tool.



View from Top (XY/G17)

Click this icon to view the simulation from the top.



View from Bottom (XY)

Click this icon to view the simulation from the bottom.



View from Front (XZ/G18)

Click this icon to view the simulation from the front.



View from Back (XZ)

Click on this icon to view the simulation from the back.



View from Left (YZ/G19)

Click on this icon to view the simulation from the left.



View from Right (YZ)

Click this icon to view the simulation from the right.



Rotate View

Select this option to enable view rotation by clicking and holding the left mouse button.

Select this option to enable view zoom by clicking and holding the left mouse button. Move the mouse up to zoom in and down to zoom out.

 **Pan View**

Select this option to enable view panning by clicking and holding the left mouse button.

 **Measure Distance**

Click this option to measure the distance between 2 points.

Fast Version

When enabled, a dedicated measurement panel will appear on the left side of the simulation window with details of your measurement.

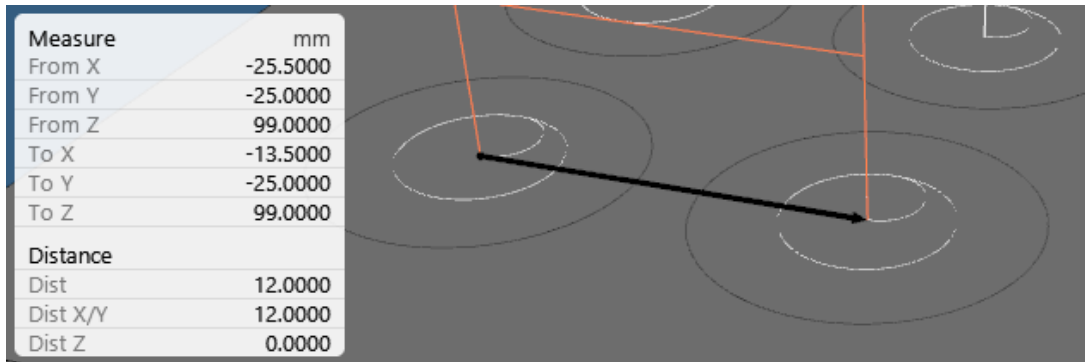

To carry out a measurement:

1. Click on the starting point for the measurement within the simulation.
2. Click on the endpoint you wish to measure towards.
3. To conduct another measurement, simply repeat the process.

After a distance has been measured, you can navigate the view (rotate, zoom, etc.) without the measurement arrow being removed.

See [Simulation \(Fast Version\)](#) for more information about the panel.

Standard Version

In the *Standard version* you can see the details of your measurement in the *Information Bar* at the bottom of the simulation window.

Dist. :	59.867	From X:	-80.764	To X:	-108.171
Dist. X/Y:	27.417	From Y:	-1544.601	To Y:	-1545.356
Dist. Z:	53.219	From Z:	-418.337	To Z:	-471.556

1. Click the starting point for the measurement within the simulation.
2. Move the cursor to the endpoint you wish to measure towards (do not click).
3. See your measurement data in the *Information Bar*
4. To conduct another measurement, simply repeat the process.

In Standard version, a click will always restart the measurement.

See [Simulation \(Standard Version\)](#) for more information about the panel.



Show Bounding Box

Select this option to show the toolpath bounding box.



Show Machine Origin

Select this option to show the machine origin.



Show Toolpath Origin

Select this option to show the toolpath origin.



Show Plot Control

Select this option to show/hide the plot control.



Projection View

Select this option to render the simulation while preserving the relative size of geometries. This makes it easier to compare the geometries at different depths.



Perspective View

Select this option to render the simulation using a camera position and a field of view. The camera can move through geometries for better inspection of fine details. However, geometries far away appears smaller on the screen, making it harder to compare the relative size of objects.



Show Axis Control

Axis Control allows you to track the position of each axis during the simulation. Any axis that runs over its travel limit is highlighted in red.

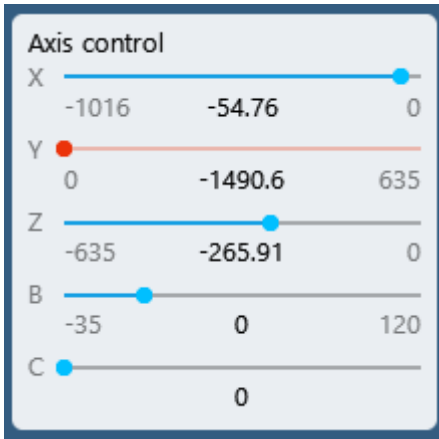

Scroll the mouse wheel on each Axis Control Bar to zoom in and out which allows you to make fine adjustments and see it update in real time.

The Axis Control panel is located at the upper-right corner of the simulation window. See [Simulation \(Fast Version\)](#) for more information.

4.4.3. Toolpath

This section describes the options in the *Toolpath* menu which are used for controlling and visualizing the simulation of toolpaths.

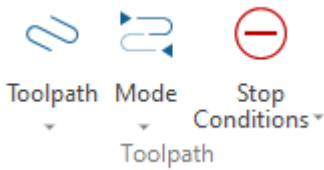

Toolpath menu.

Menu options

Toolpath

Select this option to toggle the visibility of toolpaths.

Click the down arrow to access a variety of toolpath display options.

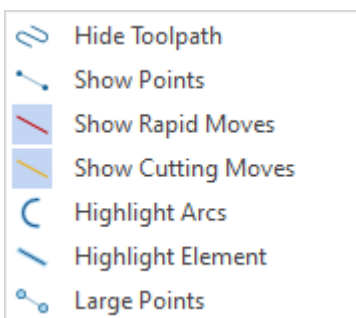

Toolpath options.

 **Hide Toolpath**

Hides the entire toolpath.

 **Show Points**

Shows the individual points that make up the toolpath.

 **Show Rapid Moves**

Shows the rapid, non-cutting movements of the tool.

 **Show Cutting Moves**

Shows the actual cutting movements of the tool.

 **Highlight Arcs**

Highlights arc movements in the toolpath.

 **Highlight Element**

Highlights the current elements of the toolpath simulation.













 **Large Points**

Enlarges the points on the toolpath for better visibility and differentiation from other elements.

 **Mode**

Show toolpath from start until current position.

Click on the down arrow to open a drop-down menu, from which you can select options and additional functions for toolpath simulation.

	Animate / Show From start
	Animate / Show Remaining Toolpath Dimmed
	Animate / Show To End
	Animate / Show Entire Z-Level
	Animate / Show Current Z-Level
	Animate / Show Tail
	Animate / Show From Last Rapid
	Animate / Show From Last Tool Change
	Animate Tool Only
	Remember Animation Mode Between Sessions
	Track Tool
	Loop Simulation

Options for toolpath simulation.

Animate / Show From start

Begins the simulation by only displaying the initial segment of the toolpath. Subsequent toolpaths become visible progressively as the machining process unfolds.

Animate / Show Remaining Toolpath Dimmed

Runs the simulation while dimming the unprocessed part of the toolpath.

Animate / Show To End

Begins the simulation by displaying all toolpaths and then gradually hides the completed sections of the toolpath.

Animate / Show Entire Z-Level

Shows all toolpaths at the current Z-level.

Animate / Show Current Z-Level

Shows the current toolpath at the current Z-level.

Animate / Show Tail

Shows only a part of the toolpath following the tool.

Animate / Show From Last Rapid

At any point in the simulation, this option hides the toolpaths preceding the previous rapid move.

Animate / Show From Last Tool Change

At any point in the simulation, this option hides the toolpaths preceding the previous tool change.

Animate Tool Only

Shows the entire toolpath while only animating the tool.

Remember Animation Mode Between Sessions

Select this option to remember the animation *Mode* after closing Backplot and starting it again. Otherwise it will reset to its default.

Track Tool

Follows the tool and ensures the simulation maintains the tool's position at a fixed point on the screen.

Loop Simulation

Repeats the simulation until stopped by the user.

Stop Conditions

Select this option to toggle Stop Conditions which force the simulation to stop when specific events occur.

Click the down arrow to select which events should stop the simulation. See options below.

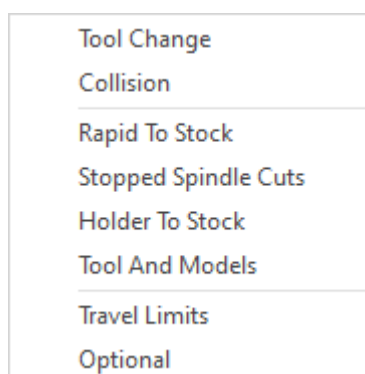

Stop Condition options.

See [Simulation \(Fast Version\)](#) for information about the Stop Conditions panel in the Simulation Window.

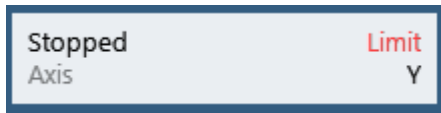

The Stop Conditions option is only available for [Machine Simulation](#).

Tool Change

Enable this to stop the simulation upon detecting a tool change.

Collision

Enable this to stop the simulation upon detecting a collision.

Rapid To Stock

Enable this to stop the simulation upon detecting a rapid movement that collides with the stock.

Stopped Spindle Cuts

Enable this to stop the simulation upon detecting the tool cutting while the spindle is stopped.

Holder To Stock

Enable this to stop the simulation upon detecting a collision between the tool holder and stock.

Tool And Models

Enable this to stop the simulation upon detecting a collision between the tool and any model in the simulation such as workpiece, fixture or machine models.

Travel Limits

Enable this to stop the simulation upon detecting that an axis has exceeded its travel limit.

Optional

Enable this to stop the simulation upon detecting a stop command in the NC program.

- M00: Program Stop
- CIMCO Edit 2026 User Guide

- M01: Optional Stop
- M02: End of Program
- M30: Program End and Reset

4.4.4. Tool

This section describes the options in the *Tool* menu which are used for configuring and visualizing tools in the simulation.

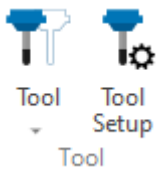

Tool menu.

Menu options



Show/Hide Tool

Select this item to show or hide the simulation tool.

Click the down arrow to access a variety of tool display options.

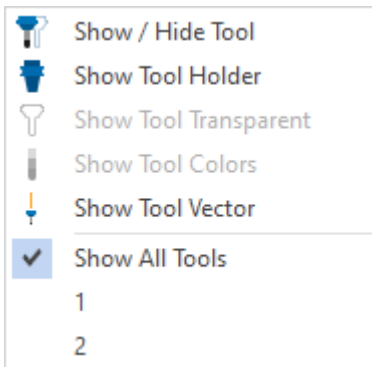

Show Tool Holder

Select this item to show the toolholder.



Show Tool Transparent

Select this item to show the tool transparent.



Show Tool Colors

Select this item to show the tool colors.

Show Tool Vector

Select this item to show the tool vector.

Show All Tools

If multiple tools are used in the program, each one will be visible throughout the simulation.

Tool 1-N

Show/hide individual tools in the simulation.



Tool Setup (Tool Manager)

Click this icon to open the Tool Manager. View and modify the tools in your NC program, configure tool types, colors, and more. Please refer to [Tool Manager](#) for further information.

4.4.5. Solid

This section describes the options in the *Solid* menu which are used for simulation of a solid model.

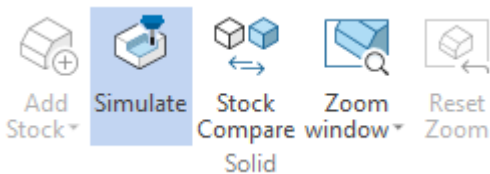

Solid menu.

Menu options



Add Stock

Click on this icon to insert a rectangular stock model.

CIMCO Edit will insert a default stock model based on the toolpath data in the NC program. The stock model can be located in the [Geometry Manager](#) where its dimensions and other properties can be customized. By default, this option is similar to the *Dimensions* option below.

If stock model scanning is enabled in the Editor Setup under [Scanning](#) the behaviour of the *Add Stock* option will be different. In this case, stock type and dimensions can be scanned (imported) automatically from either the NC program or a Setup file associated with the NC program. This depends on how Scanning is configured.

Please refer to [Scanning](#) for further information about how to configure this.

Click the down arrow to see additional options.

Add Stock

This option is the same as the *Add Stock* above.

Dimensions

Select this option to insert a rectangular stock with dimensions based on the toolpath data alone.

In the [Geometry Manager](#) under *Properties*, the stock is defined by a height, width and length which is centered on a position in XYZ relative to an origin.

This option does not use [Scanning](#).

Min/Max

Select this option to insert a rectangular stock with dimensions based on the toolpath data alone.

In the [Geometry Manager](#) under *Properties*, the stock is defined by two points; a *Lower Corner* and an *Upper Corner*. Both points are defined relative to a position in XYZ.

This option does not use [Scanning](#).

Cylinder

Select this option to insert a cylinder shaped stock with dimensions based on the toolpath data alone.

In the [Geometry Manager](#) under *Properties*, the stock is defined by a center position, diameter and height. You can further define its *Axis* and *Origin*.

This option does not use [Scanning](#).

STL

Select this option to load and insert the stock from an STL file. Simply click the option, locate and open the STL file. It will then be inserted into the simulation and show in the [Geometry Manager](#).

This option does not use [Scanning](#).

DXF

Select this option to load and insert the stock from an DXF file. Simply click the option, locate and open the DXF file. It will then be inserted into the simulation and show in the [Geometry Manager](#).

This option does not use [Scanning](#).



Simulate

This option requires that a stock model has been added.

Fast version

Enable this option to continuously update the solid model of the stock during simulation playback to reflect the expected machining outcome. Stock is also updated to reflect changes made in the Geometry Manager.

Disable this option to stop the stock from updating.

Standard version

When using the *Standard version* simulation, the stock is always updated to reflect the expected machining outcome. This cannot be disabled.

However, if you move the simulation backwards to an earlier point in your NC program, the stock will not update to reflect this. This is by design.

Click this option to regenerate (refresh) the solid model of the stock based on the current position in the NC program. This can also be done by right-clicking the stock in the [Geometry Manager](#) and selecting *Regenerate*.

If you make changes to the stock in the Geometry Manager, a red wireframe will show instead to indicate the stock must be regenerated. Do this the same way as described above.



Stock Compare

Select this option to compare the stock to a design model (Workpiece). The stock is color-coded based on its distance to the design model to easily identify any inaccuracies, whether too much stock has been removed (the tool gauges the design model) or where not enough stock has been removed.

- Red color indicates areas where the stock has been over-machined and too much material has been removed
- Blue color indicates areas where the stock has been under-machined and too little material has been removed
- Green color indicates the stock is within tolerance
- Hover the mouse over the colored stock to see the distance to the design model in different areas

To use Stock Compare it is necessary to set up both the Stock and a Workpiece in the [Geometry Manager](#). The Workpiece should be an STL model representing the desired final product for comparison with the machined stock.

Under the [Simulation tab](#) in the docking pane (right side of screen), you can change the default Stock Compare settings for *Compare range* and *Stock to leave*.

- **Stock to leave** is the expected difference. For example, if you expect to leave 1mm of material for a later process, you can set this to 1.
- **Compare range** refers to the tolerance range within which the stock is considered to be machined correctly. If set to 1mm, a difference below -1 will show all red and above 1 will show all blue.

Please see [Simulation \(Fast Version\)](#) for information about how Stock Compare is used in the simulation window.

Please note that the Cross Section View, which is a feature in the Geometry Manager tab, also has an option to compare the stock and workpiece. Please see the [Geometry Manager](#) tab for more information.

Stock Compare is only available for Fast version simulation.



Zoom Window

Select this option to increase the accuracy of the stock within the simulation window. This option creates a cut out of the stock that covers the window.

Use the *Reset Zoom* option to show the entire stock.

Only available for Fast version simulation.



Zoom Selection

Select this option to increase the accuracy of the stock within a user-defined area.

1. Select this option
2. In the simulation window, click and hold the left mouse button
3. Drag out a rectangle.
4. Release the mouse to make the cut out.

Use the *Reset Zoom* option to show the entire stock.

Only available for Fast version simulation.



Reset Zoom

Select this option to reset the simulation window when using *Zoom Window* or *Zoom Selection*.

Only available for Fast version simulation.

4.4.6. Control Type

This section describes the options in the *Control Type* menu which are used for setting the *Control Type*, *Machine Setup* and see supported axes.

The *Machine* (Machine Setup) must be selected before starting Backplot or Machine Simulation.



Control Type menu.

Menu options

Control Type

Use this dropdown to select the control type on the machine you wish to simulate.

Control Type for specific file types can be configured in the [Backplot](#) section in the Editor Setup.

Machine (Machine Setup)

Use this dropdown to select the machine setup you wish to simulate.

Machine setup for specific file types can be configured in the [Backplot](#) section in the Editor Setup.

Axes support (X, Y, Z, A, B, C)

Indicates the axes that are supported by the currently selected *Machine Setup*.

4.4.7. Other

The Other menu contains functions for entering full screen, DXF export, and simulation control type.

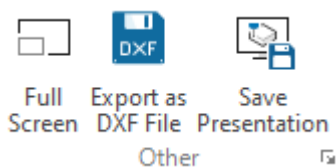

Other menu.

Menu options

Full Screen

Select this option to show the simulation window in full screen. Use the *Escape* key or right-click menu in the simulation window to exit full screen.



Export as DXF File

Select this to export the toolpath data in DXF format. DXF is short for Drawing Exchange Format or Drawing Interchange Format and is a type of vector file.

DXF export can be configured in the [Other](#) section in the Editor Setup.



Save Presentation

Select this option to export the entire simulation for viewing as a 'stand-alone' simulation without needing CIMCO Edit.

You can save a presentation in two ways:

1. **Simulation File:** Only includes the simulation
2. **Presentation Bundle:** Includes both the simulation and the [Presentation Viewer application](#) (can also be used to send the simulation setup to CIMCO support)

The Presentation Viewer viewer application only have to be installed once and can then be used to view different simulations exported from CIMCO Edit.

Simulation files only contain simulation data and are useful for storing alongside other documents related to an NC program such as setup sheets and tool lists. They also have a relatively small filesize making them easy to share.

Other Setup

Select this option to open the [Other](#) setup dialog in the Editor Setup.

4.4.8. Find

The Find section contains functions for searching (and replacing) through the active file.

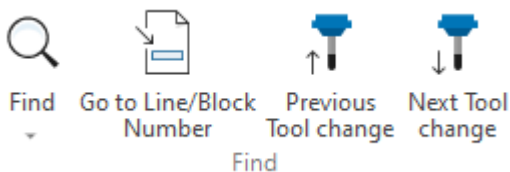

Find menu.

Menu options



Find / Ctrl+F

This option is similar to [Find](#) under the *Editor* tab.



Find Previous / Shift+F3

This option is similar to [Find Previous](#) under the *Editor* tab.



Find Next / F3

This option is similar to [Find Next](#) under the *Editor* tab.



Go to Line/Block Number / Ctrl+J

This option is similar to [Go to Line/Block Number](#) under the *Editor* tab.



Next Tool Change

This option is similar to [Next Tool Change](#) under the *Editor* tab.



Previous Tool Change

This option is similar to [Previous Tool Change](#) under the *Editor* tab.

4.5. File Compare

This section describes the options in the **File Compare** tab.

4.5.1. File Compare

This section describes the options in the *File Compare* menu which are used for comparing files.

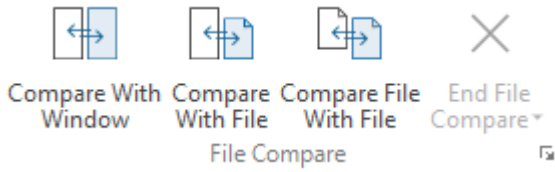

File Compare menu.

Menu options

Compare with Window

Compares the file in the current window with a file in another. When more than two files are open, CIMCO Edit will ask you to select the file you want to compare with.

Compare with File

Compares the file in the current window with a file. The other file is opened through the *Open file* dialog.

Compare File with File

Compares two files which are not already in a window. The files are opened using the *Open file* dialog.

End File Compare

The file compare session is stopped and both files are left open.

Close Left Window

Select this to close the file compare window on the left side.

Close Right Window

Select this to close the file compare window on the right side.

Select this to enter the [File Compare](#) section in the Editor Setup.

4.5.2. Go To

This section describes the options in the *Go To* menu which are used to step through the differences found during a file compare.

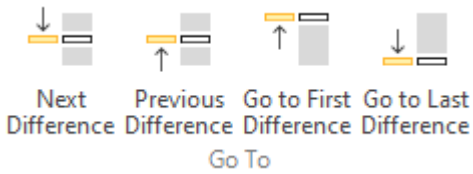

Go To menu.

Menu options



Select this to go to the next difference.



Select this to go to the previous difference.



Select this to go to the first difference.



Select this to go to the last difference.

4.5.3. Sync

This section describes the options in the *Sync* menu which are used to synchronize differences.

When you synchronize a difference, the selected difference is copied from one window to another. The options described below determine the synchronization direction (from right to left or from left to right).

When the text is moved from one to another window, the line is no longer highlighted. This is because the texts in both windows are identical after synchronization.

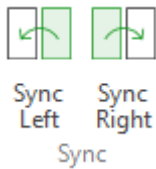

Sync menu.

Menu options

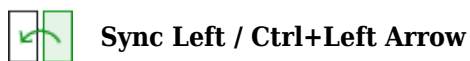

Synchronizes current difference from right to left window.

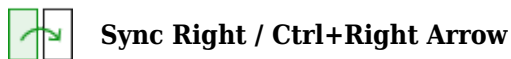

Synchronizes current difference from left to right window.

4.5.4. Other

This section describes the options in the *Other* menu.

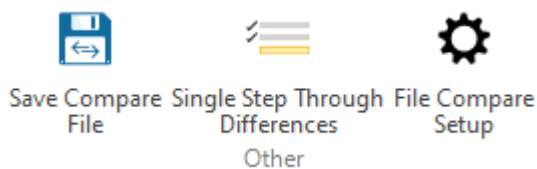

Other menu.

Menu options



Select this option to save lines with differences to a .txt file.

Single Step Through Differences

Enable this option to only synchronize the line where the cursor is positioned.

By default, CIMCO Edit synchronizes blocks of lines, such as where two or three consecutive lines contain differences. By enabling this option, you can focus on one line at a time.

File Compare Setup

Select this to enter the [File Compare](#) section in the Editor Setup.

4.6. Transmission

This section describes the options in the **Transmission** tab.

CIMCO Edit enables the transfer (sending and receiving) of NC programs to and from CNC machines through serial or FTP connection.

- For transfers via serial refer to [Standard Serial Protocol](#).
- For transfers via FTP refer to [FTP Client Protocol](#).

Both serial and FTP are configured in the [DNC Setup](#) dialog which can be opened from the *Transmission* menu or the *Setup* menu under the Transmission tab. The DNC Setup dialog is separate from the Editor Setup and cannot be accessed from this.

CIMCO Edit 2026 must be licensed for DNC operations to use this option.

4.6.1. Transmission

This section describes the options in the *Transmission* menu which are used to send and receive programs to and from CNC machines.

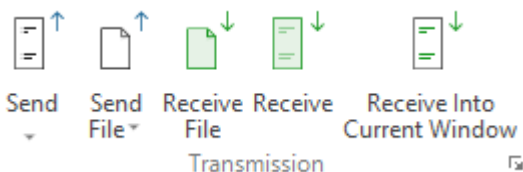

Transmission menu.

Menu options

 **Send**

Select this option to send the current NC program to the machine selected in the dropdown in the *Machine* menu.

The [Transmit status](#) dialog will appear showing the transfer status.

Click the down arrow to see additional options.

This option is not available for FTP.

 **Send Selected Lines**

Select this option to send a selected block of lines to the machine selected in the dropdown in the *Machine* menu.

The [Transmit status](#) dialog will appear showing the transfer status.

This option is not available for FTP.

 **Send File**

Use this option to locate a file and send it to the machine selected in the dropdown in the *Machine* menu.

For serial, the [Transmit status](#) dialog will appear showing the transfer status.

For FTP, the [FTP Transfer](#) dialog will appear, however, only if the option *Use split window* is enabled under [Send/Receive Settings](#) in the DNC Setup for the FTP Client Protocol.

Click the down arrow to see a list of recently sent files.

 **Receive File**

Select this option to receive an NC program from the machine selected in the dropdown in the *Machine* menu. The file will be saved without opening it.

1. Select this option to open the *Receive File* dialog
2. Locate the folder where the file should be saved to
3. Enter a filename and select a file type
4. Click the *Save* button
5. The [Receive status](#) dialog will appear showing the transfer status

When using FTP, the [FTP Transfer](#) dialog will show when receiving a file from an FTP server.

Click the down arrow to see a list of recently received files.



Receive

Select this option to receive an NC program from the machine selected in the dropdown in the *Machine* menu. The program will be opened in a new window.

The [Receive status](#) dialog will appear showing the transfer status.

This option is not available for FTP.



Receive Into Current Window

Select this option to receive an NC program from the machine selected in the dropdown in the *Machine* menu. The program will be inserted into the current window.

The [Receive status](#) dialog will appear showing the transfer status.

This option is not available for FTP.

DNC Setup

Click this to open the [DNC Setup](#) dialog.

4.6.2. Machine

This section describes the options in the *Machine* menu which are used select the machine you want to send to or receive from.

Machines are configured in the [DNC Setup](#) dialog.



Machine

Machine menu.

Menu options

Machine Type

Use this dropdown to select the machine you want to send to or receive from.



Select this option to show the [Transmit dialog](#) (if this has been hidden).

This option is disabled for machines using FTP.

4.6.3. Setup

This section describes the option in the *Setup* menu which is used to open the [DNC Setup](#) dialog.



Setup menu.

Menu options



Select this option to open the [DNC Setup](#) dialog.

4.6.4. Transmit/Receive Dialogs

The Transmit Status and Receive Status dialogs are essentially the same dialog with minor variations to accommodate either sending or receiving operations.

4.6.4.1. Transmit Status Dialog

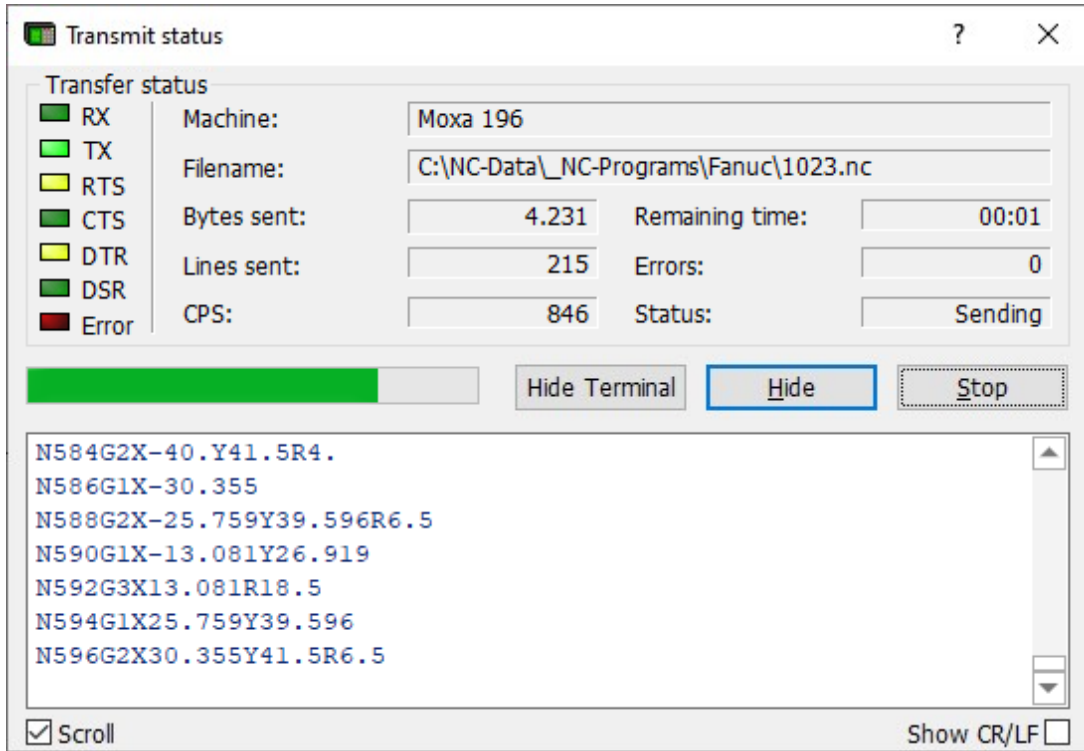

Transmit Status dialog.

Signals (top left)

This section shows the key signals of the serial data transmission according to EIA RS-232-C standard for serial communication. The signals light up when activated.

Information (top right)

This section shows information about the current transmission such as Machine name, Filename, Bytes sent, etc.

Progress Bar

The progress bar indicates the current progress of the transmission from 0 to 100%.

Hide Terminal

Click this button to toggle the Terminal Window at the bottom of the dialog.

Hide

Click this button to hide the dialog. Use the [Status](#) option in the Machine menu to show it again.

Stop

Click this button to stop the transmission. The following dialog will appear asking for confirmation.

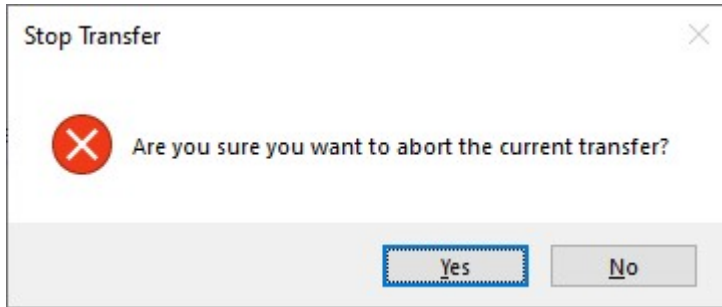

Terminal Window

The Terminal Window shows the NC program being transmitted in plain text.

Options to *Scroll* the text or to *Show CR/LF* (Carriage Return/Line Feed characters) are located below the window.

4.6.4.2. Receive Status Dialog

The Receive Status dialog is mostly similar and functions the same as the Transmit Status dialog.

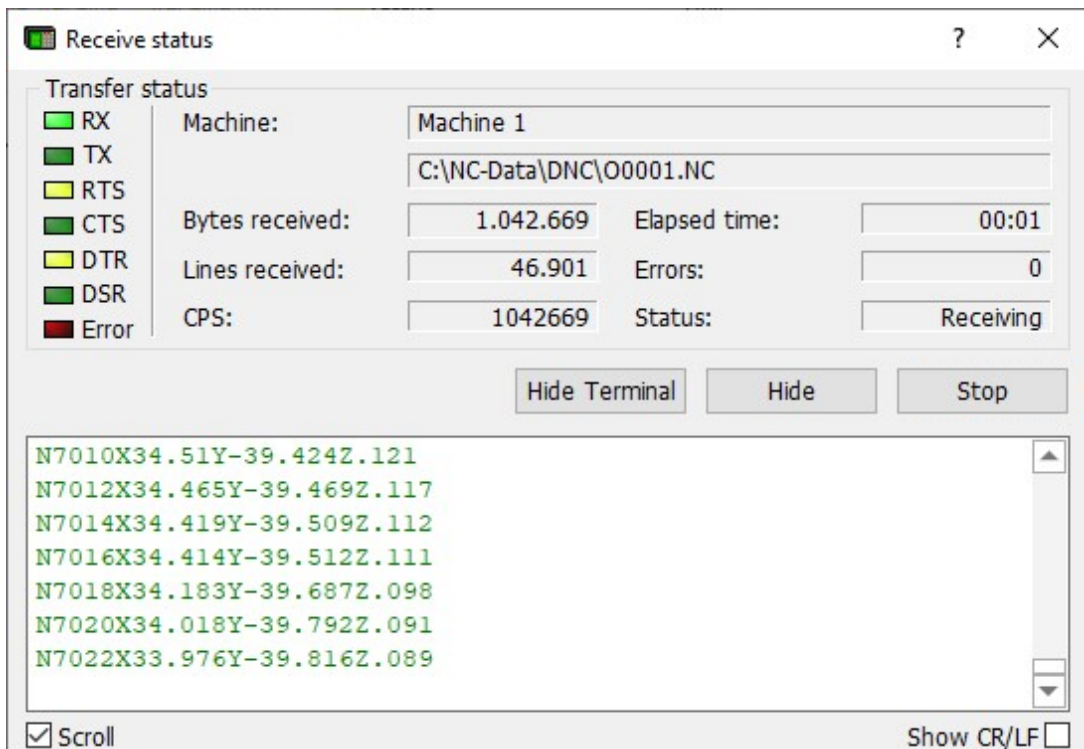

4.6.5. FTP Transfer Dialog (Split Window)

The *FTP Transfer* dialog, also known as the *Split Window*, operates similarly to many FTP clients, displaying the local PC on the left and the remote FTP server (CNC) on the right.

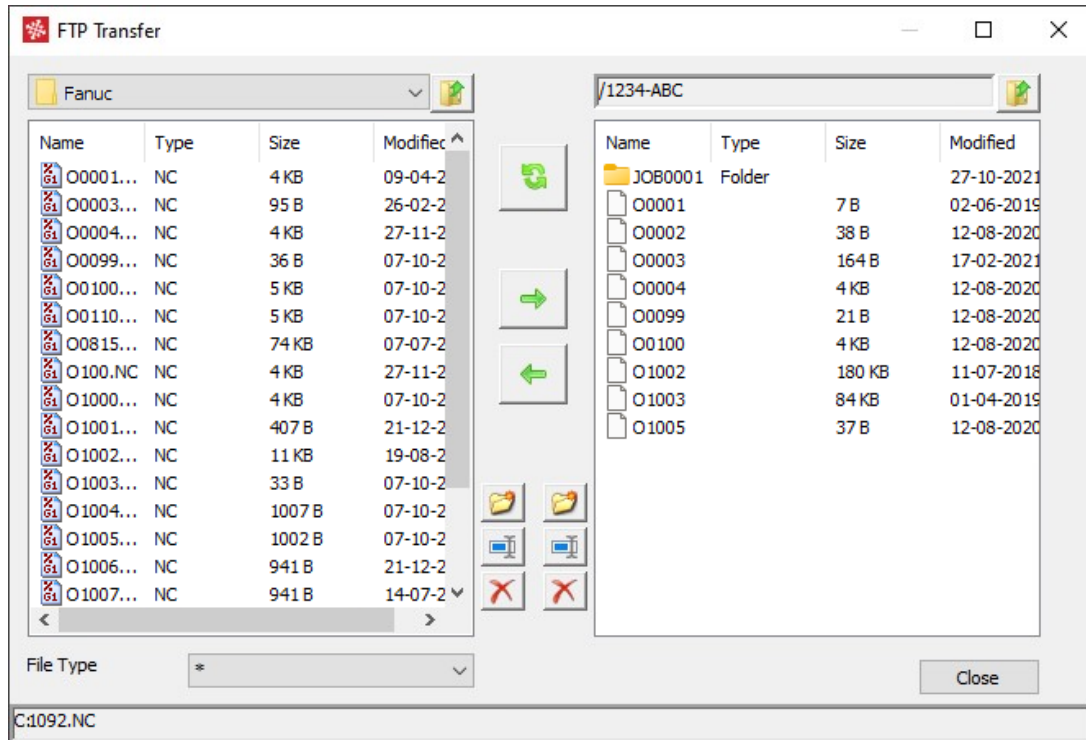

FTP Transfer dialog.

PC path (dropdown on left side)

Use this dropdown to select a path on the local PC or network. Use the folder icon on the right side of the dropdown to go to the parent directory.

When connected, the FTP Transfer dialog shows the contents of the default local directory.

The default local directory can be configured in the [Port](#) section in the DNC Setup.

CNC path (right side)

When connected, the FTP Transfer dialog shows the contents of the default remote directory. Use the folder icon on the right side of the path field to go to the parent directory.

The default remote directory can be configured in the [Port](#) section in the DNC Setup.

Refresh

Click this button to refresh both the local and remote directories.

Arrow pointing right

CIMCO Edit 2026 User Guide

Click this to send the selected file(s) from the local side (PC) to the remote side (server).

Arrow pointing left

Click this to send the selected file(s) from the remote side (server) to the local side (PC).

New folder

Click this button to create a new folder on either the local side or remote side.

The options *Local directory creation* and *Remote directory creation* must be enabled in the [Send/Receive](#) section in the DNC Setup.

Rename

Click this button to rename the selected file or folder on either the local side or remote side.

The options *Local renaming* and *Remote renaming* must be enabled in the [Send/Receive](#) section in the DNC Setup.

Delete

Click this button to delete the selected file or folder on either the local side or remote side.

The options *Local deletion* and *Remote deletion* must be enabled in the [Send/Receive](#) section in the DNC Setup.

Dropdown list for file type (PC side)

Use this field to specify the file type used for sending programs.

5. Simulation

CIMCO Edit 2026 includes two simulation engines; the *Standard version* and the new *Fast version* which is now the default engine. You can change the version in the [Backplot configuration](#) section in the Editor Setup.

Also, before starting the simulation, you first need to configure backplot for the *File type* of the program you wish to simulate. Open the *Backplot configuration* dialog in the Editor Setup, select the *Control Type* (for example 'ISO Milling') and configure the desired parameters. See [Backplot configuration](#) for more information.

Overview of the Backplot tab and simulation window.

- **[Ribbon bar menu \(Backplot\)](#)**: Easy access to relevant simulation options
- **NC program view (left)**: Shows your NC program in sync with the simulation
- **Simulation window (center)**: Shows the actual 3D simulation and controls (using [Fast version](#) or [Standard version](#))
- **Docking pane (right)**: Contains multiple tabs, including:
 - **[Simulation](#)**: Simulation Report and settings
 - **[Navigation](#)**: Overview of NC program
 - **[Variables](#)**: Tracking of variables in your NC code during simulation.
 - **[Geometry Manager](#)**: Setup of elements in the simulation

5.1. Simulation Window (Fast Version)

This section describes the Simulation Window and its user interface elements when using Fast version simulation.

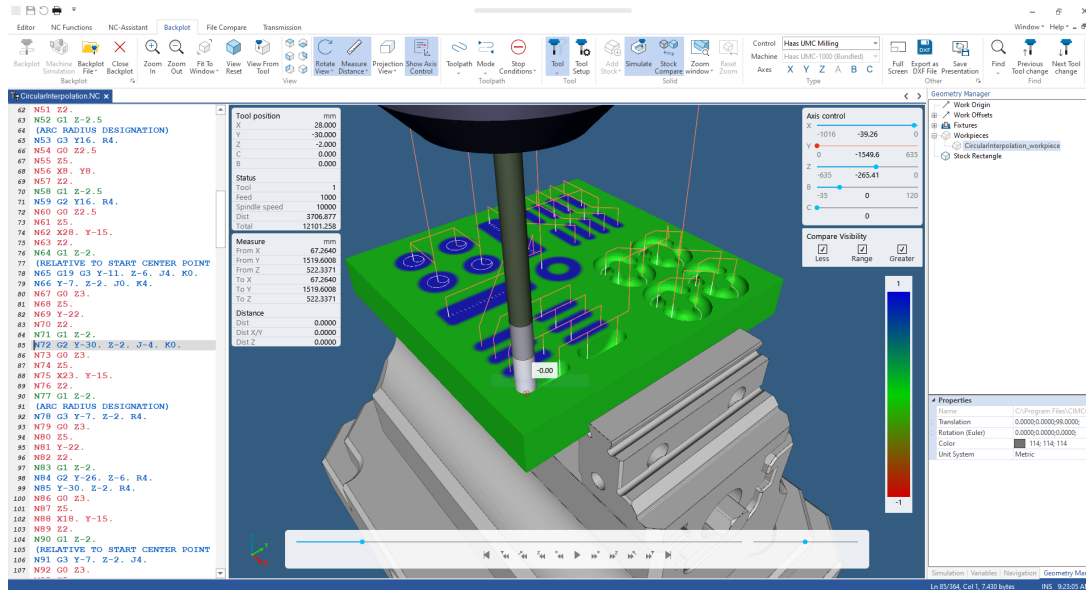

Fast Version simulation window.

Navigate 3D View (Rotate, Zoom and Pan)

- **Rotate View:** Click and hold the left mouse button over the simulation window, then drag to rotate the view around a point of interest.
- **Zoom:** Use the scroll wheel to zoom in for a closer look or out to see more of the simulation.
- **Pan:** To shift your view without changing the orientation, click and hold the right mouse button and move the mouse to pan across the simulation space.

Playback Controls

Progress Bar



The Progress Bar shows the current position in the NC program. Click and drag the blue handle to move the simulation forward or backwards.

Use the mouse scroll wheel to zoom in and out on the Progress Bar for more precise positioning of the slider.

Direction and Speed Slider

When the simulation is started, use this slider to set the direction and speed of playback.

- **Forward:** from midpoint to the right (slow to fast)
- **Backward:** from midpoint to the left (slow to fast)

You can adjust the slider by either dragging it or using the scroll wheel on your mouse.



▶ **Start / Stop simulation**

Select this to start the simulation.

|| **Pause simulation**

Select this to pause the simulation.

▶° **Jump to next move**

Select this to jump to the next move. Use the corresponding option to jump to the previous move.

▶^Z **Jump to next Z-level**

Select this to jump to the next Z-level. Use the corresponding option to jump to the previous Z-level.

▶^s **Jump to next cutting pass**

Select this to jump to the next cutting pass. Use the corresponding option to jump to the previous cutting pass.

▶^T **Jump to next tool**

Select this to jump to the next tool change. Use the corresponding option to jump to the previous tool change.

▶ **Jump to end**

Select this to jump to the end of the simulation. Use the corresponding option to jump to the beginning of the simulation.

Panels

Tool Position and Status Panel

The Tool Position and Status Panel is located at the upper-left corner of the screen, providing easy access to monitor your tool's current position and status.

Tool position	mm
X	13.000
Y	-25.931
Z	-5.999
C	0.000
B	0.000
Status	
Tool	1
Feed	1000
Spindle speed	10000
Dist	3956.137
Total	12101.258

The upper section of the panel shows the current tool's position on each of the available axes such as along X, Y, Z, A, B, and C. The availability of these axes varies depending on machine configuration.

In the lower section under *Status*, the following parameters are shown:

- **Tool:** The current tool number
- **Feed:** The current feed. Simply displays *Rapid* for rapid moves.
- **Spindle speed:** The current spindle speed in revolutions per minute (RPM).
- **Dist:** Shows the current toolpath distance that tool(s) have traveled during the program/simulation.
- **Total:** Shows the total distance of all toolpaths within the program.

The units used for some of these parameters can be configured for individual machine controls in the [Machine](#) section in the Editor Setup.

Stock Compare Panels

The [Stock Compare](#) option is used to compare the stock to a design model (Workpiece). The stock is color-coded based on its distance to the design model to easily identify any inaccuracies, whether too much stock has been removed (the tool gauges the design model) or where not enough stock has been removed.

Compare Visibility

This panel contains three buttons and two options:

- **Less:**
Toggle red color which indicates areas with too little material left.
- **Range:**
Toggle green color which indicates the stock is within tolerance
- **Greater:**
Toggle blue color which indicates areas with too much material left.
- **Compare Range:**
Refers to the tolerance range within which the stock is considered to be machined correctly. If set to 1mm, a difference below -1 will show all red and above 1 will show all blue. See Stock Compare under the [Solid](#) menu for further information.
- **Stock to leave:**
The expected difference. For example, if you expect to leave 1mm of material for a later process, you can set this to 1. See Stock Compare under the [Solid](#) menu for further information.

Compare Range

- **Red color:**
Indicates areas where the stock has been over-machined and too much material has been removed
- **Blue color:**
Indicates areas where the stock has been under-machined and too little material has been removed
- **Green color:**
Indicates the stock is within tolerance
- **Hover the mouse:**
Hover the mouse over the colored stock to see the distance to the design model in different areas

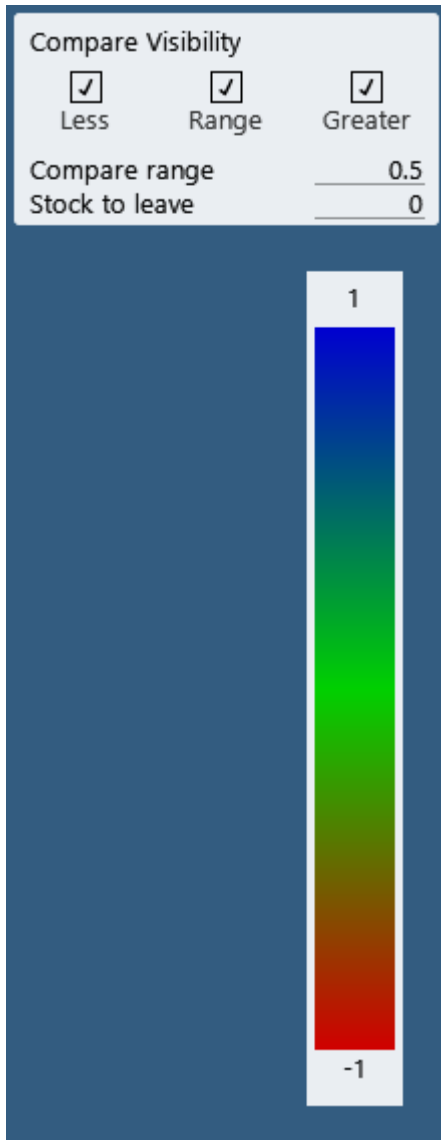

Axis Control Panel

The Axis Control panel is located at the upper-right corner of the screen and allows you to track the position of each axis during the simulation. Any axis that runs over its travel limit is highlighted in red.

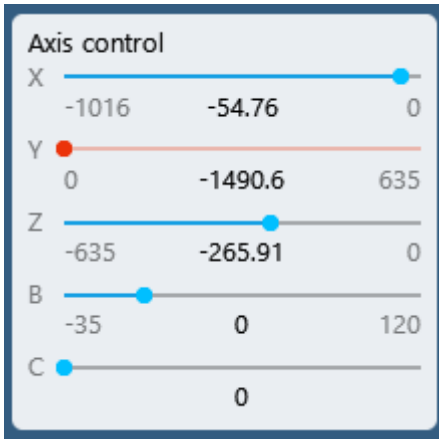

Scroll the mouse wheel on each Axis Control Bar to zoom in and out which allows you to make fine adjustments and see it update in real time.

The option to enable Access Control is located in the Backplot tab under the [View](#) menu.

Quality and True Vision

To show the *Quality and True Vision* panel, select the stock in the [Geometry Manager](#).

Use the *Quality slider* to adjust the rendering precision of the selected stock. A higher setting provides greater accuracy but also increases processing time.

Enable the *True Vision checkbox* to activate advanced pixel-perfect rendering with even higher precision. This mode takes the exact tool profile and other key parameters into account for a more realistic simulation.

True Vision is only visible when the simulation window is stationary. It is temporarily disabled while rotating, panning, or zooming the simulation view.

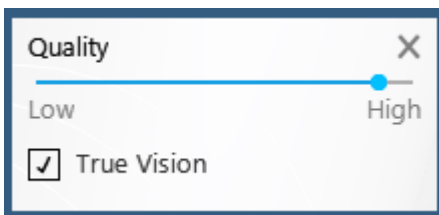

Cross Section Plane Panel

This panel appears when *Cross Section View* is enabled which allows you to slice the stock along an axis. This is enabled in the [Geometry Manager](#) by right-clicking the stock and selecting *Cross Section*.

See [Geometry Manager](#) for more information.

- **X+**
The position of the slice along the X axis. This will change to the axis currently being sliced.
- **Tool Plane:**
Enable this to set the cross sections relative to the current active tool plane.

- **Workpiece:**

Enable this to compare the stock with the workpiece. Red color indicates that too much material has been removed while yellow color indicates too little has been removed.

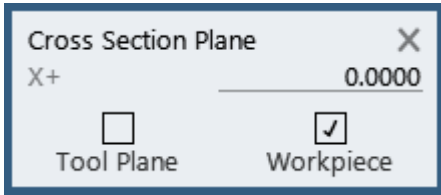

Stop Conditions Panel

When a [Stop Condition](#) is triggered, this panel appears on the right side of the screen with information about the cause of the stop. In this example the simulation has stopped because the Y-axis has traveled beyond its limit.

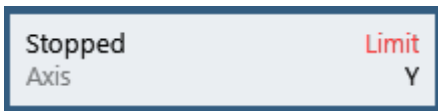

The Stop Conditions option is only available for [Machine Simulation](#).

Measure Distance Panel

This panel appears on the left side when the Measure Distance option is enabled in the Backplot tab under the View menu. The [Measure Distance](#) option is used to measure the distance between 2 points.

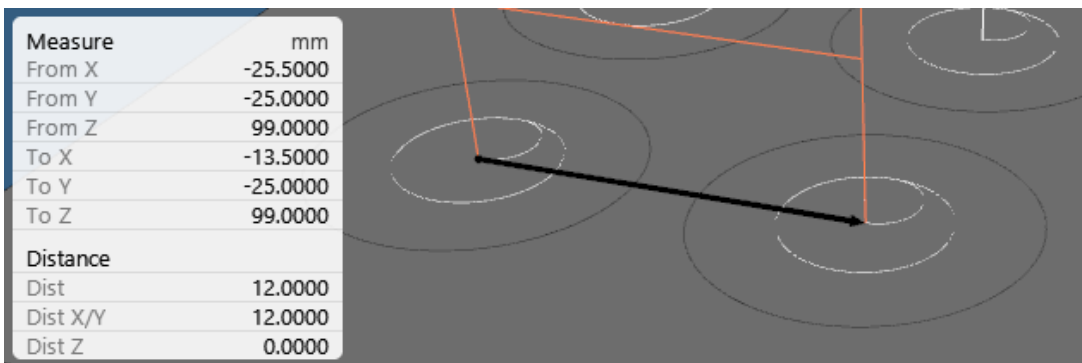

Workpiece Position Panel

Shows the position of origin of the Workpiece. See the option *Select origin in simulation* in the [Geometry Manager](#) for more information.

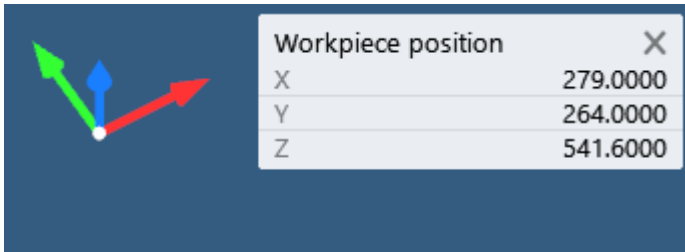

5.2. Simulation Window (Standard Version)

This section describes the **Simulation Window** and its user interface elements when using Standard version simulation.

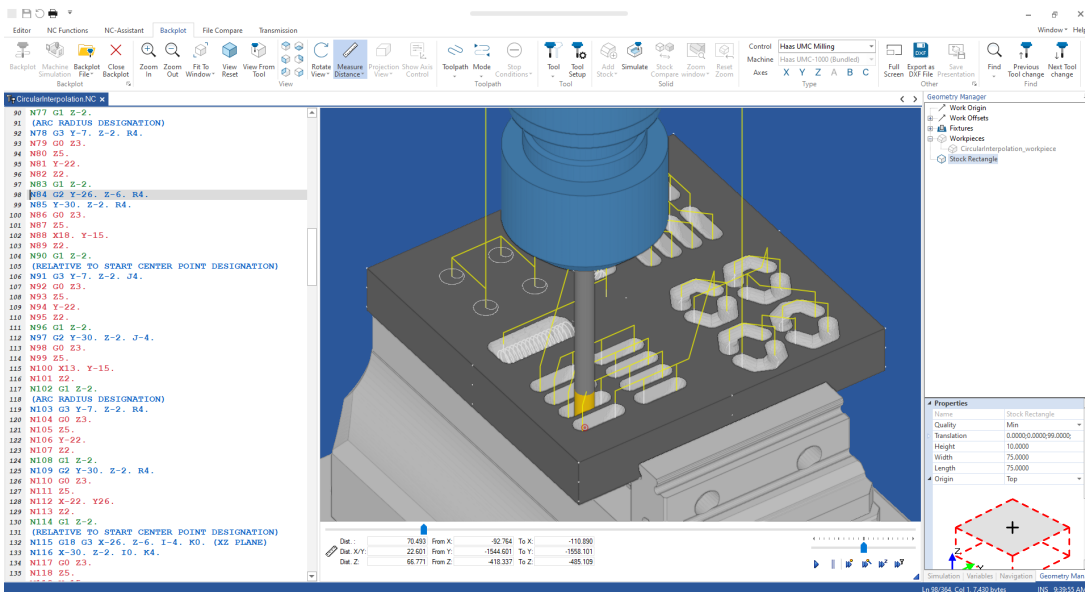

Standard version simulation window.

Navigate 3D View (Rotate, Zoom and Pan)

- **Rotate View:** Click and hold the left mouse button over the simulation window, then drag to rotate the view around a point of interest.
- **Zoom:** Use the scroll wheel to zoom in for a closer look or out to see more of the simulation.
- **Pan:** To shift your view without changing the orientation, click and hold the right mouse button and move the mouse to pan across the simulation space.

Playback Controls

The *Information Bar*, located at the bottom of the simulation window, contains different controls to navigate the simulation and shows tool information based on the current position in the NC program.

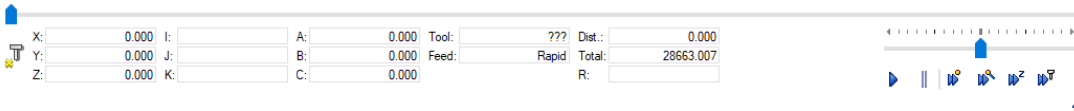

Information Bar.

Progress Bar (0 - 100%)

The Progress Bar shows the current position in the NC program. Click and drag the blue handle to move the simulation forward or backwards.



Speed and Direction Slider

When the simulation is started, use this slider to set the direction and speed of playback.

- **Forward:** from midpoint to the right (slow to fast)
- **Backward:** from midpoint to the left (slow to fast)



Start / Stop simulation

Select this to start the simulation.



Pause simulation

Select this to pause the simulation.



Jump to next move

Select this to jump to the next move. Will jump to previous when *Speed and Direction Slider* is in reverse.



Jump to next cutting pass

Select this to jump to the next cutting pass. Will jump to previous when *Speed and Direction Slider* is in reverse.



Jump to next Z-level

Select this to jump to the next Z-level. Will jump to previous when *Speed and Direction Slider* is in reverse.

This option is not available when simulating a turning program.



Jump to next tool

Select this to jump to the next tool change. Will jump to previous when *Speed and Direction Slider* is in reverse.



Show / hide information bar

Select this to toggle the visibility of the Information Bar.

Tool Data and Measurement

Tool Position and Status

The data fields display the tool data relevant to the current position within the simulated NC program. The fields presented will vary depending on whether the program is designed for milling or turning operations.

X:	0.000	I:		A:	0.000	Tool:	???	Dist.:	0.000
Y:	0.000	J:		B:	0.000	Feed:	Rapid	Total:	28663.007
Z:	0.000	K:		C:	0.000			R:	

Measure Distance

These data fields appears when the Measure Distance option is enabled in the Backplot tab under the View menu. The [Measure Distance](#) option is used to measure the distance between 2 points.

Dist. :	59.867	From X:	-80.764	To X:	-108.171
Dist. X/Y:	27.417	From Y:	-1544.601	To Y:	-1545.356
Dist. Z:	53.219	From Z:	-418.337	To Z:	-471.556

5.3. Simulation Tab

This section describes the **Simulation** tab which is located in the docking pane. The tab is divided into two main areas: the upper section displays the Simulation Report, while the lower section is dedicated to various simulation settings.

5.3.1. Simulation Report

The Simulation Report lists all program errors that have been detected within the NC program, including the line number the error occurs on, the type of error, a description of the error and the action taken. The Simulation Report also provides information about collisions and limits when the [Machine Simulation](#) add-on is being used.

The *ACTION* column describes what action CIMCO Edit will take until the error is resolved such as ignoring a command or highlighting a collision.

Click on any program error in the list to jump to the corresponding line and highlight the error in the NC program.

The Simulation Report automatically updates when changes are made to the NC program and errors are immediately removed from the list when corrected.

Error checking can be disabled under Simulation Settings / Report errors (see below).

Simulation			
START TIME (LINE)	TYPE	MESSAGE	ACTION
00:00:00.000 (12)	Error Message	Invalid value for command	Command ignored
00:00:00.000 (12)	Error Message	Value expected but not found	Command ignored

Simulation Report in upper section of Simulation tab.

Check collision and limit errors

Click this button to rerun collision detection. This task can be CPU intensive, particularly for large programs, so it does not run with each modification to the NC code. Using this button, you can decide when to execute the collision detection.

This option is only available for [Machine Simulation](#).

Show Errors

Enable this option to show error messages in the Simulation Report.

Show Warning

Enable this option to show warnings in the Simulation Report.

5.3.2. Settings

5.3.2.1. Collision Settings

The collision settings only show when [Machine Simulation](#) is enabled.

123 **Collision checking per model**

This function defines whether collision checking should stop after finding the first collision (Find One) or continue to find all possible collisions (Find All) between pairs of machine components. The term "per model" can be a bit misleading, as it actually means "per model pair" - i.e., collisions between two specific components.

- **Find One:** Detects one collision for each type of model pair (e.g., tool/workpiece or C-axis/Z-axis).
 - **Find All:** Detects all collisions for all model pairs. This can potentially be slow.
-

123 **Tool/Workpiece Collisions**

This option controls collision detection between the tool and the workpiece and offers the following settings:

- **ON:** Detects all collisions between the tool and the workpiece.
- **Rapid Moves:** Only detects collisions during rapid (non-cutting) moves.
- **Cutting Moves:** Only detects collisions during cutting operations.
- **OFF:** Disables all collision detection between the tool and the workpiece.

It can be useful to turn this off because the tool frequently comes into contact with the workpiece during normal machining, which can slow down collision detection. Additionally, this type of collision can often be handled more effectively using [Stock Compare](#) instead.

123 **Collision Step Size**

This option defines the distance between points along the toolpath where collision checks are performed.

Since the simulation cannot check for collisions continuously, it places multiple points along the toolpath and checks for collisions at each one. A smaller step size increases accuracy but may slow down processing, while a larger step size speeds up simulation but might miss some collisions.

123 **Cutter Allowance**

This option defines how far the cutter can penetrate the workpiece before a collision is reported.

Since STL models are made up of triangles with a small margin of error, the cutter may appear to touch the workpiece slightly, leading to false positive collision detections. By setting a value (e.g., 0.1mm), you allow the cutter to move that distance into the workpiece before it is considered a collision. This helps reduce unnecessary collision warnings caused by minor inaccuracies in the model.

123 **Hidden model collisions**

This option controls whether collisions involving hidden models should be detected and reported.

- **ON:** Collisions are checked even for hidden models. This ensures all collisions are detected.
- **OFF:** Collisions for hidden models are ignored. This prevents unnecessary collision reports for models that are hidden.

If a model is hidden only for better visibility but still important for collision detection, this option should remain enabled.

5.3.2.2. Stock Verification Settings

123 **Refine edges**

Enable this to improve the precision of edges in the stock model.

- **Yes:** Enabled
- **No:** Disabled

This option is not available when the new enhancing algorithm is enabled.

123 **Rapid collisions**

Enable this to check for collisions during rapid movement.

- **On (Highlighted in red):** Enabled
- **Off:** Disabled

123 **Stopped spindle**

This option determines what should happen in the simulation when the spindle is not turning (spindle speed is 0).

- **Cut:** Ignore the error and cut the stock material anyway.

- **No cut:** Do not cut the stock material.
 - **Mark collision:** Cut the stock material, but mark the cut red.
-

Tool colors

Enable this to add a distinct color to the machined areas of the stock, corresponding to each tool used.

- **On:** Enabled
 - **Off:** Disabled
-

Quality zoom depth filter

Enable this to limit the options *Zoom window* and *Zoom selection* (in the [Solid](#) menu) to only make a "cut out" to a certain depth in the view direction.

- **On:** Enabled
 - **Off:** Disabled
-

5.3.2.3. Simulation Settings

Maximum Loop Iteration Limit

If a loop is encountered within the NC program being simulated, this setting controls how many loop iterations will be allowed before CIMCO Edit triggers the *Behavior When Limit is Reached* action (below).

Behavior When Limit is Reached

This setting controls what will occur when the *Maximum Loop Iteration Limit* (above) is reached.

- **Ignore the limit**
 - **Break out of the loop**
 - **Prompt for decision**
-

Radius compensation

This setting controls whether radius compensation is ignored or not.

- **Enabled:** Radius compensation is not ignored
 - **Disabled:** Radius compensation is ignored
-

Arc Type

Controls how to interpret the arc center specification.

- **As in G-code:** the arc is interpreted as it is written in the G-code and control settings.

- **Auto-detect:** the system will automatically detect whether the arc moves are absolute or incremental based on a geometrical interpretation.
- **Relative to start:** the arc type is forced to be incremental.
- **Absolute arc center:** the arc type is forced to be absolute.
- **Radius value:** the arc is interpreted using a radius value.

123 Subprogram folder

When simulating an NC program that includes subprograms, CIMCO Edit automatically searches for the subprogram files in the same directory as the main program file. However, if you need to, you can use this option to specify a different folder to search for subprogram files.

5.4. Navigation Tab

This section describes the **Navigation** tab which is located in the docking pane.

During the simulation of an NC program, the Navigation tab offers a well-organized overview (a tree menu) of the program's contents. This feature facilitates quick and effortless pinpointing of corresponding positions in both the NC program and the Navigation tab.

To use Navigation, simply select a keyword in the tree menu to automatically jump to the corresponding keyword in the active NC program. Select any line in the NC program and the nearest keyword in the Navigation tree will be highlighted.

Right-click anywhere in the Navigation pane to either expand or collapse all levels in the tree menu.

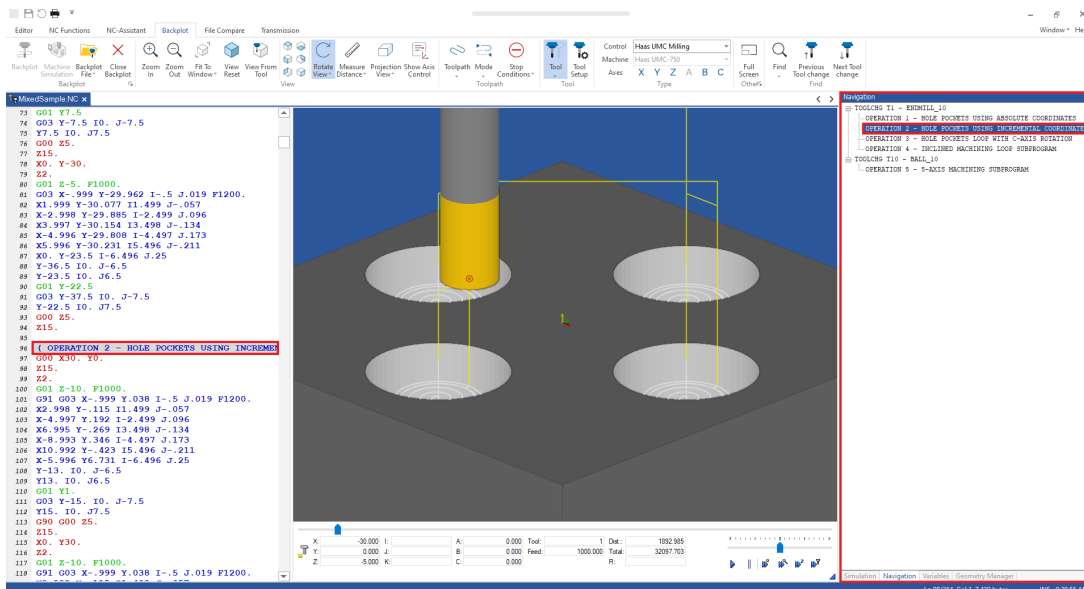

Navigation tab.

5.4.1. Activation and Configuration

To activate Navigation, you must first enable the option 'Scan for navigation information' found within the [Scanning](#) dialog of the Editor Setup. Following that, configure the structure and keywords for scanning in the [Navigation](#) dialog, also located in the Editor Setup.

Please note that the Navigation tab is only visible and updated while simulation (Backplot) is active.

Please refer to the [Navigation](#) dialog for information on how to configure the structure and keywords.

5.5. Variables Tab

This section describes the **Variables** tab which is located in the docking pane.

The Variables tab is divided into two areas: the upper section displays the initial state of variables in your NC program, while the lower section, also referred to as the 'Watch List', shows the current state of variables at any point in the program.

Variables are automatically detected within the active NC program.

You can change the initial values in the upper section without changing the actual NC code. This provides a quick way to test different values. Simply click on a value to change it.

Variables ↑

Filter by used variables

PREDEFINITIONS	VALUE
#10000	0
#10012	0
#10013	0
#10014	0
#10015	0
#10016	0
#10017	0

WATCH	VALUE
#10000	360
#10012	-5
#10013	16
#10014	0.9375
#10015	120
#10016	4
#10017	17

Simulation | Navigation | **Variables** | Geometry Manager

Variables tab.

Options

Filter by used variables

Enable this to only show the variables that are being used within the current NC program.

5.6. Geometry Manager Tab

This section describes the **Geometry Manager** tab which is located in the docking pane.

The Geometry Manger is used for setting up the simulation environment including origin, offsets, workpiece, fixture, machine models, and stock. It is divided into two areas: the upper section shows the elements within the simulation environment, while the lower section lists the properties of the selected element.

Right-click anywhere in the Geometry Manager or on a specific element to see the options available.

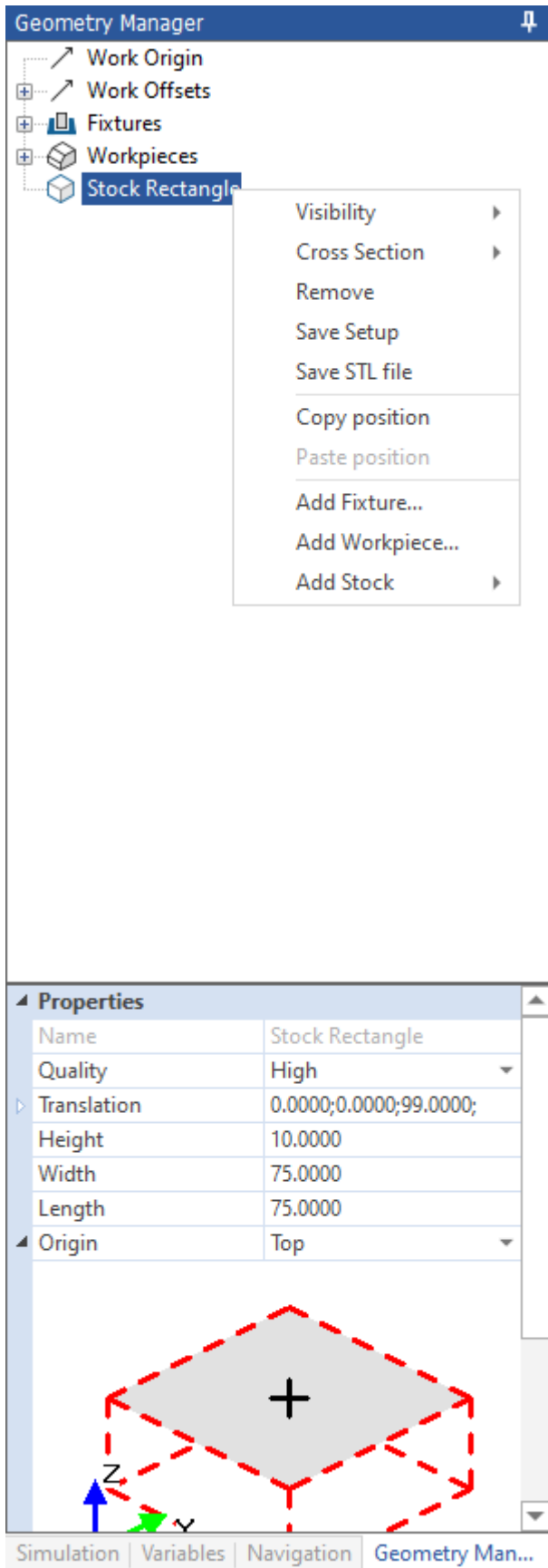

Geometry Manager tab.

Elements

↗ **Work Origin (Machine Origin)**

Specify a position on the machine relative to the machine zero position using the Translation properties.

Properties:

- **Translation:** the X-Y-Z position of the origin
-

 **Work Offsets**

Adjust Work Offsets using the properties below.

Properties:

- **Translation:** the X-Y-Z position
- **Rotation:** the A-B-C rotation

The Head, Table and Base elements below are only available for [Machine Simulation](#).

 **Head**

Shows the head of the machine and its associated axes. Right-click to set visibility. Can be modified using the [Machine Configuration Editor](#)

 **Table**

Shows the table of the machine and its associated axes. Right-click to set visibility. Can be modified using the [Machine Configuration Editor](#)

 **Base**

Shows the base of the machine and its associated axes. Right-click to set visibility. Can be modified using the [Machine Configuration Editor](#)

 **Fixtures / Add Fixture**

Shows the fixtures that have been added to the simulation environment. To add a fixture, right-click anywhere in the Geometry Manager and select the option *Add Fixture*. Locate the corresponding STL file and click *Open*. The fixture will appear below *Fixtures*.

Properties:

- **Translation:** the XYZ position
- **Rotation (Euler):** the Z-X-Z" rotation
- **Color:** the color defined in RGB (0-255)
- **Unit System:** changes the unit of measurement
- **Mount Axis:** Automatic or set to an axis.

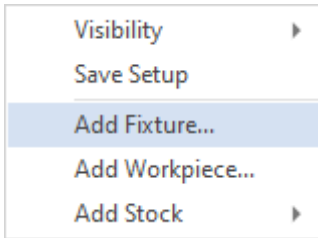

Workpieces / Add Workpiece

Shows the workpieces that have been added to the simulation environment. To add a workpiece, right-click anywhere in the Geometry Manager and select the option *Add Workpiece*. Locate the file and click *Open*. The workpiece will appear below *Workpieces*.

Properties:

- **Translation:** the XYZ position
- **Rotation (Euler):** the Z-X-Z" rotation
- **Color:** the color defined in RGB (0-255)
- **Unit System:** changes the unit of measurement

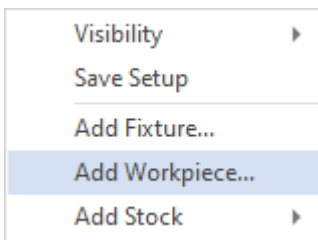

Stock / Add Stock (Rectangle/Cylinder/STL)

Shows the stock that have been added to the simulation environment. You can only add one stock. Right-click in the Geometry Manager and select *Add Stock*.

You will see an additional menu with the following options:

- **STL:** Add an STL model as stock
- **DXF:** Add an DXF model as stock
- **Cylinder:** Add a cylinder shaped stock
- **Box (Dimensions, Min/Max):** Add a rectangular stock

You can also add a stock using the option in the Solid menu under the Backplot tab. See the [Solid](#) menu for detailed descriptions of the different types of stock.

Once added, the stock will appear in the Geometry Manager. Select the stock to configure its properties and to reveal the [True Vision panel](#) in the simulation window:

Properties (general):

- **Quality:** set the quality of the stock model. Higher is more precise, but requires more processing (slower)
- **Translation:** the X-Y-Z position

Properties (STL):

- **Rotation (Euler):** the Z-X-Z" rotation
- **Path:** the path to the .stl file (click the ... on the right, to select a file)
- **Unit System:** changes the unit of measurement

Properties (Cylinder):

- **Diameter:** the diameter of the stock
- **Height:** the height of the stock
- **Axis:** the axis that "points through" the cylinder
- **Origin:** set the position of the origin of the stock

Properties (Dimensions):

- **Height:** the height of the stock
- **Width:** the width of the stock
- **Length:** the length of the stock
- **Origin:** set the position of the origin of the stock

Properties (Min/Max):

- **Lower Corner:** X-Y-Z position
- **Upper Corner:** X-Y-Z position

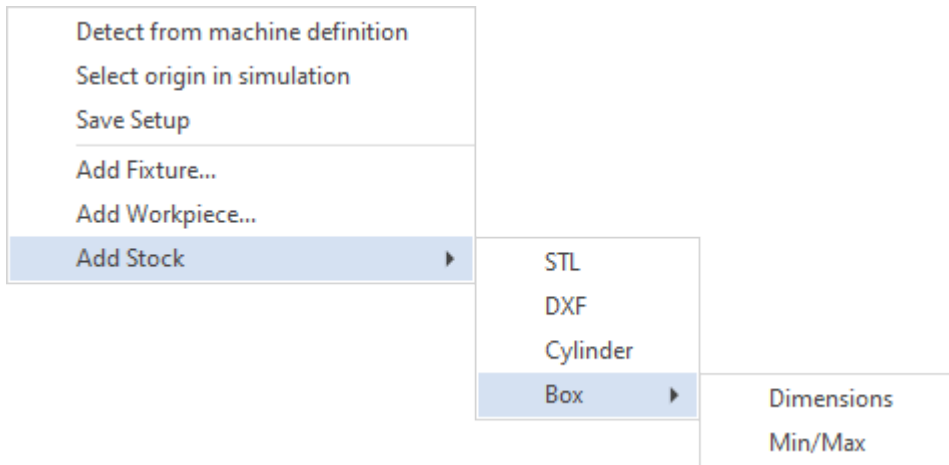

Additional right-click options

— Detect from machine definition

Right-click the *Work Origin* in the Geometry Manager and select this option to copy the XYZ position from the machine definition.

To see the machine definition and its properties, open the [Backplot](#) section in the Editor Setup and then click the button with the machine icon on the right side of the *Machine Setup (4/5-Axis)* dropdown. This will open the [Machine Configuration Editor](#) where you can select the *Base* and then see the *Default Origin* property.

— Select origin in simulation

Right-click the *Work Origin* in the Geometry Manager and select this option to highlight the position of the Work Origin in the simulation. The position is indicated by a white point and the red/green/blue coordinate system axes.

Drag the axes to modify the position of the origin directly in the simulation window.

The XYZ position is displayed in the Workpiece position panel on the right side of the simulation window.

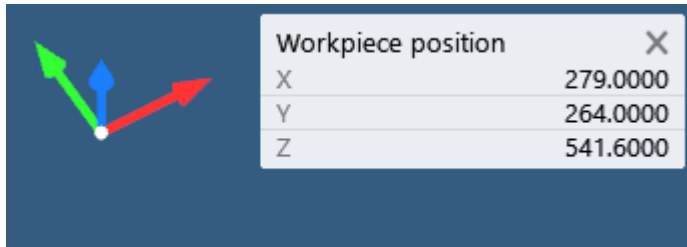

— Visibility

Right-click an element and select *Visibility* to set it to Visible, Hidden, or Transparent.

— Cross Section View

Right-click the stock and select *Cross Section* to slice the stock along an axis. In the simulation view, drag the arrows of the coordinate system element to change the position of the slice.

When activated, the [Cross Section Plane Panel](#) will appear in the simulation window.

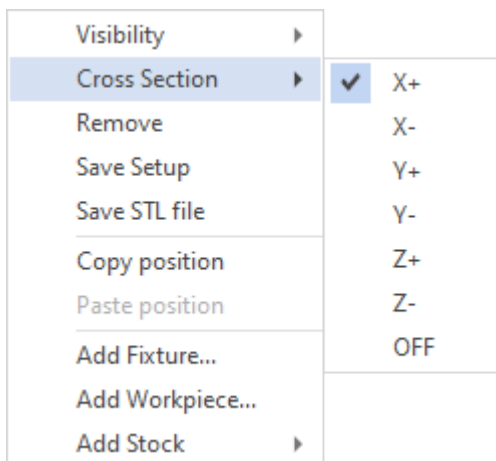

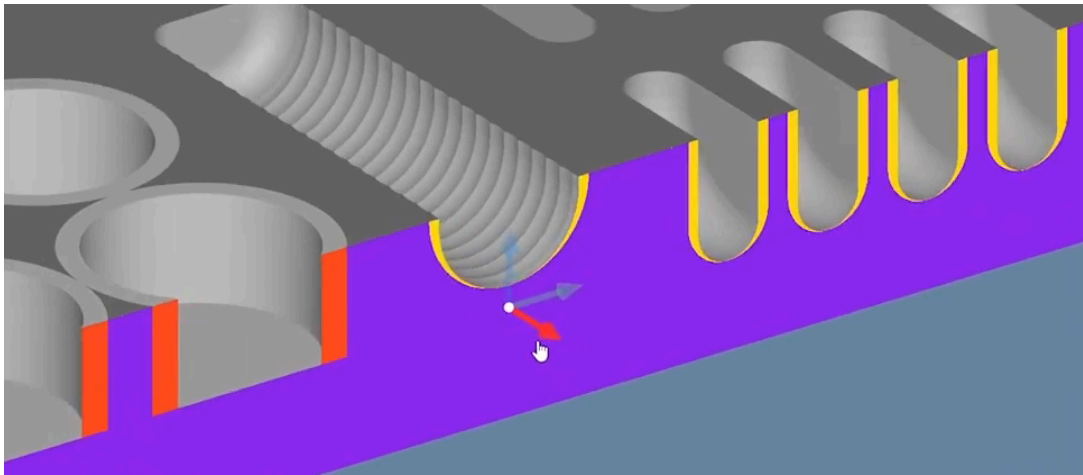

Select *OFF* to disable the Cross Section option.

This option is only available for Fast version simulation.

Remove

Right-click an element and select *Remove* to remove it (if possible).

Regenerate

Right-click the stock and select this option to regenerate (refresh) the solid model of the stock at the current position in the NC program.

This option is only available for Standard version simulation.

Save Setup

Right-click anywhere in the Geometry Manager and select *Save Setup* to save the entire setup.

By default a .setup file will be created in the same location as the NC program you are simulating. The setup file is automatically loaded when starting Backplot / simulation.

Both the loading and saving of the Geometry Manager setup, its elements and tool data are part of the *Scanning* configuration in CIMCO Edit. Please refer to the [Scanning](#) section in the Editor Setup for more information.

Save STL file

Right-click the stock in the Geometry Manager and select *Save STL file* to save the stock, as it is shown at the current position in the NC program / simulation, as an STL file.

Copy Position

Right-click an element and select this to copy its *Translation* and *Rotation* properties.

Paste Position

Right-click an element and select this to paste the *Translation* and *Rotation* properties previously copied.

5.7. Tool Manager

This section describes the Tool Manager which is used for creating and editing tools, and setting up tool libraries.

The Tool Manager is opened in the following way:

1. Select the *Backplot* tab
2. Find the *Tools* menu and click the option [Tool Setup](#)

The main window in the Tool Manager is divided into three areas:

- **Tools in current NC program:** The upper area contains the tools identified in the current NC program (marked with red in the screenshot below).
- **Tool Libraries:** The lower area contains tool libraries (marked with blue below).
- **Tool Preview:** The section on the right contains a preview of the tool currently selected (marked Green below).

The elements and options in each of these areas are described below.

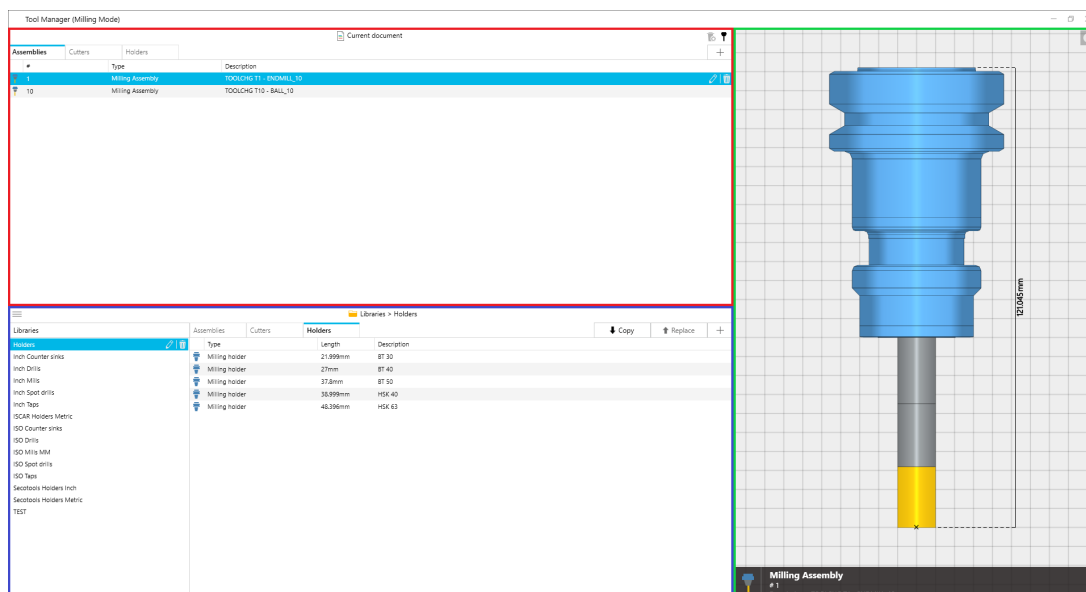

Tool Manager.

Tools in current NC program

Tabs (Assemblies, Cutters and Holders)

Select these tabs to see a list of the assemblies, cutters and holders identified in the current NC program.

- Click an item to select it (notice the Edit and Delete options on the right)
- Double-click an item to edit it
- Right-click an item for additional options (see below)

Please see the following sections for information about how to edit an Assembly, Cutter or Holder:

- [Editing an Assembly](#)
- [Editing a Cutter](#)
- [Editing a Holder](#)

Right-click menu

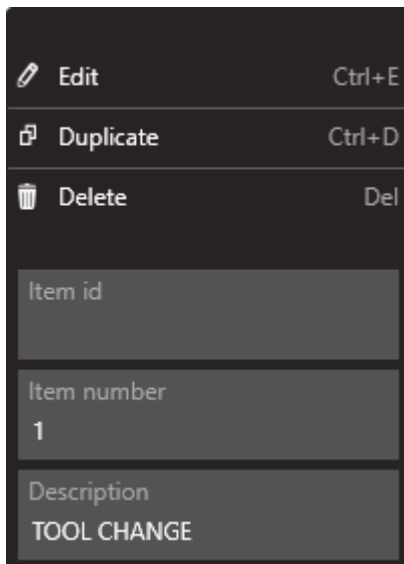

- **Edit:** Edit the selected item
- **Duplicate:** Duplicate the selected item
- **Delete:** Delete the selected item
- **Item id:** Add a custom id to the item
- **Item number:** The number of the item within the NC program
- **Description:** A description of the item

Add Item to Current Document

Create a tool assembly or an individual tool component such as a holder, a drilling tool, a milling tool, insert, etc. to the current NC program.

Please refer to [Create Item](#) for more information.

Hide Preview

Select this option to hide the tool preview section.

Delete Associated Components

Enable this option to also delete associated components such as *holder* and *cutter* when deleting an assembly.

Tool Libraries

Visibility options

Select this menu to hide the entire Tool Libraries section or just the libraries on the left.

Libraries

Displays a list of predefined and custom tool libraries.

- Click a library to select it
- Right-click a library to rename or delete it
- Hover the mouse over a library to see where it is located in the file system. Libraries are always stored under /ToolLibs in the install folder.

When a library is selected, these options are also available as icons on the right side of the selection.

Tabs (Assemblies, Cutters and Holders)

Select these tabs to see a list of the assemblies, cutters and holders available in the currently selected library.

- Click an item to select it (notice the Edit and Delete options on the right)
- Double-click an item to edit it
- Right-click an item for additional options (see below)

Please see the following sections for information about how to edit an Assembly, Cutter or Holder:

- [Editing an Assembly](#)
- [Editing a Cutter](#)
- [Editing a Holder](#)

Right-click menu

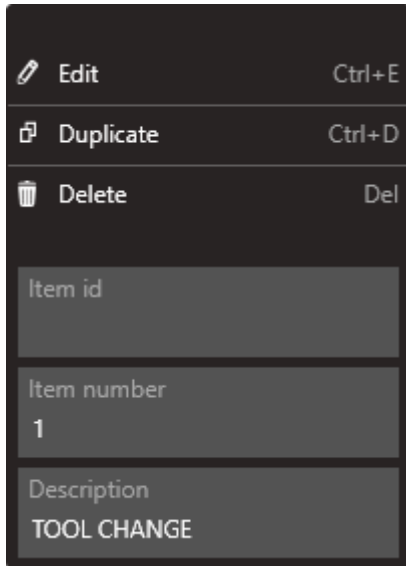

- **Edit:** Edit the selected item
- **Duplicate:** Duplicate the selected item
- **Delete:** Delete the selected item
- **Item id:** Add a custom id to the item
- **Item number:** The number of the item within the NC program
- **Description:** A description of the item

Errors

If the Tool Manger detects and error, the item will show a red triangle  on the right side of the list. Hover the mouse over the triangle to see a description of the error.

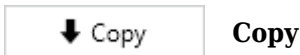

Tools can be copied between a library and the current tool list. The copy button's directional arrow (up or down) will toggle based on the selection made in either the upper list or a library.

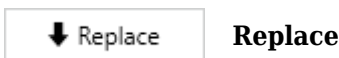

A tool from the library can replace a tool selected in the current list, preserving the original tool number. A tool from the current list can also replace a tool in a library. The direction of the replace button's arrow (up or down) will toggle based on the selection made in either the upper list or a library.



Select this to create a new library or add a tool assembly or an individual tool component such as a holder, a drilling tool, a milling tool, insert, etc to a library.

Please refer to [Create Item](#) for more information.

Tool Preview



Toggle Dark Mode Rendering

Select this item to toggle between dark and light rendering of the tool preview section.

Create Item

The *Create item* dialog appears when creating an assembly, cutter, holder, component, or library.

The dialog is dynamic and will change depending on the type of item you are creating. Some items have several subgroups to help you select the exact item you require. Once selected, the Tool Manager will continue to let you configure the item.

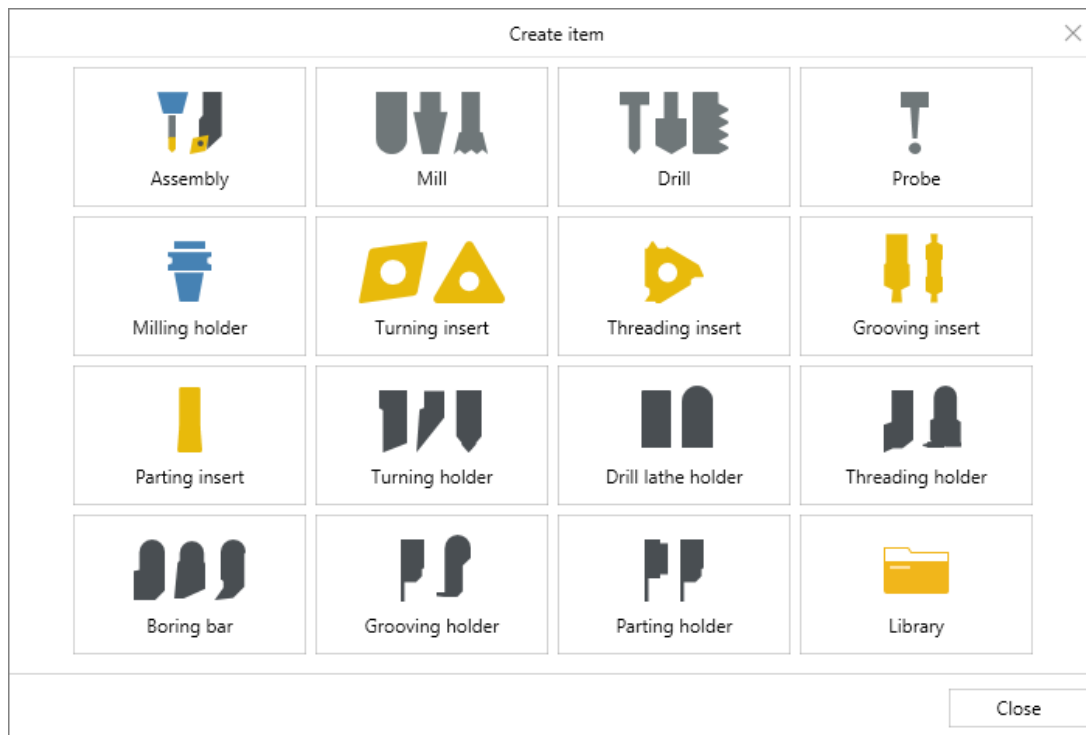

Save and Close

When the simulation (either Backplot or Machine Simulation) is running, CIMCO Edit retains the tool configuration settings (for tools in the current NC program), and any changes made in the Tool Manager will be instantly reflected in the simulation. However, if you close (end) the Backplot or Machine Simulation without saving, these modifications will be lost.

To save changes made in the Tool Manager, follow these steps:

1. Close the Tool Manager (if open)
2. Right-click anywhere in the [Geometry Manager](#)
3. Select the option *Save Setup* (see below)

Close



Select the X to close the Tool Manager. The simulation will update to reflect your changes.

Save (Save Setup)

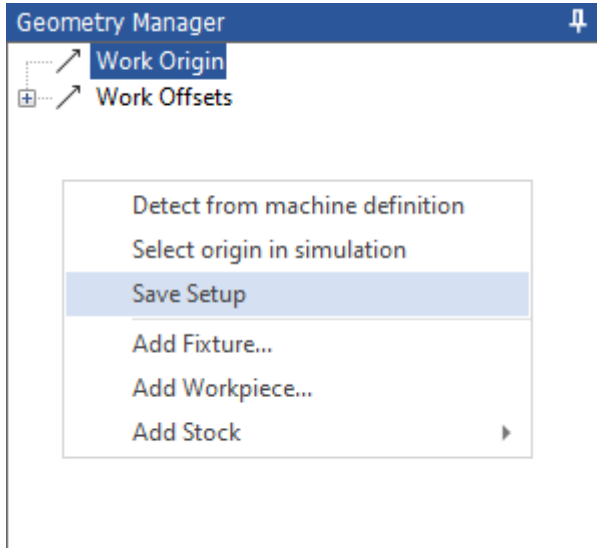

By default, the tool configuration associated with the current NC program will automatically be saved to a .setup file located in the same folder as the NC program file. However, it is also possible to write (insert) the configuration directly into the active NC program itself.

The method of saving depends on how *Scanning* is configured within CIMCO Edit. Both setup and tool configuration data are saved using *Scanning Commands* which are automatically loaded when starting simulation.

Please refer to the [Scanning](#) section in the Editor Setup for more information.

5.7.1. Editing an Assembly

The *Editing assembly* window allows for the configuration of both the cutter and the holder, which constitute the components of an assembly.

Please see [Tool Manager](#) for information on how to select an assembly and open the *Editing assembly* window.

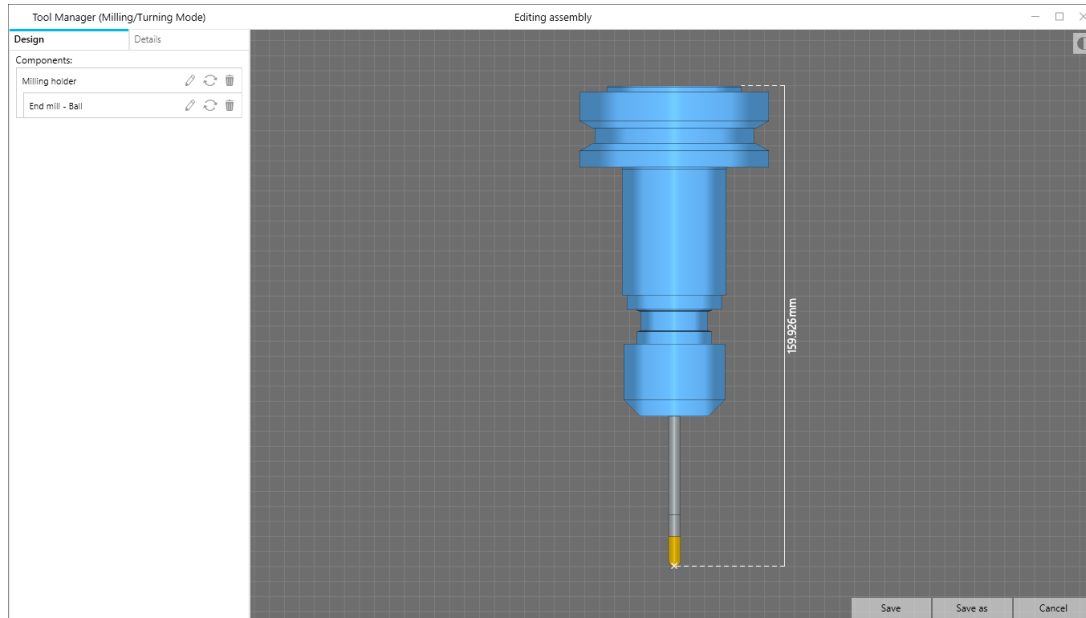

Editing assembly window.

The sidebar on the left contains two tabs; the *Design* and the *Details* tab.

Notice that the *Save*, *Save as*, and *Cancel* buttons are located in the lower-right corner of the assembly preview. You can also use the Escape key to Cancel and return to the previous window.

Design tab

The *Design* tab contains the components that constitute the assembly. The components are nested such that a holder contains a cutter.

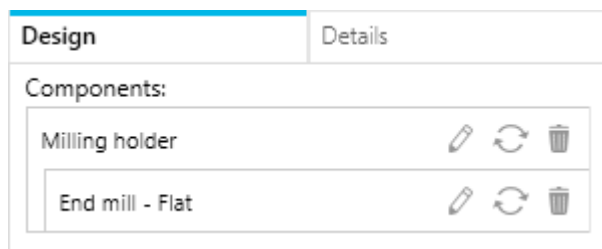

- Hover the mouse over a component to highlight it in the assembly preview on the right.
- Click the left mouse button to select the component
- Double-click a component to edit it

You can also do this directly on the assembly preview.

Edit Component

Select this option to edit the component.

 **Select Component (Replace)**

Select this option to replace the component with another.

 **Remove Component**

Select this option to remove the component. Any nested components will be removed as well.

 **Create New Component**

When creating an empty assembly or if a component has been removed, select this option to add a new component.

Details tab

The *Details* tab contains information about the assembly such as a Description, ID and Item number. This information is also shown in the current list and library.

An assembly also allows you to set the *Cutter point* and *Orientation* depending on the machine setup.

Description

Add a description of the item.

ID

Add a custom id to the item.

Item number

The number of the item within the NC program.

Cutter point (Milling)

The *Cutter point* refers to the actual cutting edge of the tool that engages with the material. It is the part of the tool that performs the cutting action.

- **Center compensation point:**

Adjusts the toolpath for the center of the tool. Useful for tools that do not have a symmetrical cutting profile or when the exact center is crucial for the machining.

- **Tip compensation point:**

Adjusts the toolpath to account for the exact point of the tool that is doing the cutting, which is especially important for tools with a defined tip, such as drills or engraving tools.

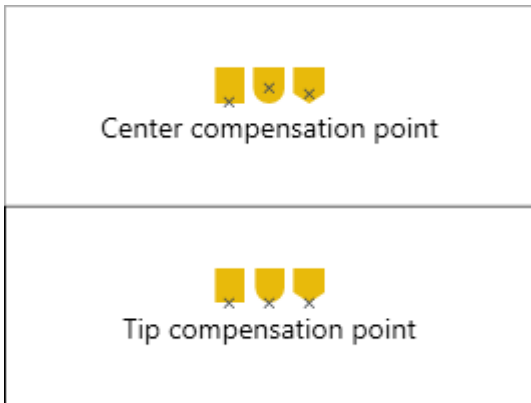

Cutter point (Turning)

The Cutter point refers to the actual cutting edge of the tool that engages with the material. It is the sharp edge of the insert that comes into direct contact with the material to be cut.

The options T2, T6, T1, T0/T9, etc. allows you to define the position of the cutting point.

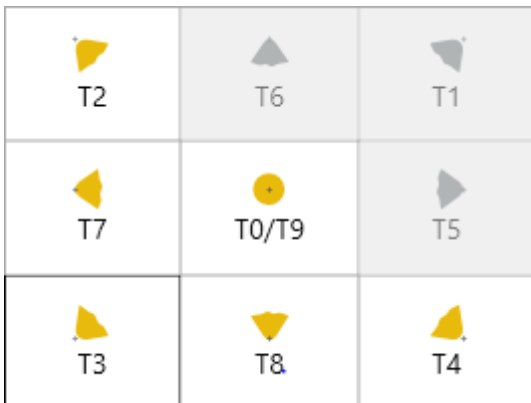

Orientation

Use this to set the orientation of the tool assembly.

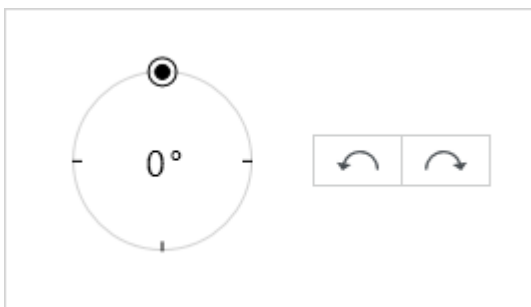

5.7.2. Editing a Cutter

The *Editing cutter* window allows you to define a cutter.

Please see [Tool Manager](#) for information on how to select a cutter and open the *Editing cutter* window.

The term 'Cutter' broadly refers to any component that interacts with the material being worked on. This includes milling tools, turning inserts, and even probes. It is used in the Tool Manager as a general term for the part of the assembly that makes contact with the workpiece.

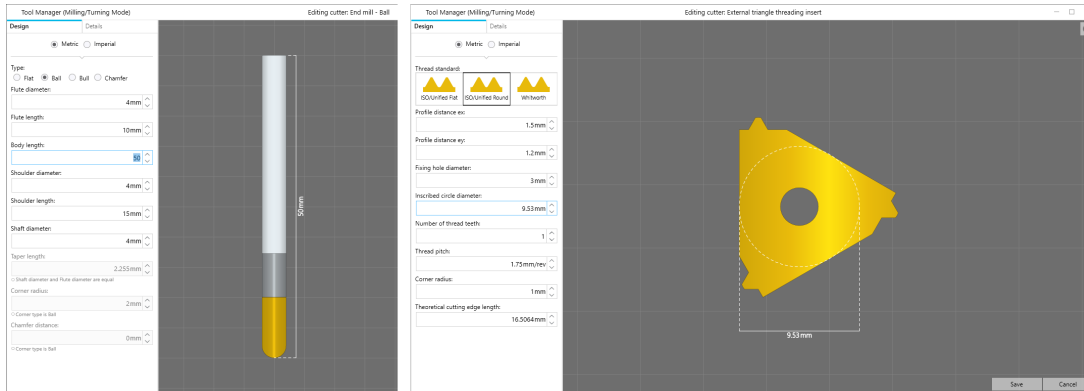

Editing a Cutter (milling tool left, turning insert right).

5.7.2.1. Workflow

As you move the cursor over the different segments of the cutter, the corresponding parameter fields will be highlighted with a blue border. Milling tools normally consists of multiple segments while turning inserts have a single segment.

To select a segment, simply click on it. This will also highlight and activate the related parameter field. You can then directly click on the segment, input your desired value, and press enter to apply the change.

Repeatedly clicking on a segment will cycle through the related parameters, and the measurements will be displayed within the preview for easy reference.

For milling tools and probes, the *Body length* is the total length of the cutter, from the tip to the end where it is held in place. Within this total length, you decide the *Taper length* and *Shoulder length*. Finally, within the Shoulder, you define the *Flute length*. So, you are setting the lengths of each distinct section of the milling tool, starting from the overall tool down to the cutting area.

Every cutter type comes with its own set of options and parameters. Each parameter has a clear description and by using the method above of selecting and cycling through the parameters, it should be both intuitive and straightforward to configure a cutter.

Design tab

Measurement units

Select the unit of measurement you prefer.

Metric Imperial

The following parameters are some of the more common ones for milling tools, however, parameters will vary depending on the specific cutter selected.

123 **Flute diameter**

The diameter of the working part of the tool where the flutes are located.

123 **Flute length**

The Flute length defines how far the flutes go along the body of the tool.

123 **Body length**

The total length of the tool including the taper, shoulder and flutes segments.

123 **Shoulder diameter**

The diameter of the shoulder.

123 **Shoulder length**

The length of the shoulder which also includes the flutes segment.

123 **Shaft diameter**

The diameter of the shaft, which is the part of the tool that is held by the tool holder.

123 **Taper length**

The length of the tapered section of the tool.

123 **Corner radius**

The radius of the tool's tip within the flutes segment.

123 **Chamfer distance**

The length of the chamfered edge at the tool's tip within the flutes segment.

Details tab

Description

Add a description of the item.

ID

Add a custom id to the item.

Filename

Use this field to display an STL model in the simulation instead of the configured cutter.

1. Click the folder icon to locate an STL file
2. The file's path will automatically be inserted in the field

The STL model will only show in the simulation once an STL has been selected for all components in an assembly (for both the holder and cutter).

This feature is intended for visual purposes only. CIMCO Edit will continue to rely on the configured cutter for internal operations like collision detection.

Assembly number

Shows the Assembly item number or the text *Multiple* if the holder is used in more than one assembly.

5.7.3. Editing a Holder

The *Editing holder* window allows you to define a holder.

Please see [Tool Manager](#) for information on how to select a holder and open the *Editing holder* window.

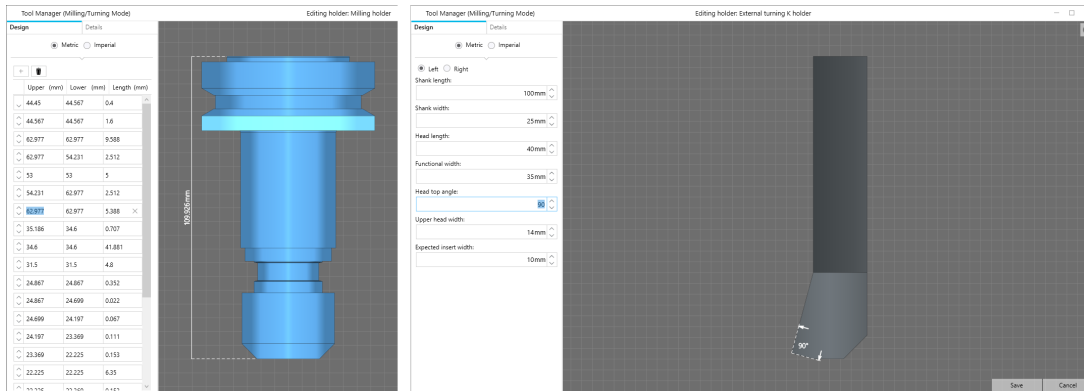

Editing a Holder (milling holder left, turning holder right).

5.7.3.1. Workflow

As you move the cursor over the different segments of the holder, the corresponding *Holder Segment* field (milling) or *Parameter Field(s)* (turning) will be highlighted with a blue border.

To select a segment, simply click on it. This will also highlight and activate the related parameter field. You can then directly click on the segment, input your desired value, and press enter to apply the change.

Repeatedly clicking on a segment will cycle through the related parameters, and the measurements will be displayed within the preview for easy reference.

Milling holders consist of a sequence of holder segments that all have an Upper, Lower and Length parameter. Turning holders, on the other hand, offer a different set of choices and parameters that change based on the type you choose. Every parameter has a clear description and by using the method above of selecting and cycling through the parameters, it should be both intuitive and straightforward to configure a holder.

Design tab (Milling holder)

Measurement units

Select the unit of measurement you prefer.

Metric Imperial

+ Add New Holder Segment

Select this item to add a new holder segment to the bottom of the list.

Delete all Holder Segments

Select this item to delete all of the current holder segments.

Holder Segment

 	60	56	2	
--	----	----	---	---

A holder consists of a sequence of holder segments which make up the full shape. Each segment is defined by the following measurements in either millimeters or inches:

- **Upper:** The width of the top edge
- **Lower:** The width of the bottom edge
- **Length:** The length of the segment from top to bottom

The measurements for the Upper and Lower widths are taken equidistantly from the holder's central axis. For instance, a 60mm width would extend 30mm to the left and 30mm to the right from the midpoint.

- **Up/down arrows:** Use the up/down arrows on the left to move the segment up or down in the list
- **Close icon:** Select this to remove the segment from the list

Design tab (Turning/Lathe holder)

Measurement units

Select the unit of measurement you prefer.

Metric Imperial

Parameter fields

Each type of turning holder has its own set of options and parameters. Parameters are distinctly labeled, and when you select one, the holder preview will visually indicate the part of the holder it corresponds to.

Details tab

Description

Add a description of the item.

ID

Add a custom id to the item.

Filename

Use this field to display an STL model in the simulation instead of the configured holder.

1. Click the folder icon to locate an STL file
2. The file's path will automatically be inserted in the field

The STL model will only show in the simulation once an STL has been selected for all components in an assembly (for both the holder and cutter).

This feature is intended for visual purposes only. CIMCO Edit will continue to rely on the configured holder for internal operations like collision detection.

Assembly number

Shows the Assembly item number or the text *Multiple* if the holder is used in more than one assembly.

5.8. Machine Simulation

Machine Simulation is an add-on for CIMCO Edit 2026, but it is *not* a separate download you need to install. Machine Simulation is already installed as part of CIMCO Edit and its features simply become available once a valid license key has been installed.

5.8.1. Getting started



Machine Simulation is started from the *Machine Simulation* option in the [Backplot](#) menu. This is similar to starting Backplot except it shows the machine and provides some additional options in the simulation window and in the Simulation and Geometry Manager tabs (see below). However, to see a machine in the simulation you first need to follow a couple of steps.

1. Go to the [Machine Models](#) section in the Editor Setup and install the machine you want to simulate.
2. Under the Backplot menu tab, select the Control and Machine from the dropdown in the [Control Type](#) menu. Downloaded machines will show '(Bundled)' after their name.
3. Start Machine Simulation from the [Backplot](#) menu and you should now see the machine in the simulation and its components in the [Geometry Manager](#) tab.

5.8.2. Custom Machines

If the machine you want to simulate is not available, you can use the [Machine Configuration Editor](#), located in the Editor Setup under [Custom Machines](#), to configure your own.

You can also let CIMCO create it for you. We will then create the machine and email you a single .MacBundle file (Machine Bundle) that you can install. The installer simply unpacks the necessary files in the right location within CIMCO Edit and you can then start simulating with the machine.

Please [contact us](#) to learn more about this process.

5.8.3. Exclusive Features

The following outlines the features that become available with Machine Simulation.

5.8.3.1. Simulation Report and Settings

When Machine Simulation is started, the [Simulation Report](#) (located in the Simulation tab) will also include information about collisions and limit errors.

A section with Collision Settings will also be available in the Settings section of the [Simulation tab](#).

5.8.3.2. Geometry Manager

When Machine Simulation is started, the [Geometry Manager](#) will show additional components for the current machine's Head, Table and Base. Expanding any of these will reveal the STL models used to visualize the machine's components.

You can use the visibility option to show or hide components.

5.8.3.3. Stop Conditions

The Stop Conditions option allows you to automatically stop the simulation when specific events occur. This could be a collision, tool change, stopped spindle, exceeded travel limit, etc. The Stop Conditions options can be found and enabled in the [Toolpath menu](#) under the Backplot tab.

5.9. Presentation Viewer (Stand-alone simulation)

The Presentation Viewer allows you to export and share complete simulations from CIMCO Edit for viewing as stand-alone presentations, without requiring CIMCO Edit to be installed. Using the [Save Presentation](#) option, an entire simulation can be saved and viewed in a dedicated viewer application, making it easy to share simulation results with colleagues, customers, or support.

Presentations can be saved either as a simulation file containing only the simulation data, or as a complete presentation bundle that also includes the viewer application. The viewer application only needs to be installed once and can then be used to view multiple simulations exported from CIMCO Edit. Simulation files are compact and well suited for archiving alongside related NC documentation such as setup sheets and tool lists, and for easy distribution.

All options and panels described here exist in CIMCO Edit and are also available in the Presentation Viewer.

The overall application window is divided into five primary areas:

- **Ribbon / Toolbar (Top)**
- **3D Simulation Viewport (Center)**
- **Information Panels (Left)**
- **Axis Control Panel (Right)**
- **Playback & Timeline Controls (Bottom)**

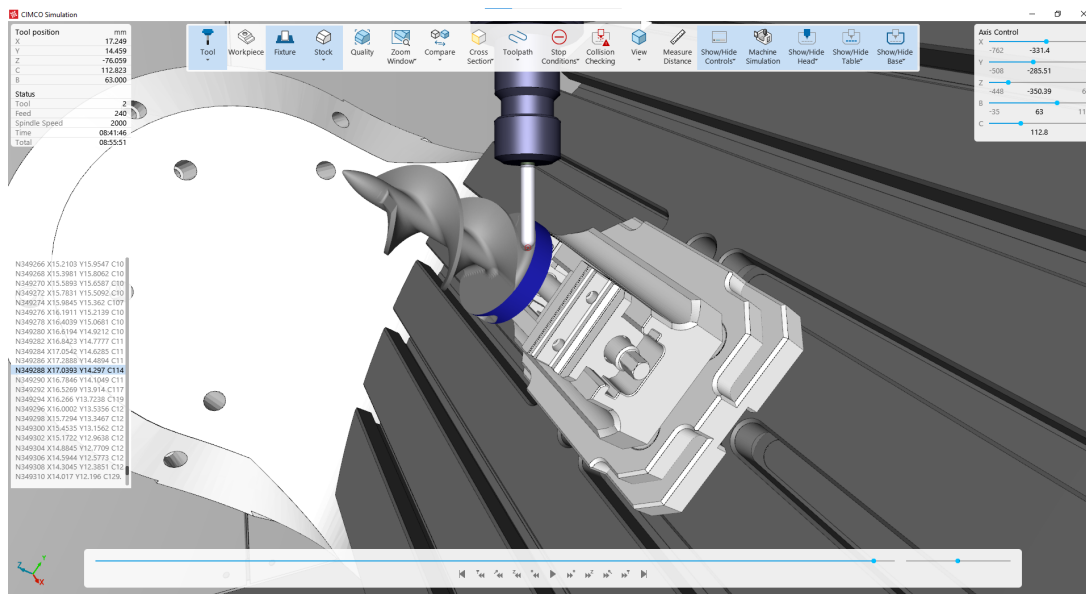

Presentation Viewer application.

5.9.1. Ribbon / Toolbar (Top)

The ribbon bar provides access to all simulation, visualization, and verification tools. Icons are grouped logically and can be enabled or disabled independently.

- **Tool**
Displays the active tool assembly (cutter + holder).

- **Workpiece**
Defines and displays the raw stock geometry.
- **Fixture**
Displays fixtures such as vises, clamps, tombstones, or custom fixturing.
- **Stock**
Controls visibility and visualization of the stock model.
- **Quality**
Opens a side panel that controls surface quality visualization, allowing the user to adjust the quality level from low to high and enable or disable True Vision for a more realistic surface appearance.
- **Zoom Window**
Allows box-zooming into a selected area of the viewport.
- **Compare**
Enables stock comparison view, allowing the current stock state to be compared against a reference stock using color mapping and tolerance settings, equivalent to the Stock Compare option in CIMCO Edit.
- **Cross Section**
Enables the cross-section view, displaying a movable section plane that allows the stock, tool, and workpiece to be dynamically cut and inspected using adjustable plane position and orientation.
- **Toolpath**
Opens the toolpath visualization menu, allowing the toolpath to be shown or hidden and providing multiple visualization and animation modes.
- **Stop Conditions**
Defines simulation stop rules (tool change, block, collision).
- **Collision Checking**
Opens the collision checking panel, enabling real-time detection of collisions between tool, holder, workpiece, stock, and machine components, with configurable checking options and a detailed, time-stamped collision event list.
- **View**
Standard camera views (Top, Front, Isometric, etc.).
- **Measure Distance**
Measures distances directly in the 3D scene.
- **Show / Hide Controls**

Toggles UI overlays.

- **Machine Simulation**

Enables full machine kinematics.

- **Show / Hide Head**

Toggles visibility of the spindle / head.

- **Show / Hide Table**

Toggles visibility of the machine table.

- **Show / Hide Base**

Toggles visibility of the machine base/frame.

5.9.2. 3D Simulation Viewport

The central viewport displays the real-time simulation, showing material removal, tool and holder motion, machine axis movement (X, Y, Z, A/B/C), collision visualization, stock colorization, and cross-section inspection, with interactive mouse orbit, pan, and zoom controls, zoom window selection, and continuous live updates during playback.

5.9.3. Tool Position and Status Panel

Displays the current tool position for linear (X, Y, Z) and optional rotary axes (A, B, C) with units in millimeters and degrees, updating continuously during simulation playback, while also showing machining status information such as active tool number, feedrate, spindle speed, elapsed time, and total machining time for cycle-time validation and presentation overview.

5.9.4. NC Program Panel

Displays the NC program lines, highlighting the currently executed block and scrolling automatically during playback, making it suitable for code walkthroughs, debugging, training, and presentation purposes.

5.9.5. Axis Control Panel

Provides manual axis positioning using sliders and numeric readouts for X, Y, Z, and optional rotary axes (A/B/C), allowing manual inspection, collision checking, demonstration of machine reach, and positioning independent of program execution.

5.9.6. Playback & Timeline Controls

Controls simulation execution using play and pause, step forward and backward, fast forward and rewind, start and end navigation, adjustable playback speed, and a timeline scrubber, with identical behavior in CIMCO Edit Simulation and the Presentation Viewer.

5.10. Supported Controls

5.10.1. Brother

5.10.1.1. Brother Milling

List of G and M-codes for Brother Milling as of CIMCO Edit 2026.01.09

G-Codes	Description
G0	Positioning (rapid traverse)
G1	Linear interpolation (cutting feed)
G2	Circular interpolation CW or helical interpolation CW
G3	Circular interpolation CW or helical interpolation CCW
G4	Dwell
G5_1	AI contour control / Nano smoothing / Smooth interpolation
G10	Programmable data input
G17	XY Plane Selection
G18	XZ Plane Selection
G19	YZ Plane Selection
G20	Input in inch
G21	Input in mm
G28	Automatic return to reference position
G30	2nd, 3rd and 4th reference position return
G40	Tool radius/tool nose radius compensation : cancel, 3-dimensional cutter compensation : cancel
G41	Tool radius/tool nose radius compensation : left, 3-dimensional cutter compensation : left
G42	Tool radius/tool nose radius compensation : right, 3-dimensional cutter compensation : right
G43	Tool length compensation +
G43_4	Tool center point control (type 1)
G43_5	Tool center point control (type 2)
G44	Tool length compensation -
G49	Tool length compensation cancel
G52	Local coordinate system setting
G53	Machine coordinate system setting

G-Codes	Description
G53_1	Tool-axis direction control
G54	Workpiece coordinate system #1
G54_1	Additional workpiece coordinate systems
G54_2	Rotary fixture offset
G55	Workpiece coordinate system #2
G56	Workpiece coordinate system #3
G57	Workpiece coordinate system #4
G58	Workpiece coordinate system #5
G59	Workpiece coordinate system #6
G65	Subprogram call with arguments
G68	3-dimensional coordinate system conversion
G68_2	Tilted working plane command
G69	3-D coordinate conversion OFF
G73	High-Speed Peck Drilling Cycle
G74	Left-Handed Tapping Cycle
G76	Fine Boring Cycle
G77	Canned cycle tapping cycle (synchro mode)
G78	Canned cycle (Reverse tapping cycle) (synchro mode)
G80	Canned cycle cancel, Electronic gear box : synchronization cancellation
G81	Drilling Cycle, Spot Drilling
G82	Drilling Cycle, Counter Boring Cycle
G83	Peck Drilling Cycle
G84	Tapping cycle
G85	Boring cycle 1
G86	Boring cycle 2
G87	Boring cycle 2
G88	Boring cycle 3
G89	Boring cycle 4
G90	Absolute programming
G91	Incremental programming
G92	Work Coordinate Systems Shift Value
G92_1	Workpiece Coordinate System Preset
G94	Feed per minute
G95	Feed per revolution
G98	Canned cycle : return to initial level
G99	Canned cycle : return to R point level
G100	Non-stop automatic tool change
G102	XZ Circular interpolation CW
G103	XZ Circular interpolation CCW

G-Codes	Description
G202	YZ Circular interpolation CW
G203	YZ Circular interpolation CCW
M-Codes	Description
M0	Programmed stop
M1	Optional stop
M2	End of program
M3	Spindle CW
M4	Spindle CCW
M5	Spindle Stop
M6	Tool Change
M8	Coolant ON - Flood coolant
M9	Coolant Off
M30	End of program and reset
M98	Subprogram call
M99	Subprogram end

5.10.2. Centroid

5.10.2.1. Centroid Milling

List of G and M-codes for Centroid Milling as of CIMCO Edit 2026.01.09

G-Codes	Description
G0	Positioning (rapid traverse)
G1	Linear interpolation (cutting feed)
G2	Circular interpolation CW or helical interpolation CW
G3	Circular interpolation CW or helical interpolation CCW
G4	Dwell
G10	Parameter Setting
G17	XY Plane Selection
G18	XZ Plane Selection
G19	YZ Plane Selection
G20	Input in inch
G21	Input in mm
G28	Automatic return to reference position
G30	2nd, 3rd and 4th reference position return
G40	Tool radius/tool nose radius compensation : cancel, 3-dimensional cutter compensation : cancel
G41	Tool radius/tool nose radius compensation : left, 3-dimensional cutter compensation : left
G42	Tool radius/tool nose radius compensation : right, 3-dimensional cutter compensation : right
G43	Tool length compensation +

G-Codes	Description
G43_3	Tool Length Compensation (+) with Axis Tilt Compensation
G43_4	Rotary Tool Center Point (with G43.3) Compensation
G44	Tool length compensation -
G49	Tool length compensation cancel
G52	Local coordinate system setting
G53	Machine coordinate system setting
G54	Workpiece coordinate system #1
G55	Workpiece coordinate system #2
G56	Workpiece coordinate system #3
G57	Workpiece coordinate system #4
G58	Workpiece coordinate system #5
G59	Workpiece coordinate system #6
G65	Subprogram call with arguments
G68	3-dimensional coordinate system conversion
G68_1	3-dimensional coordinate system conversion
G69	3-D coordinate conversion OFF
G73	High-Speed Peck Drilling Cycle
G74	Left-Handed Tapping Cycle
G76	Fine Boring Cycle
G80	Canned cycle cancel, Electronic gear box : synchronization cancellation
G81	Drilling Cycle, Spot Drilling
G82	Drilling Cycle, Counter Boring Cycle
G83	Peck Drilling Cycle
G84	Tapping cycle
G85	Boring cycle 1
G89	Boring cycle 4
G90	Absolute programming
G91	Incremental programming
G92	Work Coordinate Systems Shift Value
G94	Feed per minute
G95	Feed per revolution
G98	Canned cycle : return to initial level
G99	Canned cycle : return to R point level
G117	Rotation of Plane Selection XY
G118	Rotation of Plane Selection ZX
G119	Rotation of Plane Selection YZ
G173	Compound High Speed Peck Drilling
G174	Compound Counter Tapping
G176	Compound Fine Bore Cycle

G-Codes	Description
G180	Compound Canned Cycle Cancel
G181	Compound Drilling and Spot Drilling
G182	Compound Drill with Dwell
G183	Compound Deep Hole Drilling
G184	Compound Tapping
G185	Compound Boring
G189	Compound Boring with Dwell
M-Codes	Description
M0	Programmed stop
M1	Optional stop
M2	End of program
M3	Spindle CW
M4	Spindle CCW
M5	Spindle Stop
M6	Tool Change
M7	Coolant ON - Mist coolant/Coolant thru spindle
M8	Coolant ON - Flood coolant
M9	Coolant Off
M25	Move to Z Home
M30	End of program and reset
M98	Subprogram call
M99	Subprogram end

5.10.2.2. Centroid Turning

List of G and M-codes for Centroid Turning as of CIMCO Edit 2026.01.09

G-Codes	Description
G0	Positioning (rapid traverse)
G1	Linear interpolation (cutting feed)
G2	Circular interpolation CW or helical interpolation CW
G3	Circular interpolation CW or helical interpolation CCW
G4	Dwell
G10	Parameter Setting
G17	XY Plane Selection
G18	XZ Plane Selection
G19	YZ Plane Selection
G20	Input in inch
G21	Input in mm
G28	Automatic return to reference position
G30	2nd, 3rd and 4th reference position return

G-Codes	Description
G32	Constant Lead Thread Cutting
G40	Tool radius/tool nose radius compensation : cancel, 3-dimensional cutter compensation : cancel
G41	Tool radius/tool nose radius compensation : left, 3-dimensional cutter compensation : left
G42	Tool radius/tool nose radius compensation : right, 3-dimensional cutter compensation : right
G52	Offset Local Coordinate System
G53	Rapid Positioning in Machine Coordinates
G54	Workpiece coordinate system #1
G55	Workpiece coordinate system #2
G56	Workpiece coordinate system #3
G57	Workpiece coordinate system #4
G58	Workpiece coordinate system #5
G59	Workpiece coordinate system #6
G65	Subprogram call with arguments
G70	Profile Finishing Cycle
G71	Profile Stock Removal in Turning
G72	Profile Stock Removal in Facing
G73	Profile Path Repeating Cycle
G74	End Face Peck Cutting Cycle
G75	Outside/Inside Diameter Peck Cutting Cycle
G76	Multi-pass Threading Cycle
G80	Canned cycle cancel, Electronic gear box : synchronization cancellation
G83	Peck Drilling Cycle
G84	Tapping cycle
G85	Boring cycle 1
G90	Outside/Inside Diameter Cutting Cycle
G92	Thread Cutting Cycle
G96	Turns on constant surface speed
G97	Cancel constant surface speed
G98	Feed per minute
G99	Feed per revolution
M-Codes	Description
M0	Programmed stop
M1	Optional stop
M2	End of program
M3	Spindle CW
M4	Spindle CCW
M5	Spindle Stop
M6	Tool Change
M7	Coolant ON - Mist coolant/Coolant thru spindle

M-Codes	Description
M8	Coolant ON - Flood coolant
M9	Coolant Off
M30	End of program and reset
M98	Subprogram call
M99	Subprogram end

5.10.3. Delectron

5.10.3.1. Delectron Milling

List of G and M-codes for Delectron Milling as of CIMCO Edit 2026.01.09

G-Codes	Description
G0	Positioning (rapid traverse)
G1	Linear interpolation (cutting feed)
G2	Circular interpolation CW or helical interpolation CW
G3	Circular interpolation CW or helical interpolation CCW
G4	Dwell
G25	Contouring plane selection
G26	Subprogram end
G40	Tool radius/tool nose radius compensation : cancel, 3-dimensional cutter compensation : cancel
G41	Tool radius/tool nose radius compensation : left, 3-dimensional cutter compensation : left
G42	Tool radius/tool nose radius compensation : right, 3-dimensional cutter compensation : right
G43	Tool length compensation +
G44	Tool length compensation -
G45	Suspend tool length compensation
G53	Suspend the corrections introduced by supplementary origins and tool length
G54	Restoring of corrections due to supplementary origins and tool length
G55	Cancel mirroring on the working plane
G56	Enable mirroring on the working plane
G90	Absolute programming
G91	Incremental programming
G94	Feed per minute
G95	Feed per revolution
G116	Roto-translate a machining
G117	Rotating tool center point
G118	RTCP for rotary/tilting tables
G800	Canned cycles
G801	Positioning macros
G802	Machining macros

M-Codes	Description
M0	Programmed stop
M1	Optional stop
M2	End of program
M3	Spindle CW
M4	Spindle CCW
M5	Spindle Stop
M6	Tool Change
M8	Coolant ON - Flood coolant
M9	Coolant Off
M19	Spindle orientation
M30	End of program and reset

5.10.4. Fagor

5.10.4.1. Fagor Milling

List of G and M-codes for Fagor Milling as of CIMCO Edit 2026.01.09

G-Codes	Description
G0	Rapid Motion Positioning
G1	Linear Interpolation Motion
G2	Circular Interpolation Motion CW
G3	Circular Interpolation Motion CCW
G4	Dwell
G5	Controlled corner rounding (modal)
G6	Arc center in absolute coordinates (no-modal)
G7	Square corner (modal)
G8	Arc tangent to previous path
G9	Arc defined by three points
G10	Mirror image cancellation
G11	Mirror image on the first axis of the channel
G12	Mirror image on the second axis of the channel
G13	Mirror image on the third axis of the channel
G14	Mirror image in the programmed directions
G17	XY Plane Selection
G18	XZ Plane Selection
G19	YZ Plane Selection
G20	Main plane by two directions and longitudinal axis
G30	Polar origin preset
G31	Temporary polar origin shift to the center of arc

G-Codes	Description
G36	Corner rounding, radius blend
G37	Tangential entry
G38	Tangential exit
G39	Corner chamfering
G40	Tool nose compensation cancel
G41	Tool Nose Compensation (TNC) Left
G42	Tool Nose Compensation (TNC) Right
G51	Smoothing Mode On
G53	Zero offset cancellation
G54	Select Work Coordinate System #1
G55	Select Work Coordinate System #2
G56	Select Work Coordinate System #3
G57	Select Work Coordinate System #4
G58	Select Work Coordinate System #5
G59	Select Work Coordinate System #6
G60	Square corner (no-modal)
G61	Controlled corner rounding (no-modal)
G63	Rigid tapping
G70	Select Inches
G71	Select Metric
G72	Scaling factor
G73	Pattern rotation
G74	Machine reference zero (home) search
G80	Canned Cycle Cancel
G81	Drilling canned cycle
G82	Drilling canned cycle with variable peck
G83	Deep-hole drilling canned cycle with constant peck
G84	Tapping cycle
G85	Reaming canned cycle
G86	Boring canned cycle
G87	Rectangular pocket canned cycle
G88	Circular pocket canned cycle
G90	Absolute programming
G91	Incremental programming
G92	Set Local Work Coordinate System
G93	Machining time in seconds
G94	Feed Per Minute Mode
G95	Feed Per Revolution
G96	Constant surface speed

G-Codes	Description
G97	Constant turning speed
G98	Canned cycle : return to initial level
G99	Canned cycle : return to R point level
G151	Programming in diameters
G152	Programming in radius
G158	Incremental zero offset
G159	Additional absolute zero offsets
G160	Multiple machining in straight line
G161	Multiple machining in rectangular pattern
G162	Multiple machining in grid pattern
G163	Multiple machining in a full circle
G164	Multiple machining in arc pattern
G165	Multiple machining in a chord pattern
G192	Programming the turning speed limit
G210	Bore milling canned cycle
G211	Inside thread milling cycle
G212	Outside thread milling cycle
G261	Arc center in absolute coordinates (modal)
G262	Arc center referred to starting point
G263	Arc radius programming
G501	Activates HSC on, defaulting to Surface mode (recommended) and allowing parameter overrides

M-Codes	Description
M0	Programmed stop
M1	Conditional program stop
M2	End of program
M3	Start the spindle clockwise
M4	Start the spindle counterclockwise
M5	Stop the spindle
M6	Tool change
M17	End of a global or local subroutine
M29	End of a global or local subroutine
M30	End of program and reset

5.10.4.2. Fagor Turning

List of G and M-codes for Fagor Turning as of CIMCO Edit 2026.01.09

G-Codes	Description
G0	Rapid Motion Positioning
G1	Linear Interpolation Motion
G2	Circular Interpolation Motion CW

G-Codes	Description
G3	Circular Interpolation Motion CCW
G4	Dwell
G5	Controlled corner rounding (modal)
G6	Arc center in absolute coordinates (no-modal)
G7	Square corner (modal)
G8	Arc tangent to previous path
G9	Arc defined by three points
G10	Mirror image cancellation
G11	Mirror image on the first axis of the channel
G12	Mirror image on the second axis of the channel
G13	Mirror image on the third axis of the channel
G14	Mirror image in the programmed directions
G17	XY Plane Selection
G18	XZ Plane Selection
G19	YZ Plane Selection
G30	Polar origin preset
G31	Temporary polar origin shift to the center of arc
G33	Electronic threading with constant pitch
G34	Electronic threading with variable pitch
G36	Corner rounding, radius blend
G37	Tangential entry
G38	Tangential exit
G39	Corner chamfering
G40	Tool nose compensation cancel
G41	Tool Nose Compensation (TNC) Left
G42	Tool Nose Compensation (TNC) Right
G51	Smoothing Mode On
G53	Zero offset cancellation
G54	Select Work Coordinate System #1
G55	Select Work Coordinate System #2
G56	Select Work Coordinate System #3
G57	Select Work Coordinate System #4
G58	Select Work Coordinate System #5
G59	Select Work Coordinate System #6
G60	Square corner (no-modal)
G61	Controlled corner rounding (no-modal)
G63	Rigid tapping
G66	Pattern repeat canned cycle
G68	Stock removal cycle along X axis

G-Codes	Description
G69	Stock removal canned cycle along Z axis
G70	Select Inches
G71	Select Metric
G72	Scaling factor
G73	Pattern rotation
G74	Machine reference zero (home) search
G80	Canned Cycle Cancel
G81	Turning canned cycle with straight sections
G82	Facing canned cycle with straight sections
G83	Axial drilling and tapping canned cycle
G84	Turning canned cycle with arcs
G85	Facing canned cycle with arcs
G86	Longitudinal threading canned cycle
G87	Face threading canned cycle
G88	Grooving canned cycle along the X axis
G89	Grooving canned cycle along the Z axis
G90	Absolute programming
G91	Incremental programming
G92	Set Local Work Coordinate System
G93	Machining time in seconds
G94	Feed Per Minute Mode
G95	Feed Per Revolution
G96	Constant surface speed
G97	Constant turning speed
G151	Programming in diameters
G152	Programming in radius
G158	Incremental zero offset
G159	Additional absolute zero offsets
G192	Programming the turning speed limit
G261	Arc center in absolute coordinates (modal)
G262	Arc center referred to starting point
G263	Arc radius programming
M-Codes	Description
M0	Programmed stop
M1	Conditional program stop
M2	End of program
M3	Start the spindle clockwise
M4	Start the spindle counterclockwise
M5	Stop the spindle

M-Codes	Description
M6	Tool change
M17	End of a global or local subroutine
M29	End of a global or local subroutine
M30	End of program and reset

5.10.5. Fanuc

5.10.5.1. Fanuc Milling

List of G and M-codes for Fanuc Milling as of CIMCO Edit 2026.01.09

G-Codes	Description
G0	Positioning (rapid traverse)
G1	Linear interpolation (cutting feed)
G2	Circular interpolation CW or helical interpolation CW
G3	Circular interpolation CW or helical interpolation CCW
G4	Dwell
G5	AI contour control (high-precision contour control compatible command), High-speed cycle machining, High-speed binary program operation
G5_1	AI contour control / Nano smoothing / Smooth interpolation
G10	Programmable data input
G12_1	Polar coordinate interpolation mode
G13_1	Polar coordinate interpolation cancel mode
G15	Polar coordinates command cancel
G16	Polar coordinates command
G17	XY Plane Selection
G18	XZ Plane Selection
G19	YZ Plane Selection
G20	Input in inch
G21	Input in mm
G28	Automatic return to reference position
G30	2nd, 3rd and 4th reference position return
G40	Tool radius/tool nose radius compensation : cancel, 3-dimensional cutter compensation : cancel
G41	Tool radius/tool nose radius compensation : left, 3-dimensional cutter compensation : left
G42	Tool radius/tool nose radius compensation : right, 3-dimensional cutter compensation : right
G43	Tool length compensation +
G43_4	Tool center point control (type 1)
G43_5	Tool center point control (type 2)
G44	Tool length compensation -
G49	Tool length compensation cancel

G-Codes	Description
G50_1	Programmable mirror image cancel
G51_1	Programmable mirror image
G52	Local coordinate system setting
G53	Machine coordinate system setting
G53_1	Tool-axis direction control
G53_6	Tool center point retention type tool axis direction control
G54	Workpiece coordinate system #1
G54_1	Additional workpiece coordinate systems
G54_2	Dynamic offsetting
G54_4	Workpiece setting error compensation
G55	Workpiece coordinate system #2
G56	Workpiece coordinate system #3
G57	Workpiece coordinate system #4
G58	Workpiece coordinate system #5
G59	Workpiece coordinate system #6
G65	Subprogram call with arguments
G66	Modal Subprogram set with arguments
G66_1	Modal Subprogram set with arguments
G67	Cancel modal subprogram call
G68	3-dimensional coordinate system conversion
G68_1	3-dimensional coordinate system conversion
G68_2	Tilted working plane command
G68_3	Tilted working plane command by tool axis direction
G68_4	Tilted working plane command (incremental multiple command)
G69	3-D coordinate conversion OFF
G73	High-Speed Peck Drilling Cycle
G74	Left-Handed Tapping Cycle
G76	Fine Boring Cycle
G80	Canned cycle cancel, Electronic gear box : synchronization cancellation
G81	Drilling Cycle, Spot Drilling
G82	Drilling Cycle, Counter Boring Cycle
G83	Peck Drilling Cycle
G84	Tapping cycle
G85	Boring cycle 1
G86	Boring cycle 2
G87	Boring cycle 2
G88	Boring cycle 3
G89	Boring cycle 4
G90	Absolute programming

G-Codes	Description
G91	Incremental programming
G92_1	Workpiece Coordinate System Preset
G92	Work Coordinate Systems Shift Value
G94	Feed per minute
G95	Feed per revolution
G98	Canned cycle : return to initial level
G99	Canned cycle : return to R point level
G103	Toolbreakage check macro
G120	High speed mode cancel
G121	High speed mode
G130	High speed mode cancel
G131	High speed mode
G320	Specifying Automatic Centering/Automatic Measurement
G325	Automatic Tool Breakage Detection
G400	Yasda machine: measuring function
G500	Yasda machine: measuring function
G950	Machining levels setup

M-Codes	Description
M0	Programmed stop
M1	Optional stop
M2	End of program
M3	Spindle CW
M4	Spindle CCW
M5	Spindle Stop
M6	Tool Change
M8	Coolant ON - Flood coolant
M9	Coolant Off
M13	Spindle ON clockwise/Coolant ON
M14	Spindle ON counterclockwise/Coolant ON
M30	End of program and reset
M31	??
M98	Subprogram call
M99	Subprogram end
M198	External subprogram call

5.10.5.2. Fanuc Turning

G and M-codes for Fanuc Turning as of CIMCO Edit 2026.01.09

G-Codes	System A	System B	System C
G0	Rapid Motion Positioning	Rapid Motion Positioning	Rapid Motion Positioning

G-Codes	System A	System B	System C
G1	Linear Interpolation Motion	Linear Interpolation Motion	Linear Interpolation Motion
G2	Circular Interpolation Motion CW	Circular Interpolation Motion CW	Circular Interpolation Motion CW
G3	Circular Interpolation Motion CCW	Circular Interpolation Motion CCW	Circular Interpolation Motion CCW
G4	Dwell	Dwell	Dwell
G7.1	(G107) Cylindrical interpolation	(G107) Cylindrical interpolation	(G107) Cylindrical interpolation
G10	Programmable data input	Programmable data input	Programmable data input
G12.1	Polar coordinate interpolation mode	Polar coordinate interpolation mode	Polar coordinate interpolation mode
G13.1	Polar coordinate interpolation cancel mode	Polar coordinate interpolation cancel mode	Polar coordinate interpolation cancel mode
G17	XY Plane Selection	XY Plane Selection	XY Plane Selection
G18	XZ Plane Selection	XZ Plane Selection	XZ Plane Selection
G19	YZ Plane Selection	YZ Plane Selection	YZ Plane Selection
G20	Select Inches	Select Inches	O.D./I.D. Turning Cycle
G21	Select Metric	Select Metric	Threading Cycle
G24	-	-	End Facing Cycle
G28	Return To Machine Zero Point	Return To Machine Zero Point	Return To Machine Zero Point
G28_2	Return To Machine Zero Point	Return To Machine Zero Point	Return To Machine Zero Point
G30	2nd, 3rd and 4th reference position return	2nd, 3rd and 4th reference position return	2nd, 3rd and 4th reference position return
G30_2	2nd, 3rd and 4th reference position return	2nd, 3rd and 4th reference position return	2nd, 3rd and 4th reference position return
G32	Thread Cutting	-	-
G33	-	Thread Cutting	Thread Cutting
G40	Tool nose compensation cancel	Tool nose compensation cancel	Tool nose compensation cancel
G41	Tool Nose Compensation (TNC) Left	Tool Nose Compensation (TNC) Left	Tool Nose Compensation (TNC) Left
G42	Tool Nose Compensation (TNC) Right	Tool Nose Compensation (TNC) Right	Tool Nose Compensation (TNC) Right
G43	Tool length compensation +	Tool length compensation +	Tool length compensation +
G43_4	Tool center point control (type 1)	Tool center point control (type 1)	Tool center point control (type 1)
G44	Tool length compensation -	Tool length compensation -	Tool length compensation -
G49	Tool length compensation cancel	Tool length compensation cancel	Tool length compensation cancel
G49_1	Tool length compensation cancel	Tool length compensation cancel	Tool length compensation cancel
G50_1	Programmable mirror image cancel	Programmable mirror image cancel	Programmable mirror image cancel
G50	Spindle Speed Maximum RPM Limit	Scaling cancel	Scaling cancel

G-Codes	System A	System B	System C
G51_1	Programmable mirror image	Programmable mirror image	Programmable mirror image
G51	-	Scaling	Scaling
G52	Set Local Work Coordinate System	Set Local Work Coordinate System	Set Local Work Coordinate System
G53	Machine coordinate system setting	Machine coordinate system setting	Machine coordinate system setting
G53_1	Tool-axis direction control	Tool-axis direction control	Tool-axis direction control
G54	Select Work Coordinate System #1	Select Work Coordinate System #1	Select Work Coordinate System #1
G54_1	Additional workpiece coordinate systems	Additional workpiece coordinate systems	Additional workpiece coordinate systems
G55	Select Work Coordinate System #2	Select Work Coordinate System #2	Select Work Coordinate System #2
G56	Select Work Coordinate System #3	Select Work Coordinate System #3	Select Work Coordinate System #3
G57	Select Work Coordinate System #4	Select Work Coordinate System #4	Select Work Coordinate System #4
G58	Select Work Coordinate System #5	Select Work Coordinate System #5	Select Work Coordinate System #5
G59	Select Work Coordinate System #6	Select Work Coordinate System #6	Select Work Coordinate System #6
G65	Subprogram call with arguments	Subprogram call with arguments	Subprogram call with arguments
G68_2	Tilted working plane command	Tilted working plane command	Tilted working plane command
G69_1	3-D coordinate conversion OFF	3-D coordinate conversion OFF	3-D coordinate conversion OFF
G70	Finishing Cycle	Finishing Cycle	Select Inches
G71	O.D./I.D. Stock Removal Cycle	O.D./I.D. Stock Removal Cycle	Select Metric
G72	End Face Stock Removal Cycle	End Face Stock Removal Cycle	Finishing Cycle
G73	Pattern Repeating	Pattern Repeating	O.D./I.D. Stock Removal Cycle
G74	End Face Grooving Cycle	End Face Grooving Cycle	End Face Stock Removal Cycle
G75	O.D./I.D. Grooving Cycle	O.D./I.D. Grooving Cycle	Pattern Repeating
G76	Threading Cycle, Multiple Pass	Threading Cycle, Multiple Pass	End Face Grooving Cycle
G77	-	O.D./I.D. Turning Cycle	O.D./I.D. Grooving Cycle
G78	-	Threading Cycle	Threading Cycle, Multiple Pass
G79	-	End Facing Cycle	-
G80	Canned Cycle Cancel	Canned Cycle Cancel	Canned Cycle Cancel
G81	Drilling Cycle, Spot Drilling	Drilling Cycle, Spot Drilling	Drilling Cycle, Spot Drilling
G82	Drilling Cycle, Counter Boring Cycle	Drilling Cycle, Counter Boring Cycle	Drilling Cycle, Counter Boring Cycle
G83	Peck Drilling Cycle	Peck Drilling Cycle	Peck Drilling Cycle
G83.5	Front high-speed peck drilling cycle	Front high-speed peck drilling cycle	Front high-speed peck drilling cycle
G83.6	Front high-speed peck drilling cycle	Front high-speed peck drilling cycle	Front high-speed peck drilling cycle

G-Codes	System A	System B	System C
G84	Tapping cycle	Tapping cycle	Tapping cycle
G85	Boring Cycle Face	Boring Cycle Face	Boring Cycle Face
G87	Drilling Cycle Side	Drilling Cycle Side	Drilling Cycle Side
G87.5	Side high-speed peck drilling cycle	Side high-speed peck drilling cycle	Side high-speed peck drilling cycle
G87.6	Side high-speed peck drilling cycle	Side high-speed peck drilling cycle	Side high-speed peck drilling cycle
G88	Tapping Cycle Side	Tapping Cycle Side	Tapping Cycle Side
G89	Bore In, Dwell, Bore Out Canned Cycle	Bore In, Dwell, Bore Out Canned Cycle	Bore In, Dwell, Bore Out Canned Cycle
G90	O.D./I.D. Turning Cycle	Absolute programming	Absolute programming
G91	-	Incremental programming	Incremental programming
G92	Threading Cycle	Spindle Speed Maximum RPM Limit	Spindle Speed Maximum RPM Limit
G94	End Facing Cycle	Feed Per Minute Mode	Feed Per Minute Mode
G95	-	Feed Per Revolution	Feed Per Revolution
G96	Turns on constant surface speed	Turns on constant surface speed	Turns on constant surface speed
G97	Cancels constant surface speed	Cancels constant surface speed	Cancels constant surface speed
G98	Feed Per Minute Mode	Canned cycle : return to initial level	Canned cycle : return to initial level
G99	Feed Per Revolution	Canned cycle : return to R point level	Canned cycle : return to R point level
G107	(G107) Cylindrical interpolation	(G107) Cylindrical interpolation	(G107) Cylindrical interpolation
G112	Polar coordinate interpolation mode	Polar coordinate interpolation mode	Polar coordinate interpolation mode
G113	Polar coordinate interpolation cancel mode	Polar coordinate interpolation cancel mode	Polar coordinate interpolation cancel mode
M-Codes	System A	System B	System C
M0	Programmed stop	Programmed stop	Programmed stop
M1	Optional stop	Optional stop	Optional stop
M2	End of program	End of program	End of program
M3	Spindle CW	Spindle CW	Spindle CW
M4	Spindle CCW	Spindle CCW	Spindle CCW
M5	Spindle Stop	Spindle Stop	Spindle Stop
M6	Tool Change	Tool Change	Tool Change
M8	Coolant On	Coolant On	Coolant On
M9	Coolant Off	Coolant Off	Coolant Off
M10	Main spindle clamp	Main spindle clamp	Main spindle clamp
M11	Main spindle unclamp	Main spindle unclamp	Main spindle unclamp
M13	Spindle ON clockwise/Coolant ON	Spindle ON clockwise/Coolant ON	Spindle ON clockwise/Coolant ON

M-Codes	System A	System B	System C
M14	Spindle ON counterclockwise/Coolant ON	Spindle ON counterclockwise/Coolant ON	Spindle ON counterclockwise/Coolant ON
M30	End of program and reset	End of program and reset	End of program and reset
M83	Mill tool spindle forward	Mill tool spindle forward	Mill tool spindle forward
M84	Mill tool spindle reverse	Mill tool spindle reverse	Mill tool spindle reverse
M85	Mill tool spindle stop	Mill tool spindle stop	Mill tool spindle stop
M98	Subprogram call	Subprogram call	Subprogram call
M99	Subprogram end	Subprogram end	Subprogram end
M198	External subprogram call	External subprogram call	External subprogram call
M199	Subprogram end	Subprogram end	Subprogram end
M203	Mill tool spindle forward	Mill tool spindle forward	Mill tool spindle forward
M204	Mill tool spindle reverse	Mill tool spindle reverse	Mill tool spindle reverse
M205	Mill tool spindle stop	Mill tool spindle stop	Mill tool spindle stop
M210	Sub spindle clamp	Sub spindle clamp	Sub spindle clamp
M211	Sub spindle unclamp	Sub spindle unclamp	Sub spindle unclamp
M329	Rigid threading with heads	Rigid threading with heads	Rigid threading with heads

5.10.5.3. Fanuc MX Turning

List of G and M-codes for Fanuc MX Turning as of CIMCO Edit 2026.01.09

G-Codes	Description
G0	Rapid Motion Positioning
G1	Linear Interpolation Motion
G2	Circular Interpolation Motion CW
G3	Circular Interpolation Motion CCW
G4	Dwell
G7.1	(G107) Cylindrical interpolation
G10	Programmable data input
G12.1	Polar coordinate interpolation mode
G13.1	Polar coordinate interpolation cancel mode
G17	XY Plane Selection
G18	XZ Plane Selection
G19	YZ Plane Selection
G28	Return To Machine Zero Point
G30	2nd, 3rd and 4th reference position return
G40	Tool nose compensation cancel
G41	Tool Nose Compensation (TNC) Left
G42	Tool Nose Compensation (TNC) Right
G50_1	Programmable mirror image cancel
G51_1	Programmable mirror image

G-Codes	Description
G52	Set Local Work Coordinate System
G53	Machine coordinate system setting
G53_1	Tool-axis direction control
G54	Select Work Coordinate System #1
G54_1	Additional workpiece coordinate systems
G55	Select Work Coordinate System #2
G56	Select Work Coordinate System #3
G57	Select Work Coordinate System #4
G58	Select Work Coordinate System #5
G59	Select Work Coordinate System #6
G65	Subprogram call with arguments
G68_2	Tilted working plane command
G80	Canned Cycle Cancel
G81	Drilling Cycle, Spot Drilling
G82	Drilling Cycle, Counter Boring Cycle
G83	Peck Drilling Cycle
G83.5	Front high-speed peck drilling cycle
G83.6	Front high-speed peck drilling cycle
G84	Tapping cycle
G85	Boring Cycle Face
G87	Drilling Cycle Side
G87.5	Side high-speed peck drilling cycle
G87.6	Side high-speed peck drilling cycle
G88	Tapping Cycle Side
G89	Bore In, Dwell, Bore Out Canned Cycle
G96	Turns on constant surface speed
G97	Cancels constant surface speed
G107	(G107) Cylindrical interpolation
G112	Polar coordinate interpolation mode
G113	Polar coordinate interpolation cancel mode
G400	Automatic tool offset compensation
G490	Automatic milling spindle orientation
M-Codes	Description
M0	Programmed stop
M1	Optional stop
M2	End of program
M3	Spindle CW
M4	Spindle CCW
M5	Spindle Stop

M-Codes	Description
M6	ATC Tool Change command
M8	Coolant On
M9	Coolant Off
M13	Spindle ON clockwise/Coolant ON
M14	Spindle ON counterclockwise/Coolant ON
M30	End of program and reset
M68	Left chuck clamp
M69	Left chuck unclamp
M98	Subprogram call
M99	Subprogram end
M168	Right chuck clamp
M169	Right chuck unclamp
M203	Mill tool spindle forward
M204	Mill tool spindle reverse
M205	Mill tool spindle stop
M463	Left spindle forward & coolant on
M464	Left spindle reverse & coolant on
M465	Left spindle stop & coolant off

5.10.6. Fidia

5.10.6.1. Fidia Milling

List of G and M-codes for Fidia Milling as of CIMCO Edit 2026.01.09

G-Codes	Description
G0	Positioning (rapid traverse)
G1	Linear interpolation (cutting feed)
G2	Circular interpolation CW or helical interpolation CW
G3	Circular interpolation CW or helical interpolation CCW
G4	Dwell
G6	Parabolic interpolation
G17	XY Plane Selection
G18	XZ Plane Selection
G19	YZ Plane Selection
G20	Cancel program rotation
G21	Program rotation
G22	Circular interpolation CW or helical interpolation CW
G23	Circular interpolation CW or helical interpolation CCW
G40	Tool radius/tool nose radius compensation : cancel, 3-dimensional cutter compensation : cancel

G-Codes	Description
G41	Tool radius/tool nose radius compensation : left, 3-dimensional cutter compensation : left
G42	Tool radius/tool nose radius compensation : right, 3-dimensional cutter compensation : right
G43	3D radius compensation (opposite direction to vector)
G44	3D radius compensation (same direction as vector)
G54	Recording of work coordinate system origin
G55	Activate work coordinate system
G70	Input in inch
G71	Input in mm
G80	Canned cycle cancel, Electronic gear box : synchronization cancellation
G82	Fixed drilling cycle
G83	Fixed deep drilling cycle
G84	Fixed tapping cycle
G85	Fixed boring cycle
G86	Fixed boring cycle (variable diameter)
G87	Axis selection for fixed cycles
G90	Absolute programming
G91	Incremental programming
G92	Activating inverse RTCP
G93	Deactivating inverse RTCP
G182	Fixed drilling cycle
G183	Fixed deep drilling cycle
G184	Fixed tapping cycle
G185	Fixed boring cycle
G186	Fixed boring cycle (variable diameter)
M-Codes	Description
M0	Programmed stop
M1	Optional stop
M2	End of program
M3	Spindle CW
M4	Spindle CCW
M5	Spindle Stop
M6	Tool Change
M8	Coolant ON - Flood coolant
M9	Coolant Off
M13	Spindle ON clockwise/Coolant ON
M14	Spindle ON counterclockwise/Coolant ON
M30	End of program and reset

5.10.7. Flexium

5.10.7.1. Flexium Milling

List of G and M-codes for Flexium Milling as of CIMCO Edit 2026.01.09

G-Codes	Description
G0	Positioning (rapid traverse)
G1	Linear interpolation (cutting feed)
G2	Circular interpolation CW or helical interpolation CW
G3	Circular interpolation CW or helical interpolation CCW
G4	Dwell
G5	Programming a movement on the inclined axis
G10	Interruptible block
G16	Definition of the tool axis orientation with addresses P, Q, R
G17	XY Plane Selection
G18	XZ Plane Selection
G19	YZ Plane Selection
G20	Programming in polar coordinates (X, Z, C)
G21	Programming in cartesian coordinates (X, Y, Z)
G22	Programming in cylindrical coordinates (X, Y, Z)
G23	Circular interpolation defined by three points
G29	Tridimensional tool correction with 3 or 5 axes
G40	Tool radius/tool nose radius compensation : cancel, 3-dimensional cutter compensation : cancel
G41	Tool radius/tool nose radius compensation : left, 3-dimensional cutter compensation : left
G42	Tool radius/tool nose radius compensation : right, 3-dimensional cutter compensation : right
G43	Tridimensional tool correction with cylindrical tool
G53	Machine coordinate system setting
G54	Workpiece coordinate system #1
G55	Workpiece coordinate system #2
G56	Workpiece coordinate system #3
G57	Workpiece coordinate system #4
G58	Workpiece coordinate system #5
G59	Program origin offset
G70	Input in inch
G71	Input in mm
G77	Unconditional branch to a subroutine or sequence of blocks with return
G79	Conditional or unconditional jump to a sequence without return
G80	Canned cycle cancel, Electronic gear box : synchronization cancellation
G81	Drilling Cycle, Spot Drilling
G82	Drilling Cycle, Counter Boring Cycle

G-Codes	Description
G83	Peck Drilling Cycle
G84	Tapping cycle
G85	Boring cycle 1
G86	Boring cycle 2
G87	Boring cycle 2
G88	Boring cycle 3
G89	Boring cycle 4
G90	Absolute programming
G91	Incremental programming
G92	Work Coordinate Systems Shift Value
G94	Feed per minute
G95	Feed per revolution
G151	Rotation around Tool Center Point

M-Codes	Description
M0	Programmed stop
M1	Optional stop
M2	End of program
M3	Spindle CW
M4	Spindle CCW
M5	Spindle Stop
M6	Tool Change
M8	Coolant 1 on
M9	Coolant Off
M30	End of program and reset

5.10.8. Haas

5.10.8.1. Haas NGC Turning

List of G and M-codes for Haas NGC Turning as of CIMCO Edit 2026.01.09

G-Codes	Description
G0	Rapid Motion Positioning
G1	Linear Interpolation Motion
G2	Circular Interpolation Motion CW
G3	Circular Interpolation Motion CCW
G4	Dwell
G17	XY Plane Selection
G18	XZ Plane Selection
G19	YZ Plane Selection

G-Codes	Description
G20	Select Inches
G21	Select Metric
G28	Return To Machine Zero Point
G30	Return To Reference position
G32	Thread Cutting
G40	Tool nose compensation cancel
G41	Tool Nose Compensation (TNC) Left
G42	Tool Nose Compensation (TNC) Right
G50	Spindle Speed Maximum RPM Limit
G52	Set Local Work Coordinate System
G53	Machine coordinate system setting
G54	Select Work Coordinate System #1
G55	Select Work Coordinate System #2
G56	Select Work Coordinate System #3
G57	Select Work Coordinate System #4
G58	Select Work Coordinate System #5
G59	Select Work Coordinate System #6
G65	Subprogram call with arguments
G70	Finishing Cycle
G71	O.D./I.D. Stock Removal Cycle
G72	End Face Stock Removal Cycle
G73	Irregular Path Stock Removal
G74	End Face Grooving Cycle
G75	O.D./I.D. Grooving Cycle
G76	Threading Cycle, Multiple Pass
G80	Canned Cycle Cancel
G81	Drill Canned Cycle
G82	Spot Drill Canned Cycle
G83	Normal Peck Drilling Canned Cycle
G84	Tapping Canned Cycle
G85	Boring Canned Cycle
G86	Bore and Stop Canned Cycle
G89	Bore In, Dwell, Bore Out Canned Cycle
G90	O.D./I.D. Turning Cycle
G92	Threading Cycle
G94	End Facing Cycle
G95	Live Tooling Rigid Tap (Face)
G96	Turns on constant surface speed
G97	Cancel constant surface speed

G-Codes	Description
G98	Feed Per Minute Mode
G99	Feed Per Revolution
G107	Cylindrical interpolation
G110	Select Work Coordinate System #7
G111	Select Work Coordinate System #8
G112	XY to XC Interpolation
G113	Cancel G112
G114	Select Work Coordinate System #9
G115	Select Work Coordinate System #10
G116	Select Work Coordinate System #11
G117	Select Work Coordinate System #12
G118	Select Work Coordinate System #13
G119	Select Work Coordinate System #14
G120	Select Work Coordinate System #15
G121	Select Work Coordinate System #16
G122	Select Work Coordinate System #17
G123	Select Work Coordinate System #18
G124	Select Work Coordinate System #19
G125	Select Work Coordinate System #20
G126	Select Work Coordinate System #21
G127	Select Work Coordinate System #22
G128	Select Work Coordinate System #23
G129	Select Work Coordinate System #24
G154	Select Work Coordinates P1-P99
G184	Reverse Tapping Canned Cycle For Left Hand Threads
G186	Reverse Live Tool Rigid Tap (For Left Hand Threads)
G187	Accuracy control
G195	Forward Live Tool Radial Tapping (Diameter)
G196	Reverse Live Tool Radial Tapping (Diameter)
G241	Radial Drill Canned Cycle
G242	Radial Spot Drill Canned Cycle
G243	Radial Normal Peck Drilling Canned Cycle
G245	Radial Boring Canned Cycle
G246	Radial Bore and Stop Canned Cycle
G249	Radial Bore and Dwell Canned Cycle
M-Codes	Description
M0	Stop Program
M1	Optional Program Stop
M2	Program End

M-Codes	Description
M3	Spindle CW
M4	Spindle CCW
M5	Spindle Stop
M6	Tool change
M8	Coolant On
M9	Coolant Off
M10	Chuck clamp
M11	Chuck unclamp
M12	Auto Air Gun On
M13	Auto Air Gun Off
M19	Orient Spindle
M23	Chamfer Out of Thread On
M24	Chamfer Out of Thread Off
M30	Program End and Reset
M59	Set Output Relay
M69	Clear Output Relay
M88	High Pressure Coolant On
M89	High Pressure Coolant Off
M96	Jump If No Input
M97	Local Subprogram Call
M98	Subprogram Call
M99	Subprogram Return / Jump / Loop
M109	Interactive User Input
M110	Secondary Spindle Chuck Clamp (Optional)
M111	Secondary Spindle Chuck Unclamp (Optional)
M133	Live Tool Fwd (Optional)
M134	Live Tool Rev (Optional)
M135	Live Tool Stop (Optional)
M154	C-Axis Engage (Optional)
M155	C-Axis Disengage (Optional)

5.10.8.2. Haas NGC Milling

List of G and M-codes for Haas NGC Milling as of CIMCO Edit 2026.01.09

G-Codes	Description
G0	Rapid Motion Positioning
G1	Linear Interpolation Motion
G2	Circular Interpolation Motion CW
G3	Circular Interpolation Motion CCW
G4	Dwell

G-Codes	Description
G10	Set Offsets
G12	Circular Pocket Milling CW
G13	Circular Pocket Milling CCW
G17	XY Plane Selection
G18	XZ Plane Selection
G19	YZ Plane Selection
G20	Select Inches
G21	Select Metric
G28	Return To Machine Zero Point
G40	Cutter Compensation Cancel
G41	2D Cutter Compensation Left
G42	2D Cutter Compensation Right
G43	Tool Length Compensation + (Add)
G44	Tool Length Compensation - (Subtract)
G47	Text Engraving
G49	G43/G44/G143 Cancel
G50	Cancel Scaling
G51	Scaling
G52	Set Work Coordinate System
G53	Machine coordinate system setting
G54	Select Work Coordinate System #1
G55	Select Work Coordinate System #2
G56	Select Work Coordinate System #3
G57	Select Work Coordinate System #4
G58	Select Work Coordinate System #5
G59	Select Work Coordinate System #6
G65	Subprogram call with arguments
G68	Rotation
G69	Cancel G68 Rotation
G70	Bolt Hole Circle
G71	Bolt Hole Arc
G72	Bolt Holes Along an Angle
G73	High-Speed Peck Drilling Canned Cycle
G74	Reverse Tap Canned Cycle
G76	Fine Boring Canned Cycle
G77	Back Bore Canned Cycle
G80	Canned Cycle Cancel
G81	Drill Canned Cycle
G82	Spot Drill Canned Cycle

G-Codes	Description
G83	Normal Peck Drilling Canned Cycle
G84	Tapping Canned Cycle
G85	Boring Canned Cycle
G86	Bore and Stop Canned Cycle
G87	Bore and Stop Canned Cycle
G89	Bore In, Dwell, Bore Out Canned Cycle
G90	Absolute programming
G91	Incremental programming
G92	Work Coordinate Systems Shift Value
G94	Feed Per Minute Mode
G95	Feed Per Revolution
G98	Canned Cycle Initial Point Return
G99	Canned Cycle R Plane Return
G100	Cancel Mirror Image
G101	Enable Mirror Image
G110	Select Work Coordinate System #7
G111	Select Work Coordinate System #8
G112	Select Work Coordinate System #9
G113	Select Work Coordinate System #10
G114	Select Work Coordinate System #11
G115	Select Work Coordinate System #12
G116	Select Work Coordinate System #13
G117	Select Work Coordinate System #14
G118	Select Work Coordinate System #15
G119	Select Work Coordinate System #16
G120	Select Work Coordinate System #17
G121	Select Work Coordinate System #18
G122	Select Work Coordinate System #19
G123	Select Work Coordinate System #20
G124	Select Work Coordinate System #21
G125	Select Work Coordinate System #22
G126	Select Work Coordinate System #23
G127	Select Work Coordinate System #24
G128	Select Work Coordinate System #25
G129	Select Work Coordinate System #26
G150	General Purpose Pocket Milling
G154	Select Work Coordinates P1-P99
G187	Setting the Smoothness Level
G234	Tool Center Point Control (TCPC)

G-Codes	Description
G253	Orient Spindle Normal To Feature Coordinate System
G254	Dynamic Work Offset (DWO)
G255	Cancel Dynamic Work Offset (DWO)
G268	Feature Coordinate System command
G269	Cancel tilted plane
M-Codes	Description
M0	Stop Program
M1	Optional Program Stop
M2	Program End
M3	Spindle CW
M4	Spindle CCW
M5	Spindle Stop
M6	Tool Change
M7	Shower Coolant On
M8	Coolant On
M9	Coolant Off
M10	Engage 4th Axis Brake
M11	Release 4th Axis Brak
M12	Engage 5th Axis Brake
M13	Release 5th Axis Brake
M16	Tool Change
M19	Orient Spindle
M30	Program End and Reset
M56	Set Output Relay
M69	Clear Output Relay
M73	Tool Air Blast On
M74	Tool Air Blast Off
M83	Auto Air Gun On
M84	Auto Air Gun Off
M88	Through-Spindle Coolant On
M89	Through-Spindle Coolant Off
M96	Jump If No Input
M97	Local Subprogram Call
M98	Subprogram Call
M99	Subprogram Return / Jump / Loop
M109	Interactive User Input

5.10.8.3. Haas VR Milling

List of G and M-codes for Haas VR Milling as of CIMCO Edit 2026.01.09

G-Codes	Description
G0	Rapid Motion Positioning
G1	Linear Interpolation Motion
G2	Circular Interpolation Motion CW
G3	Circular Interpolation Motion CCW
G4	Dwell
G10	Set Offsets
G12	Circular Pocket Milling CW
G13	Circular Pocket Milling CCW
G17	XY Plane Selection
G18	XZ Plane Selection
G19	YZ Plane Selection
G20	Select Inches
G21	Select Metric
G28	Return To Machine Zero Point
G40	Cutter Compensation Cancel
G41	2D Cutter Compensation Left
G42	2D Cutter Compensation Right
G43	Tool Length Compensation + (Add)
G44	Tool Length Compensation - (Subtract)
G47	Text Engraving
G49	G43/G44/G143 Cancel
G50	Cancel Scaling
G51	Scaling
G52	Set Work Coordinate System
G53	Machine coordinate system setting
G54	Select Work Coordinate System #1
G55	Select Work Coordinate System #2
G56	Select Work Coordinate System #3
G57	Select Work Coordinate System #4
G58	Select Work Coordinate System #5
G59	Select Work Coordinate System #6
G65	Subprogram call with arguments
G68	Rotation
G69	Cancel G68 Rotation
G70	Bolt Hole Circle
G71	Bolt Hole Arc
G72	Bolt Holes Along an Angle
G73	High-Speed Peck Drilling Canned Cycle
G74	Reverse Tap Canned Cycle

G-Codes	Description
G76	Fine Boring Canned Cycle
G77	Back Bore Canned Cycle
G80	Canned Cycle Cancel
G81	Drill Canned Cycle
G82	Spot Drill Canned Cycle
G83	Normal Peck Drilling Canned Cycle
G84	Tapping Canned Cycle
G85	Boring Canned Cycle
G86	Bore and Stop Canned Cycle
G87	Bore and Stop Canned Cycle
G89	Bore In, Dwell, Bore Out Canned Cycle
G90	Absolute programming
G91	Incremental programming
G92	Work Coordinate Systems Shift Value
G94	Feed Per Minute Mode
G95	Feed Per Revolution
G98	Canned Cycle Initial Point Return
G99	Canned Cycle R Plane Return
G100	Cancel Mirror Image
G101	Enable Mirror Image
G110	Select Work Coordinate System #7
G111	Select Work Coordinate System #8
G112	Select Work Coordinate System #9
G113	Select Work Coordinate System #10
G114	Select Work Coordinate System #11
G115	Select Work Coordinate System #12
G116	Select Work Coordinate System #13
G117	Select Work Coordinate System #14
G118	Select Work Coordinate System #15
G119	Select Work Coordinate System #16
G120	Select Work Coordinate System #17
G121	Select Work Coordinate System #18
G122	Select Work Coordinate System #19
G123	Select Work Coordinate System #20
G124	Select Work Coordinate System #21
G125	Select Work Coordinate System #22
G126	Select Work Coordinate System #23
G127	Select Work Coordinate System #24
G128	Select Work Coordinate System #25

G-Codes	Description
G129	Select Work Coordinate System #26
G141	3D+ Cutter Compensation
G143	5-Axis Tool Length Compensation +
G150	General Purpose Pocket Milling
G153	5-Axis High Speed Peck Drilling Canned Cycle
G154	Select Work Coordinates P1-P99
G155	5-Axis Reverse Tap Canned Cycle
G161	5-Axis Drill Canned Cycle
G162	5-Axis Spot Drill Canned Cycle
G163	5-Axis Normal Peck Drilling Canned Cycle
G164	5-Axis Tapping Canned Cycle
G165	5-Axis Boring Canned Cycle
G166	5-Axis Bore and Stop Canned Cycle
G169	5-Axis Bore and Dwell Canned Cycle
G174	CCW Non-Vertical Rigid Tap
G184	CW Non-Vertical Rigid Tap
G187	Accuracy Control
G234	Tool Center Point Control (TCPC)
G253	Orient Spindle Normal To Feature Coordinate System
G254	Dynamic Work Offset (DWO)
G255	Cancel Dynamic Work Offset (DWO)
G268	Feature Coordinate System command
G269	Cancel tilted plane
M-Codes	Description
M0	Stop Program
M1	Optional Program Stop
M2	Program End
M3	Spindle CW
M4	Spindle CCW
M5	Spindle Stop
M6	Tool Change
M7	Shower Coolant On
M8	Coolant On
M9	Coolant Off
M10	Engage 4th Axis Brake
M11	Release 4th Axis Brak
M12	Engage 5th Axis Brake
M13	Release 5th Axis Brake
M16	Tool Change

M-Codes	Description
M19	Orient Spindle
M30	Program End and Reset
M56	Set Output Relay
M69	Clear Output Relay
M73	Tool Air Blast On
M74	Tool Air Blast Off
M83	Auto Air Gun On
M84	Auto Air Gun Off
M88	Through-Spindle Coolant On
M89	Through-Spindle Coolant Off
M96	Jump If No Input
M97	Local Subprogram Call
M98	Subprogram Call
M99	Subprogram Return / Jump / Loop
M109	Interactive User Input

5.10.8.4. Haas UMC Milling

List of G and M-codes for Haas UMC Milling as of CIMCO Edit 2026.01.09

G-Codes	Description
G0	Rapid Motion Positioning
G1	Linear Interpolation Motion
G2	Circular Interpolation Motion CW
G3	Circular Interpolation Motion CCW
G4	Dwell
G10	Set Offsets
G12	Circular Pocket Milling CW
G13	Circular Pocket Milling CCW
G17	XY Plane Selection
G18	XZ Plane Selection
G19	YZ Plane Selection
G20	Select Inches
G21	Select Metric
G28	Return To Machine Zero Point
G40	Cutter Compensation Cancel
G41	2D Cutter Compensation Left
G42	2D Cutter Compensation Right
G43	Tool Length Compensation + (Add)
G44	Tool Length Compensation - (Subtract)
G47	Text Engraving

G-Codes	Description
G49	G43/G44/G143 Cancel
G50	Cancel Scaling
G51	Scaling
G52	Set Work Coordinate System
G53	Machine coordinate system setting
G54	Select Work Coordinate System #1
G55	Select Work Coordinate System #2
G56	Select Work Coordinate System #3
G57	Select Work Coordinate System #4
G58	Select Work Coordinate System #5
G59	Select Work Coordinate System #6
G65	Subprogram call with arguments
G68	Rotation
G69	Cancel G68 Rotation
G70	Bolt Hole Circle
G71	Bolt Hole Arc
G72	Bolt Holes Along an Angle
G73	High-Speed Peck Drilling Canned Cycle
G74	Reverse Tap Canned Cycle
G76	Fine Boring Canned Cycle
G77	Back Bore Canned Cycle
G80	Canned Cycle Cancel
G81	Drill Canned Cycle
G82	Spot Drill Canned Cycle
G83	Normal Peck Drilling Canned Cycle
G84	Tapping Canned Cycle
G85	Boring Canned Cycle
G86	Bore and Stop Canned Cycle
G87	Bore and Stop Canned Cycle
G89	Bore In, Dwell, Bore Out Canned Cycle
G90	Absolute programming
G91	Incremental programming
G92	Work Coordinate Systems Shift Value
G94	Feed Per Minute Mode
G95	Feed Per Revolution
G98	Canned Cycle Initial Point Return
G99	Canned Cycle R Plane Return
G100	Cancel Mirror Image
G101	Enable Mirror Image

G-Codes	Description
G103	Limit Block Buffering
G110	Select Work Coordinate System #7
G111	Select Work Coordinate System #8
G112	Select Work Coordinate System #9
G113	Select Work Coordinate System #10
G114	Select Work Coordinate System #11
G115	Select Work Coordinate System #12
G116	Select Work Coordinate System #13
G117	Select Work Coordinate System #14
G118	Select Work Coordinate System #15
G119	Select Work Coordinate System #16
G120	Select Work Coordinate System #17
G121	Select Work Coordinate System #18
G122	Select Work Coordinate System #19
G123	Select Work Coordinate System #20
G124	Select Work Coordinate System #21
G125	Select Work Coordinate System #22
G126	Select Work Coordinate System #23
G127	Select Work Coordinate System #24
G128	Select Work Coordinate System #25
G129	Select Work Coordinate System #26
G150	General Purpose Pocket Milling
G154	Select Work Coordinates P1-P99
G187	Setting the Smoothness Level
G234	Tool Center Point Control (TCPC)
G254	Dynamic Work Offset (DWO)
G255	Cancel Dynamic Work Offset (DWO)
G268	Feature Coordinate System command
G269	Cancel tilted plane
M-Codes	Description
M0	Stop Program
M1	Optional Program Stop
M2	Program End
M3	Spindle CW
M4	Spindle CCW
M5	Spindle Stop
M6	Tool Change
M7	Shower Coolant On
M8	Coolant On

M-Codes	Description
M9	Coolant Off
M10	Engage 4th Axis Brake
M11	Release 4th Axis Brak
M12	Engage 5th Axis Brake
M13	Release 5th Axis Brake
M16	Tool Change
M19	Orient Spindle
M30	Program End and Reset
M56	Set Output Relay
M69	Clear Output Relay
M73	Tool Air Blast On
M74	Tool Air Blast Off
M83	Auto Air Gun On
M84	Auto Air Gun Off
M88	Through-Spindle Coolant On
M89	Through-Spindle Coolant Off
M96	Jump If No Input
M97	Local Subprogram Call
M98	Subprogram Call
M99	Subprogram Return / Jump / Loop
M109	Interactive User Input

5.10.9. Heidenhain

5.10.9.1. Heidenhain ISO Milling

List of G and M-codes for Heidenhain ISO Milling as of CIMCO Edit 2026.01.09

G-Codes	Description
G0	Rapid positioning
G1	Linear cutting positioning
G2	Circular interpolation clockwise
G3	Circular interpolation clockwise
G4	Dwell time
G5	Circular interpolation, Cartesian coordinates, without indication of direction
G6	Circular arc with tangential connection to the preceding contour element
G7	Paraxial positioning block
G10	Straight-line interpolation, polar coordinates, rapid traverse
G11	Straight-line interpolation, polar coordinates, with feedrate
G12	Circular interpolation, polar coordinates, CW

G-Codes	Description
G13	Circular interpolation, polar coordinates, CCW
G15	Circular interpolation, polar coordinates, without programmed direction
G16	Circular path with tangential connection
G17	XY Plane Selection
G18	XZ Plane Selection
G19	YZ Plane Selection
G24	Chamfer between line segments
G25	Rounding between line segments
G26	Approaching on a straight line with tangential connection
G27	Departing on a straight line with tangential connection
G28	Mirror image
G29	Transfer the last nominal position value as a pole (circle center)
G30	Minimum point of the blank
G31	Maximum point of the blank
G36	Spindle orientation
G37	CONTOUR GEOMETRY
G38	STOP program run
G39	Subprogram call
G40	Disabled radius compensation
G41	Tool radius/tool nose radius compensation : left, 3-dimensional cutter compensation : left
G42	Tool radius/tool nose radius compensation : right, 3-dimensional cutter compensation : right
G43	Paraxial compensation for G07, lengthening
G44	Paraxial compensation for G07, shortening
G51	Next tool number (with central tool file)
G53	Datum shift in datum table
G54	Datum shift in program
G55	Measure any coordinate
G62	Tolerance deviation for fast contour milling
G70	Input in inch
G71	Input in mm
G72	Scaling factor
G73	Pattern rotation
G79	Cycle call
G80	Tilting the working plane
G90	Absolute programming
G91	Incremental programming
G98	Subprogram label definition
G99	Tool definition
G120	Contour data

G-Codes	Description
G121	PILOT DRILLING
G122	ROUGH-OUT
G123	FLOOR FINISHING
G124	SIDE FINISHING
G200	Drilling
G201	Reaming
G202	Boring
G203	Universal drilling
G204	Back boring
G205	Universal pecking
G206	Tapping New with a floating tap holder
G207	Rigid Tapping without a floating tap holder New
G208	Bore milling
G209	Tapping with chip breaking
G220	Polar pattern
G221	Cartesian pattern
G230	Multipass milling
G231	Ruled surface
G232	Face milling
G233	Face milling
G240	Single-lip deep hole drilling
G241	Single-lip deep hole drilling
G247	Datum setting
G251	Rectangular pocket
G252	Circular pocket
G253	Slot milling
G254	Slot milling
G256	Rectangular stud finishing
G257	Circular pocket finishing
G262	Thread milling
G263	THREAD MILLING/COUNTERSINKING
G264	Thread milling
G265	Thread milling
G267	Thread milling
G302	Head orientation
G309	Tolerance
G326	Tolerance
G327	???
G330	???

G-Codes	Description
G332	Tuning
G400	Basic rotation
G401	Basic rotation from 2 holes
G402	Basic rotation over 2 studs
G403	Basic rotation compensation via rotary axis
G404	SET BASIC ROTATION
G405	Compensating workpiece misalignment by rotating the C-axis
G408	SLOT CENTER REF PT
G409	RIDGE CENTER REF PT
G410	DATUM FROM INSIDE OF RECTANGLE
G411	DATUM FROM OUTSIDE OF RECTANGLE
G412	DATUM FROM INSIDE OF CIRCLE
G413	DATUM FROM OUTSIDE OF CIRCLE
G414	DATUM FROM OUTSIDE OF CORNER
G415	DATUM FROM INSIDE OF CORNER
G416	DATUM CIRCLE CENTER
G417	DATUM IN TOUCH PROBE AXIS
G418	DATUM AT CENTER OF 4 HOLES
G419	DATUM IN ONE AXIS
G420	MEASURE ANGLE
G421	MEASURE HOLE
G422	MEAS. CIRCLE OUTSIDE
G423	MEAS. RECTAN. INSIDE
G424	MEASURE RECTANGLE OUTSIDE
G425	MEASURE INSIDE WIDTH
G426	MEASURE RIDGE WIDTH
G427	MEASURE COORDINATE
G430	MEASURE BOLT HOLE CIRCLE
G431	MEASURE PLANE
G441	Fast probing
G480	Calibrate the TT
G481	Measure the tool length
G482	Measure the tool radius
G483	Measure the tool length and radius
M-Codes	Description
M0	Program STOP, Spindle STOP
M1	Optional program STOP
M2	Program end
M3	Spindle ON clockwise

M-Codes	Description
M4	Spindle ON counterclockwise
M5	Spindle STOP
M8	Coolant On
M9	Coolant Off
M13	Spindle ON clockwise/Coolant ON
M14	Spindle ON counterclockwise/Coolant ON
M30	End of program and reset
M89	Cycle call in every block until M99 or new cycle def is called
M91	Machine datum coordinates
M92	Additional machine datum coordinates
M94	Reduce display value of rotary axes
M99	Blockwise cycle call
M126	Shortest-path traverse of rotary axes
M127	Reset M126
M128	Tool center point management
M129	Reset M128
M130	Moving to positions in a non-tilted coordinate system with a tilted working plane
M140	Retraction from the contour in the tool-axis direction

5.10.9.2. Heidenhain Milling with Turning

List of M-codes for Heidenhain Milling with Turning as of CIMCO Edit 2026.01.09

M-Codes	Description
M0	Program STOP, Spindle STOP
M1	Optional program STOP
M2	Program end
M3	Spindle ON clockwise
M4	Spindle ON counterclockwise
M5	Spindle STOP
M8	Coolant On
M9	Coolant Off
M13	Spindle ON clockwise/Coolant ON
M14	Spindle ON counterclockwise/Coolant ON
M30	End of program and reset
M89	Cycle call in every block until M99 or new cycle def is called
M91	Machine datum coordinates
M92	Additional machine datum coordinates
M94	Reduce display value of rotary axes
M99	Blockwise cycle call
M126	Shortest-path traverse of rotary axes
M127	Reset M126
M128	Tool center point management
M129	Reset M128
M130	Moving to positions in a non-tilted coordinate system with a tilted working plane
M136	Feed in mm/rev
M137	Feed in mm/min
M138	Axes the TNC has available to calculate the result of a rotation
M140	Retraction from the contour in the tool-axis direction
M303	Workpiece spindle clockwise rotation
M304	Workpiece spindle counter-clockwise rotation
M305	Spindle Stop
M319	Workpiece spindle orientation

5.10.9.3. Heidenhain Milling

List of M-codes for Heidenhain Milling as of CIMCO Edit 2026.01.09

M-Codes	Description
M0	Program STOP, Spindle STOP
M1	Optional program STOP
M2	Program end
M3	Spindle ON clockwise
M4	Spindle ON counterclockwise
M5	Spindle STOP
M8	Coolant On
M9	Coolant Off
M13	Spindle ON clockwise/Coolant ON
M14	Spindle ON counterclockwise/Coolant ON
M30	End of program and reset
M89	Cycle call in every block until M99 or new cycle def is called
M91	Machine datum coordinates
M92	Additional machine datum coordinates
M94	Reduce display value of rotary axes
M99	Blockwise cycle call
M126	Shortest-path traverse of rotary axes
M127	Reset M126
M128	Tool center point management
M129	Reset M128
M130	Moving to positions in a non-tilted coordinate system with a tilted working plane
M138	Axes the TNC has available to calculate the result of a rotation
M140	Retraction from the contour in the tool-axis direction

5.10.10. Hurco

5.10.10.1. Hurco Milling

List of G and M-codes for Hurco Milling as of CIMCO Edit 2026.01.09

G-Codes	Description
G0	Positioning (rapid traverse)
G1	Linear interpolation (cutting feed)
G2	Circular interpolation CW or helical interpolation CW
G2_4	Circular interpolation CW or helical interpolation CW
G3	Circular interpolation CW or helical interpolation CCW
G3_4	Circular interpolation CW or helical interpolation CCW

G-Codes	Description
G4	Dwell
G5_1	Surface Finish
G5_2	Data smoothing
G5_3	Surface finish quality
G8_1	ASR Command Buffer On
G8_2	ASR Command Buffer Off
G10	Programmable data input
G17	XY Plane Selection
G18	XZ Plane Selection
G19	YZ Plane Selection
G20	Input in inch
G21	Input in mm
G28	Automatic return to reference position
G30	2nd, 3rd and 4th reference position return
G40	Tool radius/tool nose radius compensation : cancel, 3-dimensional cutter compensation : cancel
G41	Tool radius/tool nose radius compensation : left, 3-dimensional cutter compensation : left
G42	Tool radius/tool nose radius compensation : right, 3-dimensional cutter compensation : right
G43	Tool length compensation +
G43_4	5-Axis Linear Interpolation
G44	Tool length compensation -
G49	Tool length compensation cancel
G52	Local coordinate system setting
G53	Machine coordinate system setting
G54	Workpiece coordinate system #1
G54_1	Additional workpiece coordinate systems
G54_2	Additional workpiece coordinate systems
G55	Workpiece coordinate system #2
G56	Workpiece coordinate system #3
G57	Workpiece coordinate system #4
G58	Workpiece coordinate system #5
G59	Workpiece coordinate system #6
G65	Subprogram call with arguments
G68	3-dimensional coordinate system conversion
G68_2	Tilted working plane command
G68_3	Local Rotation NC Transform Plane
G69	3-D coordinate conversion OFF
G69_1	Cancel All Active Transform Planes
G73	High-Speed Peck Drilling Cycle
G74	Left-Handed Tapping Cycle

G-Codes	Description
G76	Fine Boring Cycle
G80	Canned cycle cancel, Electronic gear box : synchronization cancellation
G81	Drilling Cycle, Spot Drilling
G82	Drilling Cycle, Counter Boring Cycle
G83	Peck Drilling Cycle
G84	Tapping cycle
G84_2	Rigid Tapping Cycle
G84_3	Rigid Tapping Cycle
G85	Boring cycle 1
G86	Boring cycle 2
G87	Boring cycle 2
G88	Boring cycle 3
G89	Boring cycle 4
G90	Absolute programming
G91	Incremental programming
G92	Work Coordinate Systems Shift Value
G92_1	Workpiece Coordinate System Preset
G94	Feed per minute
G95	Feed per revolution
G98	Canned cycle : return to initial level
G99	Canned cycle : return to R point level
M-Codes	Description
M0	Programmed stop
M1	Optional stop
M2	End of program
M3	Spindle CW
M4	Spindle CCW
M5	Spindle Stop
M6	Tool Change
M7	Switches on secondary coolant systems
M8	Switches on primary coolant system
M9	Switches off both the primary and secondary coolant
M30	End of program and reset
M31	??
M98	Subprogram call
M99	Subprogram end
M126	Shortest Rotary Angle Path Traverse
M127	Cancel Shortest Rotary Angle Path Traverse (M126)
M128	Tool Center Point Management

M-Codes	Description
M129	Cancels Tool Center Point Management (M128)
M140	Retraction from the contour in the tool-axis direction

5.10.11. Mazak

5.10.11.1. Mazak Turning

List of G and M-codes for Mazak Turning as of CIMCO Edit 2026.01.09

G-Codes	Description
G0	Rapid Motion Positioning
G1	Linear Interpolation Motion
G2	Circular Interpolation Motion CW
G3	Circular Interpolation Motion CCW
G4	Dwell
G7.1	(G107) Cylindrical interpolation
G10	Programmable data input
G17	XY Plane Selection
G18	XZ Plane Selection
G19	YZ Plane Selection
G28	Return To Machine Zero Point
G30	2nd, 3rd and 4th reference position return
G30.1	Return to floating reference point
G40	Tool nose compensation cancel
G41	Tool Nose Compensation (TNC) Left
G42	Tool Nose Compensation (TNC) Right
G46	Tool nose radius compensation (automatic direction selection) ON
G54	Select Work Coordinate System #1
G55	Select Work Coordinate System #2
G56	Select Work Coordinate System #3
G57	Select Work Coordinate System #4
G58	Select Work Coordinate System #5
G59	Select Work Coordinate System #6
G65	Subprogram call with arguments
G66	Modal Subprogram set with arguments
G66_1	Modal Subprogram set with arguments
G67	Cancel modal subprogram call
G80	Canned Cycle Cancel
G83	Front drill cycle
G84	Front tap cycle

G-Codes	Description
G84.2	Front synchronous tap cycle
G85	Front boring cycle
G87	Side drill cycle
G88	Side tap cycle
G88.2	Side synchronous tap cycle
G89	Side boring cycle
G96	Turns on constant surface speed
G97	Cancel constant surface speed
G107	(G107) Cylindrical interpolation
M-Codes	Description
M0	Programmed stop
M1	Optional stop
M2	End of program
M3	Spindle CW
M4	Spindle CCW
M5	Spindle Stop
M8	Coolant On
M9	Coolant Off
M30	End of program and reset
M98	Subprogram call
M99	Subprogram end
M198	External subprogram call
M199	External subprogram call
M203	Milling tool normal rotation
M204	Milling tool reverse rotation
M205	Milling tool stop

5.10.11.2. Mazak Integrex

List of G and M-codes for Mazak Integrex as of CIMCO Edit 2026.01.09

G-Codes	Description
G0	Rapid Motion Positioning
G1	Linear Interpolation Motion
G2	Circular Interpolation Motion CW
G3	Circular Interpolation Motion CCW
G4	Dwell
G5	High-speed machining mode
G7.1	Cylindrical interpolation
G10.9	Selection between diameter and radius data input
G12.1	Milling interpolation ON

G-Codes	Description
G13.1	Milling interpolation OFF
G15	Polar coordinate interpolation OFF
G16	Polar coordinate interpolation ON
G17	XY Plane Selection
G18	XZ Plane Selection
G19	YZ Plane Selection
G20	Select Inches
G21	Select Metric
G28	Return To Machine Zero Point
G30	2nd, 3rd and 4th reference position return
G32	Thread Cutting
G33	Thread Cutting
G40	Tool nose compensation cancel
G41	Tool Nose Compensation (TNC) Left
G41.2	Tool radius compensation for five-axis machining (left)
G42	Tool Nose Compensation (TNC) Right
G42.2	Tool radius compensation for five-axis machining (right)
G43	Tool length compensation +
G43.1	Tool length offset in tool-axis direction
G43.4	Tool center point control (type 1)
G43.5	Tool center point control (type 2)
G49	Tool length compensation cancel
G53	Machine coordinate system setting
G53.1	Tool-axis direction control
G54	Select Work Coordinate System #1
G54.1	Selection of additional workpiece coordinate systems
G54.2	Dynamic offsetting II
G54.4	Workpiece setup error correction
G55	Select Work Coordinate System #2
G56	Select Work Coordinate System #3
G57	Select Work Coordinate System #4
G58	Select Work Coordinate System #5
G59	Select Work Coordinate System #6
G65	Subprogram call with arguments
G68	3-D coordinate conversion ON
G68.2	Inclined-plane machining ON
G68.3	Inclined-plane machining (by specifying tool-axis direction) ON
G69	3-D coordinate conversion OFF
G73	Fixed cycle (High-speed deep-hole drilling)

G-Codes	Description
G74	Fixed cycle (Reverse tapping)
G75	Fixed cycle (Boring 1)
G77	Fixed cycle (Back spot facing)
G80	Fixed cycle OFF
G81	Drilling Cycle, Spot Drilling
G82	Drilling Cycle, Counter Boring Cycle
G82.2	Drilling Cycle, Counter Boring Cycle
G83	Front drill cycle
G84	Front tap cycle
G84.2	Front synchronous tap cycle
G84.3	Synchronous reverse tapping
G85	Front boring cycle
G87	Side drill cycle
G88	Side tap cycle
G89	Side boring cycle
G90	Absolute programming
G91	Incremental programming
G92	Spindle Speed Maximum RPM Limit
G94	Feed Per Minute Mode
G95	Feed Per Revolution
G96	Turns on constant surface speed
G97	Cancels constant surface speed
G98	Initial point level return
G99	R-point level return
G270	Finishing Cycle
G271	Longitudinal rough cutting cycle
G272	Transverse roughing cycle (leaving finishing allowance)
G273	Formed material rough cutting cycle
G274	Longitudinal cut-off cycle
G275	Transverse cut-off cycle
G276	Compound thread cutting cycle
G283	Front drill cycle
G284	Front tap cycle
G285	Front boring cycle
G290	Longitudinal turning cycle
G292	Thread Cutting
G294	End Facing Cycle
M-Codes	Description
M0	Programmed stop

M-Codes	Description
M1	Optional stop
M2	End of program
M3	Spindle CW
M4	Spindle CCW
M5	Spindle Stop
M6	Tool Change
M8	Coolant On
M9	Coolant Off
M30	End of program and reset
M98	Subprogram call
M99	Subprogram end
M198	External subprogram call
M199	External subprogram call
M203	Milling tool normal rotation
M204	Milling tool reverse rotation
M205	Milling tool stop

5.10.11.3. Mazak Milling

List of G and M-codes for Mazak Milling as of CIMCO Edit 2026.01.09

G-Codes	Description
G0	Positioning (rapid traverse)
G1	Linear interpolation (cutting feed)
G2	Circular interpolation CW or helical interpolation CW
G3	Circular interpolation CW or helical interpolation CCW
G4	Dwell
G10	Data setting mode ON
G12_1	Polar Coordinate Interpolation ON
G13_1	Polar Coordinate Interpolation OFF
G17	XY Plane Selection
G18	XZ Plane Selection
G19	YZ Plane Selection
G20	Inch command
G21	Metric command
G28	Reference point return
G30	Return to 2nd, 3rd and 4th reference points
G34_1	Hole machining pattern cycle (on a circle)
G35	Hole machining pattern cycle (on a line)
G36	Hole machining pattern cycle (on an arc)
G37_1	Hole machining pattern cycle (on a grid)

G-Codes	Description
G40	Tool radius compensation OFF
G41	Tool radius compensation (left)
G42	Tool radius compensation (right)
G43	Tool length offset (+)
G43_4	Tool center point control (type 1)
G43_5	Tool center point control (type 2)
G44	Tool length offset (-)
G49	Tool length compensation cancel
G52	Local coordinate system setting
G53	Machine coordinate system selection
G53_1	Tool-axis direction control
G54	Select Work Coordinate System #1
G54_1	Additional workpiece coordinate systems
G54_2	Selection of fixture offset
G54_4	Workpiece setup error correction
G55	Select Work Coordinate System #2
G56	Select Work Coordinate System #3
G57	Select Work Coordinate System #4
G58	Select Work Coordinate System #5
G59	Select Work Coordinate System #6
G65	Subprogram call with arguments
G66	Modal Subprogram set with arguments
G66_1	Modal Subprogram set with arguments
G67	Cancel modal subprogram call
G68	3-dimensional coordinate system conversion
G68_2	Inclined-plane machining ON
G68_3	Inclined-plane machining (by specifying tool-axis direction) ON
G68_4	Incremental coordinate system establishment for inclined-plane machining
G69	3-D coordinate conversion OFF
G73	Fixed cycle (High-speed deep-hole drilling)
G74	Fixed cycle (Reverse tapping)
G75	Fixed cycle (Boring 1)
G76	Fixed cycle (Boring 2)
G77	Fixed cycle (Back spot facing)
G78	Fixed cycle (Boring 3)
G79	Fixed cycle (Boring 4)
G80	Fixed cycle OFF
G81	Fixed cycle (Spot drilling)
G82	Fixed cycle (Drilling)

G-Codes	Description
G83	Fixed cycle (Deep-hole drilling)
G84	Fixed cycle (Tapping)
G84_2	Fixed cycle (Synchronous tapping)
G84_3	Fixed cycle (Synchronous reverse tapping)
G85	Fixed cycle (Reaming)
G86	Fixed cycle (Boring 5)
G87	Fixed cycle (Back boring)
G88	Fixed cycle (Boring 6)
G89	Fixed cycle (Boring 7)
G90	Absolute programming
G91	Incremental programming
G92	Coordinate System Setting
G94	Feed per minute (asynchronous)
G95	Feed per revolution (synchronous)
G98	Initial point level return in fixed cycles
G99	R-point level return in fixed cycles
M-Codes	Description
M0	Programmed stop
M1	Optional stop
M2	Program end
M3	Start of forward milling spindle rotation
M4	Start of backward milling spindle rotation
M5	Stop of milling spindle rotation
M6	Tool Change
M8	Coolant On
M9	Coolant Off
M30	End of program and reset
M98	Subprogram call
M99	Subprogram Return / Loop

5.10.11.4. Mazak SmoothAi Milling

List of G and M-codes for Mazak SmoothAi Milling as of CIMCO Edit 2026.01.09

G-Codes	Description
G0	Positioning (rapid traverse)
G1	Linear interpolation (cutting feed)
G2	Circular interpolation CW or helical interpolation CW
G3	Circular interpolation CW or helical interpolation CCW
G4	Dwell
G5	High-speed machining mode

G-Codes	Description
G10	Data setting mode ON
G12	Circle Cutting CW
G12_1	Polar Coordinate Interpolation ON
G13	Circle Cutting CCW
G13_1	Polar Coordinate Interpolation OFF
G17	XY Plane Selection
G18	XZ Plane Selection
G19	YZ Plane Selection
G20	Inch command
G21	Metric command
G28	Reference point return
G30	Return to 2nd, 3rd and 4th reference points
G34_1	Hole machining pattern cycle (on a circle)
G35	Hole machining pattern cycle (on a line)
G36	Hole machining pattern cycle (on an arc)
G37_1	Hole machining pattern cycle (on a grid)
G40	Tool radius compensation OFF
G41	Tool radius compensation (left)
G42	Tool radius compensation (right)
G43	Tool length offset (+)
G43_4	Tool tip point control (type 1)
G43_5	Tool tip point control (type 2)
G44	Tool length offset (-)
G49	Tool length compensation cancel
G52	Local coordinate system setting
G53	Machine coordinate system selection
G53_1	Tool-axis direction control
G54	Select Work Coordinate System #1
G54_1	Additional workpiece coordinate systems
G54_2	Selection of fixture offset
G54_4	Workpiece setup error correction
G55	Select Work Coordinate System #2
G56	Select Work Coordinate System #3
G57	Select Work Coordinate System #4
G58	Select Work Coordinate System #5
G59	Select Work Coordinate System #6
G61_1	High-accuracy mode (Geometry compensation)
G65	Subprogram call with arguments
G66	Modal Subprogram set with arguments

G-Codes	Description
G66_1	Modal Subprogram set with arguments
G67	Cancel modal subprogram call
G68	3-dimensional coordinate system conversion
G68_2	Inclined-plane machining ON
G68_3	Inclined-plane machining (by specifying tool-axis direction) ON
G68_4	Incremental coordinate system establishment for inclined-plane machining
G69	3-D coordinate conversion OFF
G73	Fixed cycle (High-speed deep-hole drilling)
G74	Fixed cycle (Reverse tapping)
G75	Fixed cycle (Boring 1)
G76	Fixed cycle (Boring 2)
G77	Fixed cycle (Back spot facing)
G78	Fixed cycle (Boring 3)
G79	Fixed cycle (Boring 4)
G80	Fixed cycle OFF
G81	Fixed cycle (Spot drilling)
G82	Fixed cycle (Drilling)
G83	Fixed cycle (Deep-hole drilling)
G84	Fixed cycle (Tapping)
G84_2	Fixed cycle (Synchronous tapping)
G84_3	Fixed cycle (Synchronous reverse tapping)
G85	Fixed cycle (Reaming)
G86	Fixed cycle (Boring 5)
G87	Fixed cycle (Back boring)
G88	Fixed cycle (Boring 6)
G89	Fixed cycle (Boring 7)
G90	Absolute programming
G91	Incremental programming
G92	Coordinate System Setting
G94	Feed per minute (asynchronous)
G95	Feed per revolution (synchronous)
G98	Initial point level return in fixed cycles
G99	R-point level return in fixed cycles
M-Codes	Description
M0	Programmed stop
M1	Optional stop
M2	Program end
M3	Start of forward milling spindle rotation
M4	Start of backward milling spindle rotation

M-Codes	Description
M5	Stop of milling spindle rotation
M6	Tool Change
M8	Coolant On
M9	Coolant Off
M30	End of program and reset
M98	Subprogram call
M99	Subprogram Return / Loop

5.10.11.5. Mazak SmoothAi Milling with Turning

List of G and M-codes for Mazak SmoothAi Milling with Turning as of CIMCO Edit 2026.01.09

G-Codes	Description
G0	Positioning (rapid traverse)
G1	Linear interpolation (cutting feed)
G2	Circular interpolation CW or helical interpolation CW
G3	Circular interpolation CW or helical interpolation CCW
G4	Dwell
G5	High-speed machining mode
G10	Data setting mode ON
G10_9	Selection between diameter and radius data input
G12	Circle Cutting CW
G12_1	Polar Coordinate Interpolation ON
G13	Circle Cutting CCW
G13_1	Polar Coordinate Interpolation OFF
G17	XY Plane Selection
G18	XZ Plane Selection
G18_1	Milling mode selection (Turning mode OFF)
G18_2	Selection of turning plane for A-axis positioning to 0 (for machining on the positive side of the Y-axis in the machine coordinate system)
G18_3	Selection of turning plane for A-axis positioning to -90
G18_4	Selection of turning plane for A-axis positioning to 0 (for machining on the negative side of the Y-axis in the machine coordinate system)
G18_9	Temporary cancellation of G18.2/G18.3/G18.4
G19	YZ Plane Selection
G20	Inch command
G21	Metric command
G28	Reference point return
G30	Return to 2nd, 3rd and 4th reference points
G34_1	Hole machining pattern cycle (on a circle)
G35	Hole machining pattern cycle (on a line)

G-Codes	Description
G36	Hole machining pattern cycle (on an arc)
G37_1	Hole machining pattern cycle (on a grid)
G40	Tool radius compensation OFF
G41	Tool radius compensation (left)
G42	Tool radius compensation (right)
G43	Tool length offset (+)
G43_4	Tool tip point control (type 1)
G43_5	Tool tip point control (type 2)
G44	Tool length offset (-)
G49	Tool length compensation cancel
G52	Local coordinate system setting
G53	Machine coordinate system selection
G53_1	Tool-axis direction control
G54	Select Work Coordinate System #1
G54_1	Additional workpiece coordinate systems
G54_2	Selection of fixture offset
G54_4	Workpiece setup error correction
G55	Select Work Coordinate System #2
G56	Select Work Coordinate System #3
G57	Select Work Coordinate System #4
G58	Select Work Coordinate System #5
G59	Select Work Coordinate System #6
G61_1	High-accuracy mode (Geometry compensation)
G65	Subprogram call with arguments
G66	Modal Subprogram set with arguments
G66_1	Modal Subprogram set with arguments
G67	Cancel modal subprogram call
G68	3-dimensional coordinate system conversion
G68_2	Inclined-plane machining ON
G68_3	Inclined-plane machining (by specifying tool-axis direction) ON
G68_4	Incremental coordinate system establishment for inclined-plane machining
G69	3-D coordinate conversion OFF
G73	Fixed cycle (High-speed deep-hole drilling)
G74	Fixed cycle (Reverse tapping)
G75	Fixed cycle (Boring 1)
G76	Fixed cycle (Boring 2)
G77	Fixed cycle (Back spot facing)
G78	Fixed cycle (Boring 3)
G79	Fixed cycle (Boring 4)

G-Codes	Description
G80	Fixed cycle OFF
G81	Fixed cycle (Spot drilling)
G82	Fixed cycle (Drilling)
G83	Fixed cycle (Deep-hole drilling)
G84	Fixed cycle (Tapping)
G84_2	Fixed cycle (Synchronous tapping)
G84_3	Fixed cycle (Synchronous reverse tapping)
G85	Fixed cycle (Reaming)
G86	Fixed cycle (Boring 5)
G87	Fixed cycle (Back boring)
G88	Fixed cycle (Boring 6)
G89	Fixed cycle (Boring 7)
G90	Absolute programming
G91	Incremental programming
G92	Spindle Speed Maximum RPM Limit
G94	Feed per minute (asynchronous)
G95	Feed per revolution (synchronous)
G96	Turns on constant surface speed
G97	Cancels constant surface speed
G98	Initial point level return in fixed cycles
G99	R-point level return in fixed cycles
G270	Finishing Cycle
G271	Longitudinal rough cutting cycle
G272	Transverse roughing cycle (leaving finishing allowance)
G273	Formed material rough cutting cycle
G274	Longitudinal cut-off cycle
G275	Transverse cut-off cycle
G276	Compound thread cutting cycle
G290	Longitudinal turning cycle
G292	Thread Cutting
G294	End Facing Cycle
M-Codes	Description
M0	Programmed stop
M1	Optional stop
M2	Program end
M3	Start of forward milling spindle rotation
M4	Start of backward milling spindle rotation
M5	Stop of milling spindle rotation
M6	Tool Change

M-Codes	Description
M8	Coolant On
M9	Coolant Off
M30	End of program and reset
M98	Subprogram call
M99	Subprogram Return / Loop
M203	Milling tool normal rotation
M204	Milling tool reverse rotation
M205	Milling tool stop

5.10.12. Mitsubishi

5.10.12.1. Mitsubishi Turning

List of G and M-codes for Mitsubishi Turning as of CIMCO Edit 2026.01.09

G-Codes	Description
G0	Rapid Motion Positioning
G1	Linear Interpolation Motion
G2	Circular Interpolation Motion CW
G3	Circular Interpolation Motion CCW
G4	Dwell
G7.1	(G107) Cylindrical interpolation
G8	High speed machining
G10	Programmable data input
G17	XY Plane Selection
G18	XZ Plane Selection
G19	YZ Plane Selection
G20	Select Inches
G21	Select Metric
G28	Return To Machine Zero Point
G30	2nd, 3rd and 4th reference position return
G40	Tool nose compensation cancel
G41	Tool Nose Compensation (TNC) Left
G42	Tool Nose Compensation (TNC) Right
G50	Spindle Speed Maximum RPM Limit
G52	Local coordinate system setting
G53	Basic machine coordinate system selection
G54	Select Work Coordinate System #1
G55	Select Work Coordinate System #2
G56	Select Work Coordinate System #3

G-Codes	Description
G57	Select Work Coordinate System #4
G58	Select Work Coordinate System #5
G59	Select Work Coordinate System #6
G65	User macro call
G70	Finishing Cycle
G71	Longitudinal rough cutting cycle
G72	Face rough cutting cycle
G73	Formed material rough cutting cycle
G74	Face cut-off cycle
G75	Longitudinal cut-off cycle
G76	Compound thread cutting cycle
G76.1	2-part System Synchronous Thread Cutting Cycle I
G76.2	2-part System Synchronous Thread Cutting Cycle II
G80	Canned Cycle Cancel
G81	Drilling Cycle, Spot Drilling
G82	Drilling Cycle, Counter Boring Cycle
G83	Peck Drilling Cycle
G84	Tapping cycle
G85	Boring Cycle Face
G87	Drilling Cycle Side
G88	Tapping Cycle Side
G89	Bore In, Dwell, Bore Out Canned Cycle
G96	Constant surface speed control ON
G97	Constant surface speed control OFF
G107	(G107) Cylindrical interpolation
M-Codes	Description
M0	Programmed stop
M1	Optional stop
M2	End of program
M3	Spindle CW
M4	Spindle CCW
M5	Spindle Stop
M8	Coolant On
M9	Coolant Off
M13	Spindle ON clockwise/Coolant ON
M14	Spindle ON counterclockwise/Coolant ON
M23	2nd Spindle CW
M24	2nd Spindle CCW
M25	2nd Spindle Stop

M-Codes	Description
M30	End of program and reset
M98	Subprogram call
M99	Subprogram end
M198	External subprogram call

5.10.12.2. Mitsubishi Milling

List of G and M-codes for Mitsubishi Milling as of CIMCO Edit 2026.01.09

G-Codes	Description
G0	Positioning (rapid traverse)
G1	Linear interpolation (cutting feed)
G2	Circular interpolation CW
G3	Circular interpolation CCW
G4	Dwell (Time-based Designation)
G10	Programmable data input
G17	XY Plane Selection
G18	XZ Plane Selection
G19	YZ Plane Selection
G20	Inch command
G21	Metric command
G28	Reference position return completed
G30	2nd to 4th reference position return
G34	Special fixed cycle (bolt hole circle)
G35	Special fixed cycle (line at angle)
G36	Special fixed cycle (arc)
G37_1	Special fixed cycle (grid)
G40	Tool radius compensation cancel
G41	Tool radius compensation left
G42	Tool radius compensation right
G43	Tool length compensation +
G43_4	Tool center point control type1 ON
G44	Tool length compensation -
G49	Tool length compensation cancel, Tool center point control cancel
G52	Local coordinate system setting
G53	Basic machine coordinate system selection
G53_1	Tool axis direction control (type 1)
G54	Workpiece coordinate system 1 selection
G54_1	Extended workpiece coordinate system selection
G55	Workpiece coordinate system 2 selection
G56	Workpiece coordinate system 3 selection

G-Codes	Description
G57	Workpiece coordinate system 4 selection
G58	Workpiece coordinate system 5 selection
G59	Workpiece coordinate system 6 selection
G65	Subprogram call with arguments
G68_2	Inclined surface machining command
G69	3-dimensional coordinate conversion mode OFF, Cancel inclined surface machining command
G73	Fixed cycle (stepping cycle)
G74	Fixed cycle (reverse tap)
G76	Fixed cycle (Fine boring)
G80	Fixed cycle cancel
G81	Fixed cycle (drill/spot drill)
G82	Fixed cycle (drill/counter boring)
G83	Fixed cycle (deep drilling/small-diameter deep-hole drilling)
G84	Fixed cycle (tapping)
G85	Fixed cycle (boring)
G86	Fixed cycle (boring)
G87	Fixed cycle (back boring)
G88	Fixed cycle (boring)
G89	Fixed cycle (boring)
G90	Absolute value command
G91	Incremental value command
G92_1	Workpiece Coordinate System Preset
G92	Coordinate System Setting
G94	Feed per minute (asynchronous feed)
G95	Feed per revolution (synchronous feed)
G98	Fixed cycle Initial level return
G99	Fixed cycle R point level return
M-Codes	Description
M0	Program stop
M1	Optional stop
M2	Program end
M3	Start of forward milling spindle rotation
M4	Start of backward milling spindle rotation
M5	Stop of milling spindle rotation
M6	Tool Change
M8	Coolant On
M9	Coolant Off
M30	End of program and reset
M98	Subprogram call

M-Codes	Description
M99	Subprogram end
M198	Subprogram call from SD card

5.10.13. NumeriPath

5.10.13.1. NumeriPath Milling

List of G and M-codes for NumeriPath Milling as of CIMCO Edit 2026.01.09

G-Codes	Description
G0	Positioning (rapid traverse)
G1	Linear interpolation (cutting feed)
G2	Circular interpolation CW or helical interpolation CW
G3	Circular interpolation CW or helical interpolation CCW
G4	Dwell
G17	XY Plane Selection
G18	XZ Plane Selection
G19	YZ Plane Selection
G20	AX plane selection
G21	BY plane selection
G22	CZ plane selection collinear Y
G23	CZ plane selection collinear X
G24	AB plane selection
G25	VW plane - NC contouring head
G40	Tool radius/tool nose radius compensation : cancel, 3-dimensional cutter compensation : cancel
G41	Tool radius/tool nose radius compensation : left, 3-dimensional cutter compensation : left
G42	Tool radius/tool nose radius compensation : right, 3-dimensional cutter compensation : right
G43	Tool radius/tool nose radius compensation : left, 3-dimensional cutter compensation : left
G44	Tool radius/tool nose radius compensation : right, 3-dimensional cutter compensation : right
G50	Adaptive control off
G51	Adaptive control on
G60	Cancel envelopes
G61	Enable envelope 1
G62	Enable envelope 2
G70	Input in inch
G71	Input in mm
G80	Canned cycle cancel
G81	Drill/Bore cycle
G82	Drill/Bore/Dwell cycle
G83	Deep hole drill cycle

G-Codes	Description
G84	Tap cycle
G85	Feed in / Feed out cycle
G86	Bore / Stopped spindle retract cycle
G87	Chip breaker drill cycle
G88	Bore / Orient spindle / Move off center / Retract cycle
G89	Back bore cycle
G90	Absolute programming
G91	Incremental programming
G92	Work Coordinate Systems Shift Value
G94	Feed per minute
G95	Feed per revolution
M-Codes	Description
M0	Programmed stop
M1	Optional stop
M2	End of program
M3	Spindle CW
M4	Spindle CCW
M5	Spindle Stop
M6	Tool Change
M8	Coolant ON - Flood coolant
M9	Coolant Off
M30	End of program and reset

5.10.13.2. NumeriPath Turning

List of G and M-codes for NumeriPath Turning as of CIMCO Edit 2026.01.09

G-Codes	Description
G0	Positioning (rapid traverse)
G1	Linear interpolation (cutting feed)
G2	Circular interpolation CW or helical interpolation CW
G3	Circular interpolation CW or helical interpolation CCW
G4	Dwell
G17	XY Plane Selection
G18	XZ Plane Selection
G19	YZ Plane Selection
G20	AX plane selection
G21	BY plane selection
G22	CZ plane selection collinear Y
G23	CZ plane selection collinear X
G24	AB plane selection

G-Codes	Description
G25	VW plane - NC contouring head
G33	Thread cutting, constant lead
G40	Tool radius/tool nose radius compensation : cancel, 3-dimensional cutter compensation : cancel
G41	Tool radius/tool nose radius compensation : left, 3-dimensional cutter compensation : left
G42	Tool radius/tool nose radius compensation : right, 3-dimensional cutter compensation : right
G43	Tool radius/tool nose radius compensation : left, 3-dimensional cutter compensation : left
G44	Tool radius/tool nose radius compensation : right, 3-dimensional cutter compensation : right
G50	Adaptive control off
G51	Adaptive control on
G60	Cancel envelopes
G61	Enable envelope 1
G62	Enable envelope 2
G70	Input in inch
G71	Input in mm
G80	Canned cycle cancel
G81	Drill/Bore cycle
G82	Drill/Bore/Dwell cycle
G83	Deep hole drill cycle
G84	Tap cycle
G85	Feed in / Feed out cycle
G86	Bore / Stopped spindle retract cycle
G87	Chip breaker drill cycle
G88	Bore / Orient spindle / Move off center / Retract cycle
G89	Back bore cycle
G90	Absolute programming
G91	Incremental programming
G92	Work Coordinate Systems Shift Value
G94	Feed per minute
G95	Feed per revolution
M-Codes	Description
M0	Programmed stop
M1	Optional stop
M2	End of program
M3	Spindle CW
M4	Spindle CCW
M5	Spindle Stop
M6	Tool Change
M8	Coolant ON - Flood coolant
M9	Coolant Off

M-Codes	Description
M30	End of program and reset

5.10.14. OSAI

5.10.14.1. OSAI Milling

List of G and M-codes for OSAI Milling as of CIMCO Edit 2026.01.09

G-Codes	Description
G0	Positioning (rapid traverse)
G1	Linear interpolation (cutting feed)
G2	Circular interpolation CW or helical interpolation CW
G3	Circular interpolation CW or helical interpolation CCW
G4	Dwell
G16	Defined interpolation plane
G17	XY Plane Selection
G18	XZ Plane Selection
G19	YZ Plane Selection
G20	Closes GTL profile
G21	Opens GTL profile
G40	Tool radius/tool nose radius compensation : cancel, 3-dimensional cutter compensation : cancel
G41	Tool radius/tool nose radius compensation : left, 3-dimensional cutter compensation : left
G42	Tool radius/tool nose radius compensation : right, 3-dimensional cutter compensation : right
G70	Input in inch
G71	Input in mm
G72	Point Measurement with Compensation
G73	Hole probing with probe ball radius compensation
G74	Probing for theoretical deviation from point without probe ball radius compensation
G79	Programming referred to machine zero
G80	Disables fixed cycles
G81	Drilling Cycle
G82	Spot Facing Cycle
G83	Deep Drilling Cycle
G84	Tapping Cycle with Transducer
G85	Reaming Cycle (or Tapping by Tapmatic)
G86	Boring cycle
G89	Boring cycle with Spot Facing
G90	Absolute programming
G91	Incremental programming
G92	Work Coordinate Systems Shift Value

G-Codes	Description
G94	Feed per minute
G95	Feed per revolution
G96	Constant surface speed in fpm or mpm
G97	Spindle speed programming in rpm
G99	Deletes G92
M-Codes	Description
M0	Programmed stop
M1	Optional stop
M2	End of program
M3	Spindle CW
M4	Spindle CCW
M5	Spindle Stop
M6	Tool Change
M8	Coolant ON - Flood coolant
M9	Coolant Off
M13	Spindle ON clockwise/Coolant ON
M14	Spindle ON counterclockwise/Coolant ON
M19	Spindle Stop and Angular Orientation
M30	End of program and reset

5.10.15. Okuma

5.10.15.1. Okuma Turning

List of G and M-codes for Okuma Turning as of CIMCO Edit 2026.01.09

G-Codes	Description
G0	Positioning
G1	Linear interpolation
G2	Circular interpolation - Helical cutting (CW)
G3	Circular interpolation - Helical cutting (CCW)
G4	Dwell
G15	Selection of work coordinate system (Modal)
G16	Selection of work coordinate system (One-shot)
G17	XY Plane Selection
G18	Plane selection: ZX
G19	YZ Plane Selection
G20	Home position return command
G31	Fixed Thread Cutting Cycle : longitudinal
G32	Fixed Thread Cutting Cycle: Transversal

G-Codes	Description
G33	Fixed Thread Cutting Cycle : longitudinal
G34	Non-Fixed Thread Cutting Cycle : increasing
G35	Non-Fixed Thread Cutting Cycle : decreasing
G40	Cutter radius compensation (G41, G42) cancel
G41	Cutter radius compensation, left
G42	Cutter radius compensation, right
G50	Zero shift/Spindle Speed Maximum RPM Limit
G69	Longitudinal taper shape cutting cycle
G70	End face taper shape cutting cycle
G71	Longitudinal thread cutting cycle (compound/multiple pass)
G72	Transversal thread cutting cycle (compound/multiple pass)
G73	Longitudinal Grooving Fixed Cycle
G74	Transversal grooving/drilling fixed cycle
G75	Automatic C-chamfering
G76	Automatic rounding
G77	Right hand tapping cycle
G78	Left hand tapping cycle
G80	End of contour definition (LAP)
G81	Start of contour definition, longitudinal (LAP)
G82	Start of contour definition, transversal (LAP)
G83	Start of blank shape definition (LAP4 only)
G84	Change of rough turning conditions, bar turning (LAP)
G85	Bar turning cycle (LAP)
G86	Copy turning cycle (LAP)
G87	Finish turning cycle (LAP)
G90	Absolute dimensioning mode
G91	Incremental dimensioning mode
G94	Feed Per Minute Mode
G95	Feed Per Revolution
G96	Turns on constant surface speed
G97	Cancel constant surface speed
G101	Linear interpolation in contour generation
G102	Circular interpolation in contour generation (Face) (CW)
G103	Circular interpolation in contour generation (Face) (CWW)
G136	End of coordinate conversion or Y-axis mode OFF
G137	Start of coordinate conversion
G138	Y-axis mode ON
G178	Forward tapping cycle
G179	Reverse tapping cycle

G-Codes	Description
G180	Cancel of Fixed Cycle
G181	Drilling Cycle
G182	Boring Cycle
G183	Deep hole Drilling Cycle
G184	Tapping cycle
G185	Longitudinal compound thread cutting cycle
G186	Transversal compound thread cutting cycle
G187	Longitudinal straight compound thread cutting cycle
G188	Transversal compound straight thread cutting cycle
G189	Reaming/Boring Cycle
M-Codes	Description
M0	Program stop
M1	Optional stop
M2	End of program
M3	Spindle CW
M4	Spindle CCW
M5	Spindle Stop
M8	Coolant On
M9	Coolant Off
M12	M-tool Spindle Stop
M13	M-tool Spindle CW
M19	Orient Spindle
M22	Chamfering OFF
M23	Chamfering ON
M26	Cancellation of M27, parallel to Z-axis
M27	Parallel to X-axis ON
M30	End of program and reset
M32	Straight infeed along thread face (on left face)
M33	Zigzag infeed
M73	Infeed pattern 1
M74	Infeed pattern 2
M75	Demin. cuts even cross section
M83	Chuck clamp
M84	Chuck unclamp
M85	No return to the cutting starting point after the completion of rough turning cycle
M88	Air blower OFF
M89	Air blower ON
M248	Sub spindle chuck clamp
M249	Sub spindle chuck unclamp

M-Codes	Description
M254	Program stop

5.10.15.2. Okuma Milling

List of G and M-codes for Okuma Milling as of CIMCO Edit 2026.01.09

G-Codes	Description
G0	Rapid interpolation
G1	Linear interpolation
G2	Circular interpolation - Helical cutting (CW)
G3	Circular interpolation - Helical cutting (CCW)
G4	Dwell
G10	Cancel of G11
G11	Parallel and rotational shift of coordinate system
G15	Selection of work coordinate system (Modal)
G16	Selection of work coordinate system (One-shot)
G17	Plane selection: XY
G18	Plane selection: ZX
G19	YZ Plane Selection
G20	Inch input confirmation
G21	Metric input confirmation
G30	Positioning to home position
G40	Cutter radius compensation (G41, G42) cancel
G41	Cutter radius compensation, left
G42	Cutter radius compensation, right
G53	Tool length offset cancel
G56	Tool length offset, Z-axis
G71	Designation of return level for M53
G73	Fixed cycle, High speed drilling cycle
G74	Fixed cycle, Reverse tapping cycle
G75	Fixed cycle, Step & pick cycle
G76	Fixed cycle, Fine boring
G79	Fixed cycle, Variable pitch cycle
G80	Fixed cycle, Modal cancel
G81	Fixed cycle, Spot boring
G82	Fixed cycle, Counter boring
G83	Fixed cycle, Deep hole drilling cycle
G84	Fixed cycle, Tapping cycle
G85	Fixed cycle, Boring cycle
G86	Fixed cycle, Boring cycle
G87	Fixed cycle, Back boring cycle

G-Codes	Description
G88	Fixed cycle, Multi-step boring cycle
G89	Fixed cycle, Boring cycle
G90	Absolute dimensioning mode
G91	Incremental dimensioning mode
G94	Feed per minute mode
G95	Feed per revolution mode
G131	High-speed contouring control ON
G169	Tool length offset at cutting edge ON
G170	Tool length offset at cutting edge and in axial direction cancel
G272	Fixed cycle; Deep hole tapping and reverse tapping
G273	Fixed cycle; High-speed deep hole tapping and reverse tapping
G274	Fixed cycle; Synchronized tapping, reverse tapping
G281	Fixed cycle; Small diameter and deep hole drilling
G282	Fixed cycle; Deep hole synchronized tapping
G283	Fixed cycle; High-speed deep hole synchronized tapping
G284	Fixed cycle; Synchronized tapping
G604	Dynamic fixture offset mode OFF
G605	Dynamic fixture offset mode ON
M-Codes	Description
M0	Program stop
M1	Optional stop
M2	End of program
M3	Spindle CW
M4	Spindle CCW
M5	Spindle Stop
M6	Tool Change
M8	Coolant On
M9	Coolant Off
M15	4th axis CW rotation
M16	4th axis CCW rotation
M30	End of program and reset
M52	Return to upper limit level
M53	Return to specified point level
M54	Return to the point R level
M115	5th axis CW rotation
M116	5th axis CCW rotation

5.10.16. Roeders

5.10.16.1. Roeders Milling

List of G and M-codes for Roeders Milling as of CIMCO Edit 2026.01.09

G-Codes	Description
G0	Linear interpolation in rapid feed
G1	Linear interpolation with feed specification
G2	Circular Interpolation Motion CW
G3	Circular Interpolation Motion CCW
G17	Plane selection XY
G18	Plane selection ZX
G19	Plane selection YZ
G40	Deactivating radius correction
G41	2D radius correction to the left of the contour
G42	2D radius correction to the right of the contour
G70	Dimensions specified in inches
G71	Dimensions specified in millimeters
G90	Absolute dimensions
G91	Incremental dimensions

M-Codes	Description
M3	Spindle CW
M5	Spindle Stop
M8	Turn spray cooling on
M9	Turn spray cooling off
M30	End of program

5.10.17. Siemens

5.10.17.1. Siemens Turning

List of G and M-codes for Siemens Turning as of CIMCO Edit 2026.01.09

G-Codes	Description
G0	Command for the activation of rapid traverse motion
G1	Command for the activation of linear interpolation
G2	Command for the activation of clockwise circular interpolation
G3	Command for the activation of counter-clockwise circular interpolation
G4	Dwell
G17	Working plane X/Y
G18	Working plane Z/X

G-Codes	Description
G19	Working plane Y/Z
G25	Lower spindle speed limit
G26	Upper spindle speed limit
G33	Thread cutting with constant lead
G40	Tool nose compensation cancel
G41	Tool radius compensation left
G42	Tool radius compensation right
G53	Machine coordinate system setting
G54	Call of the 1st settable zero offset
G55	Call of the 2nd settable zero offset
G56	Call of the 3rd settable zero offset
G57	Call of the 4th settable zero offset
G58	Absolute programmable work offset
G59	Additive programmable work offset
G63	Tapping with compensating chuck
G70	Activation of the inch measuring system
G71	Activation of the metric measuring system
G74	Search for reference
G75	Fixed point approach
G90	Command for the activation of modal absolute dimensions
G91	Command for the activation of modal incremental dimensions
G93	Path feed type: Inverse-time feedrate [rpm]
G94	Path feed type: Linear feedrate [mm/min], [inch/min] or [degrees/min]
G95	Path feed type: Revolutional feedrate [mm/revolution] or [inch/revolution]
G96	Constant cutting rate with feedrate type G95: ON
G97	Deactivate constant cutting rate with feedrate type G95
G153	Machine coordinate system setting
G450	Transition circle, radius compensation corner behaviour
G451	Intersection of equidistances, radius compensation corner behaviour
G500	Deactivation of the current settable zero offset
G505	Call of the 5th settable zero offset
G506	Call of the 6th settable zero offset
G507	Call of the 7th settable zero offset
G508	Call of the 8th settable zero offset
G509	Call of the 9th settable zero offset
G510	Call of the 10th settable zero offset
G511	Call of the 11th settable zero offset
G512	Call of the 12th settable zero offset
G513	Call of the 13th settable zero offset

G-Codes	Description
G514	Call of the 14th settable zero offset
G515	Call of the 15th settable zero offset
G516	Call of the 16th settable zero offset
G517	Call of the 17th settable zero offset
G518	Call of the 18th settable zero offset
G519	Call of the 19th settable zero offset
G520	Call of the 20th settable zero offset
G521	Call of the 21th settable zero offset
G522	Call of the 22th settable zero offset
G523	Call of the 23th settable zero offset
G524	Call of the 24th settable zero offset
G525	Call of the 25th settable zero offset
G526	Call of the 26th settable zero offset
G527	Call of the 27th settable zero offset
G528	Call of the 28th settable zero offset
G529	Call of the 29th settable zero offset
G530	Call of the 30th settable zero offset
G531	Call of the 31th settable zero offset
G532	Call of the 32th settable zero offset
G533	Call of the 33th settable zero offset
G534	Call of the 34th settable zero offset
G535	Call of the 35th settable zero offset
G536	Call of the 36th settable zero offset
G537	Call of the 37th settable zero offset
G538	Call of the 38th settable zero offset
G539	Call of the 39th settable zero offset
G540	Call of the 40th settable zero offset
G541	Call of the 41th settable zero offset
G542	Call of the 42th settable zero offset
G543	Call of the 43th settable zero offset
G544	Call of the 44th settable zero offset
G545	Call of the 45th settable zero offset
G546	Call of the 46th settable zero offset
G547	Call of the 47th settable zero offset
G548	Call of the 48th settable zero offset
G549	Call of the 49th settable zero offset
G550	Call of the 50th settable zero offset
G551	Call of the 51th settable zero offset
G552	Call of the 52th settable zero offset

G-Codes	Description
G553	Call of the 53th settable zero offset
G554	Call of the 54th settable zero offset
G555	Call of the 55th settable zero offset
G556	Call of the 56th settable zero offset
G557	Call of the 57th settable zero offset
G558	Call of the 58th settable zero offset
G559	Call of the 59th settable zero offset
G560	Call of the 60th settable zero offset
G561	Call of the 61th settable zero offset
G562	Call of the 62th settable zero offset
G563	Call of the 63th settable zero offset
G564	Call of the 64th settable zero offset
G565	Call of the 65th settable zero offset
G566	Call of the 66th settable zero offset
G567	Call of the 67th settable zero offset
G568	Call of the 68th settable zero offset
G569	Call of the 69th settable zero offset
G570	Call of the 70th settable zero offset
G571	Call of the 71th settable zero offset
G572	Call of the 72th settable zero offset
G573	Call of the 73th settable zero offset
G574	Call of the 74th settable zero offset
G575	Call of the 75th settable zero offset
G576	Call of the 76th settable zero offset
G577	Call of the 77th settable zero offset
G578	Call of the 78th settable zero offset
G579	Call of the 79th settable zero offset
G580	Call of the 80th settable zero offset
G581	Call of the 81th settable zero offset
G582	Call of the 82th settable zero offset
G583	Call of the 83th settable zero offset
G584	Call of the 84th settable zero offset
G585	Call of the 85th settable zero offset
G586	Call of the 86th settable zero offset
G587	Call of the 87th settable zero offset
G588	Call of the 88th settable zero offset
G589	Call of the 89th settable zero offset
G590	Call of the 90th settable zero offset
G591	Call of the 91th settable zero offset

G-Codes	Description
G592	Call of the 92th settable zero offset
G593	Call of the 93th settable zero offset
G594	Call of the 94th settable zero offset
G595	Call of the 95th settable zero offset
G596	Call of the 96th settable zero offset
G597	Call of the 97th settable zero offset
G598	Call of the 98th settable zero offset
G599	Call of the 99th settable zero offset
G700	Activation of the inch measuring system
G710	Activation of the metric measuring system
G961	Constant cutting rate with feedrate type G94: ON
G962	Constant cutting rate with feedrate type G94 or G95: ON
G971	Deactivate constant cutting rate with feedrate type G94
G972	Deactivate constant cutting rate with feedrate type G94 or G95
G973	Deactivate constant cutting rate without activating spindle speed limitation
M-Codes	Description
M0	Programmed stop
M1	Optional stop or spindle settings
M2	End of program or spindle settings
M3	Direction of spindle rotation clockwise for master spindle
M4	Direction of spindle rotation counter-clockwise for master spindle
M5	Spindle stop for master spindle
M6	Tool Change
M17	Subprogram end
M30	End of program and reset

5.10.17.2. Siemens Milling

List of G and M-codes for Siemens Milling as of CIMCO Edit 2026.01.09

G-Codes	Description
G0	Command for the activation of rapid traverse motion
G1	Command for the activation of linear interpolation
G2	Command for the activation of clockwise circular interpolation
G3	Command for the activation of counter-clockwise circular interpolation
G4	Dwell
G17	Working plane X/Y
G18	Working plane Z/X
G19	Working plane Y/Z
G25	Lower spindle speed limit
G26	Upper spindle speed limit

G-Codes	Description
G40	Tool radius compensation deactivation
G41	Tool radius compensation left
G42	Tool radius compensation right
G53	G53 suppresses the settable zero offset and the programmable zero offset non-modally
G54	Call of the 1st settable zero offset
G55	Call of the 2nd settable zero offset
G56	Call of the 3rd settable zero offset
G57	Call of the 4th settable zero offset
G58	Absolute programmable work offset
G59	Additive programmable work offset
G70	Activation of the inch measuring system
G71	Activation of the metric measuring system
G74	Search for reference
G75	Fixed point approach
G90	Command for the activation of modal absolute dimensions
G91	Command for the activation of modal incremental dimensions
G94	Path feed type: Linear feedrate [mm/min], [inch/min] or [degrees/min]
G95	Path feed type: Revolutional feedrate [mm/revolution] or [inch/revolution]
G96	Constant cutting rate with feedrate type G95: ON
G97	Deactivate constant cutting rate with feedrate type G95
G110	Pole programming relative to the last programmed setpoint position
G111	Pole programming relative to zero of current workpiece coordinate system
G112	Pole programming relative to the last valid pole
G153	G153 has the same effect as G53 and also suppresses the entire basic frame
G450	Transition circle, radius compensation corner behaviour
G451	Intersection of equidistances, radius compensation corner behaviour
G500	Deactivation of the current settable zero offset
G505	Call of the 5th settable zero offset
G506	Call of the 6th settable zero offset
G507	Call of the 7th settable zero offset
G508	Call of the 8th settable zero offset
G509	Call of the 9th settable zero offset
G510	Call of the 10th settable zero offset
G511	Call of the 11th settable zero offset
G512	Call of the 12th settable zero offset
G513	Call of the 13th settable zero offset
G514	Call of the 14th settable zero offset
G515	Call of the 15th settable zero offset
G516	Call of the 16th settable zero offset

G-Codes	Description
G517	Call of the 17th settable zero offset
G518	Call of the 18th settable zero offset
G519	Call of the 19th settable zero offset
G520	Call of the 20th settable zero offset
G521	Call of the 21th settable zero offset
G522	Call of the 22th settable zero offset
G523	Call of the 23th settable zero offset
G524	Call of the 24th settable zero offset
G525	Call of the 25th settable zero offset
G526	Call of the 26th settable zero offset
G527	Call of the 27th settable zero offset
G528	Call of the 28th settable zero offset
G529	Call of the 29th settable zero offset
G530	Call of the 30th settable zero offset
G531	Call of the 31th settable zero offset
G532	Call of the 32th settable zero offset
G533	Call of the 33th settable zero offset
G534	Call of the 34th settable zero offset
G535	Call of the 35th settable zero offset
G536	Call of the 36th settable zero offset
G537	Call of the 37th settable zero offset
G538	Call of the 38th settable zero offset
G539	Call of the 39th settable zero offset
G540	Call of the 40th settable zero offset
G541	Call of the 41th settable zero offset
G542	Call of the 42th settable zero offset
G543	Call of the 43th settable zero offset
G544	Call of the 44th settable zero offset
G545	Call of the 45th settable zero offset
G546	Call of the 46th settable zero offset
G547	Call of the 47th settable zero offset
G548	Call of the 48th settable zero offset
G549	Call of the 49th settable zero offset
G550	Call of the 50th settable zero offset
G551	Call of the 51th settable zero offset
G552	Call of the 52th settable zero offset
G553	Call of the 53th settable zero offset
G554	Call of the 54th settable zero offset
G555	Call of the 55th settable zero offset

G-Codes	Description
G556	Call of the 56th settable zero offset
G557	Call of the 57th settable zero offset
G558	Call of the 58th settable zero offset
G559	Call of the 59th settable zero offset
G560	Call of the 60th settable zero offset
G561	Call of the 61th settable zero offset
G562	Call of the 62th settable zero offset
G563	Call of the 63th settable zero offset
G564	Call of the 64th settable zero offset
G565	Call of the 65th settable zero offset
G566	Call of the 66th settable zero offset
G567	Call of the 67th settable zero offset
G568	Call of the 68th settable zero offset
G569	Call of the 69th settable zero offset
G570	Call of the 70th settable zero offset
G571	Call of the 71th settable zero offset
G572	Call of the 72th settable zero offset
G573	Call of the 73th settable zero offset
G574	Call of the 74th settable zero offset
G575	Call of the 75th settable zero offset
G576	Call of the 76th settable zero offset
G577	Call of the 77th settable zero offset
G578	Call of the 78th settable zero offset
G579	Call of the 79th settable zero offset
G580	Call of the 80th settable zero offset
G581	Call of the 81th settable zero offset
G582	Call of the 82th settable zero offset
G583	Call of the 83th settable zero offset
G584	Call of the 84th settable zero offset
G585	Call of the 85th settable zero offset
G586	Call of the 86th settable zero offset
G587	Call of the 87th settable zero offset
G588	Call of the 88th settable zero offset
G589	Call of the 89th settable zero offset
G590	Call of the 90th settable zero offset
G591	Call of the 91th settable zero offset
G592	Call of the 92th settable zero offset
G593	Call of the 93th settable zero offset
G594	Call of the 94th settable zero offset

G-Codes	Description
G595	Call of the 95th settable zero offset
G596	Call of the 96th settable zero offset
G597	Call of the 97th settable zero offset
G598	Call of the 98th settable zero offset
G599	Call of the 99th settable zero offset
G700	Activation of the inch measuring system
G710	Activation of the metric measuring system
G961	Constant cutting rate with feedrate type G94: ON
G962	Constant cutting rate with feedrate type G94 or G95: ON
G971	Deactivate constant cutting rate with feedrate type G94
G972	Deactivate constant cutting rate with feedrate type G94 or G95
G973	Deactivate constant cutting rate without activating spindle speed limitation
M-Codes	Description
M0	Programmed stop
M1	Optional stop
M2	End of program
M3	Direction of spindle rotation clockwise for master spindle
M4	Direction of spindle rotation counter-clockwise for master spindle
M5	Spindle stop for master spindle
M6	Tool Change
M17	Subprogram end
M30	End of program and reset

6. DNC Setup

This section describes the configuration options in the *DNC Setup* dialog.

The dialog can be opened from the [Transmission](#) menu or the [Setup](#) menu under the Transmission tab.

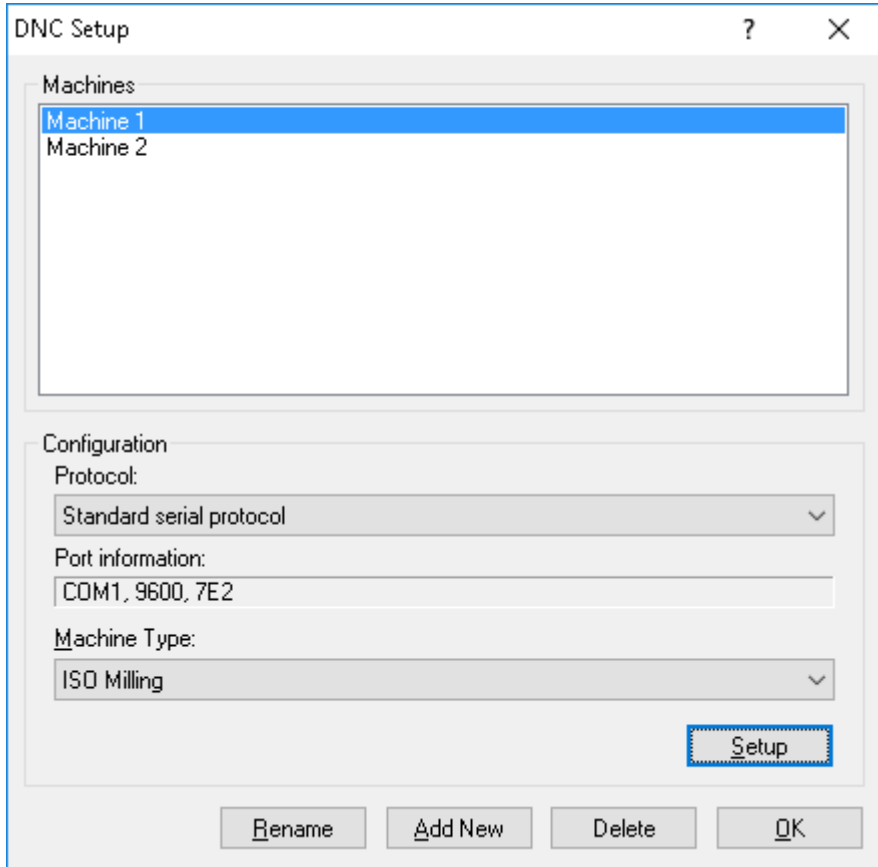

DNC Setup dialog.

Machines

This section shows a list of machines (machine configurations). The options below in the *Configuration* section are specific to the machine selected in this list.

Protocol

Use this dropdown to select the communication protocol for the selected machine.

- For transfers via serial select the [Standard Serial Protocol](#).
- For transfers via FTP select the [FTP Client Protocol](#).

Port information

Shorthand of important connection settings.

For a serial connection the line 'COM1, 9600, 7E2' has the following meaning:

- Port: COM1
- Baud rate: 9600
- Data bits: 7
- Parity: E (even)
- Stop bits: 2

For an FTP connection the line 'cimco@192.168.254.231' has the following meaning:

- Username: cimco
- CNC IP Address: 192.168.254.231

Machine Type

Select the machine type from this list. The machine type is used to determine the default load/save directories, how to detect tool changes etc. during a transfer.

Machine types are configured in the [File Types](#) section in the Editor Setup.

Setup

Click this button to enter the configuration dialog for the selected machine.

Rename

Click this button to rename a machine configuration.

Add New

Click this button to add a new configuration. The following dialog appears:

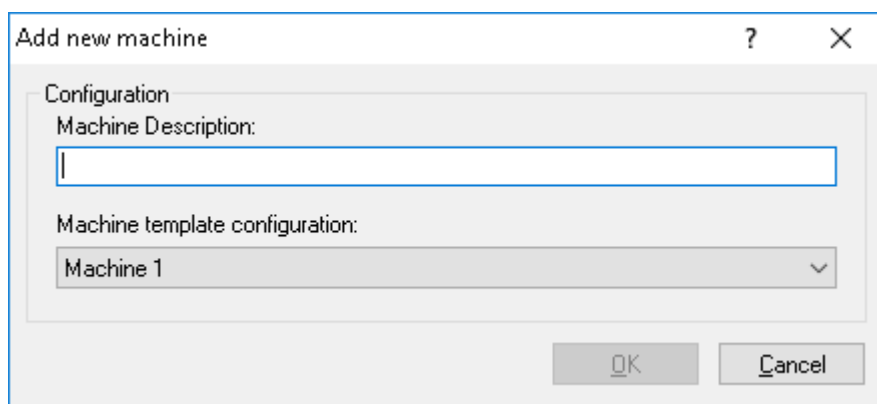

The screenshot shows a dialog box titled "Add new machine" with a question mark icon and a close button (X). Inside the dialog, there is a "Configuration" section. Under "Machine Description:", there is an empty text input field. Below that, under "Machine template configuration:", there is a dropdown menu currently showing "Machine 1". At the bottom right of the dialog, there are two buttons: "OK" and "Cancel".

Add a new machine.

Enter a name and select a machine template to preconfigure the new machine. You can select an existing machine configuration or one of the default templates:

- FTP Client
- Generic Serial Connected CNC
- Okuma Template

Click **OK** to add the new machine or **Cancel** to cancel the operation.

Click this button to delete a configuration. You will be prompted to confirm the deletion.

Click this button to apply the configuration and close the dialog.

6.1. Standard Serial Protocol

This section describes the configuration options in the *Standard Serial Protocol*.

6.1.1. Port

This section allows you to configure the Serial port settings.

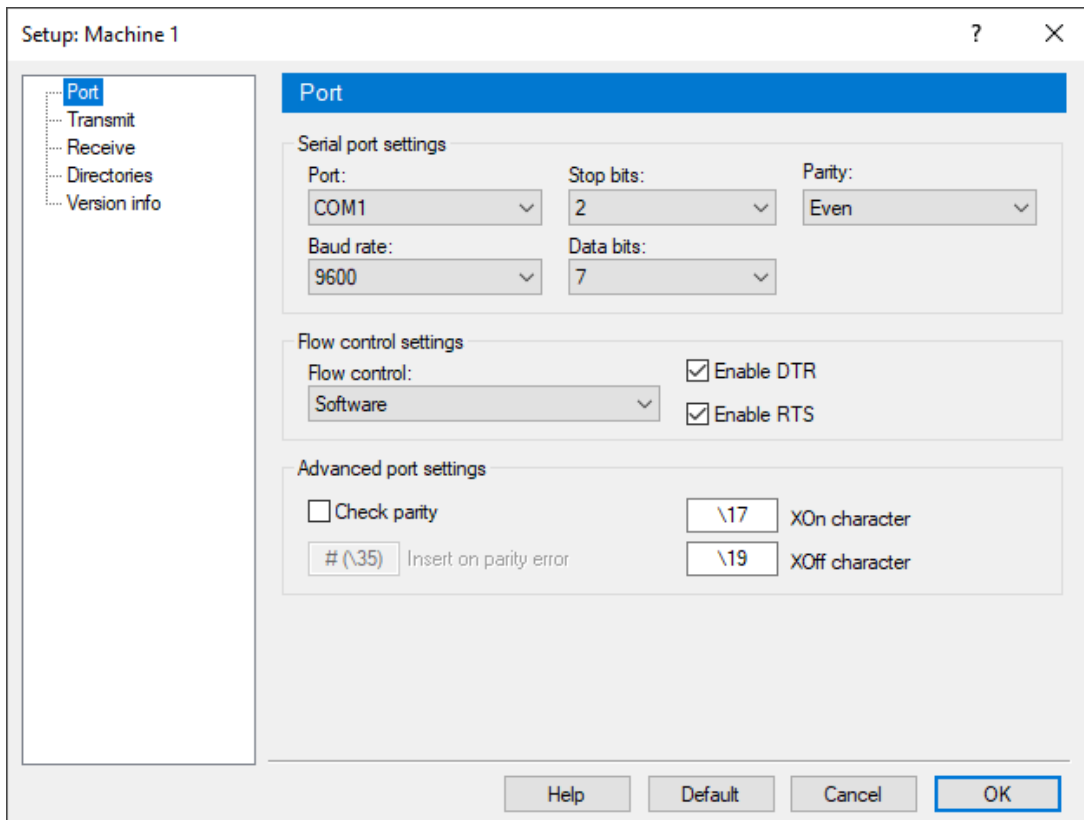

Serial port settings.

Serial Port Settings

Port

List of the serial ports on the local PC. Select the one you wish to use with this machine configuration.

Baud rate

The transmission speed in bits per second. Select the desired Baud rate from the drop-down list.

Stop bits

Select the number of stop bits appended after each character in the communication to separate the data bits.

The number of stop bits required depends on the CNC control. Please refer to the reference manual for more details.

Data bits

Select the number of bits in each character. By default, the 7-bit ASCII code is used for NC data transmission.

Parity

The parity is an error checking method which indicates if a transmission was successful or not, by adding a 'parity bit' (8th bit when using 7-bit ASCII code for data transmission) to ensure the number of bits with the value '1' in a set of bits is *even* or *odd*.

The method can operate in different modes:

- **None:** Is selected when no parity error checking is going to be used.
- **Even** parity: An even number of 1's is used in each character.
- **Odd** parity: An odd number of 1's is used in each character.

Only for special cases (test purposes):

- **Mark** parity: The parity bit is always '1' and the line is 'low'.
- **Space** parity: The parity bit is always '0' and the line is 'high'.

Flow Control Settings

Flow control

The handshake procedure for synchronizing the communication between the computer and the CNC control. There are two types of flow control:

Software handshake uses the XOn/XOff ASCII characters.

Hardware handshake uses the RTS/CTS control lines in the RS-232 communication specifications.

You can select one of the following flow control methods from the dropdown list:

- **None:** No flow control is performed.
 - **Software:** Software handshake is used for the flow control.
 - **Hardware:** Hardware handshake is used for the flow control.
 - **Hardware and Software:** Both Hardware and Software handshakes are used.
-

Enable DTR

Check this box to set DTR high.

Enable RTS

Check this box to set RTS high.

Advanced Port Settings

Check parity

If you want CIMCO Edit 2026 to report parity errors, then mark the *Check parity* box. Every time an error

occurs, the specified character is inserted into the file at the receiving point.

Non standard XOn and XOff characters can be specified.

Insert on parity error

Use this field to specify a character to insert in the received file, if a parity error occurs while receiving data from the remote machine. If the field is left blank, no character is inserted.

XOn character

Use this field to specify the XOn character. If the field is left blank, the standard XOn character is used. If your machine needs a non-standard XOn character, you can specify it here.

XOff character

Use this field to specify the XOff character. If the field is left blank, the standard XOff character is used. If your machine needs a non-standard XOff character, you can specify it here.

You can specify the *XOn*, *XOff*, and *Insert on parity error* characters by entering the ASCII character, i.e. enter \$ to get ASCII character 36, or you can enter the ASCII value like this \36.

6.1.2. Transmit

This section allows you to configure the Transmit settings.

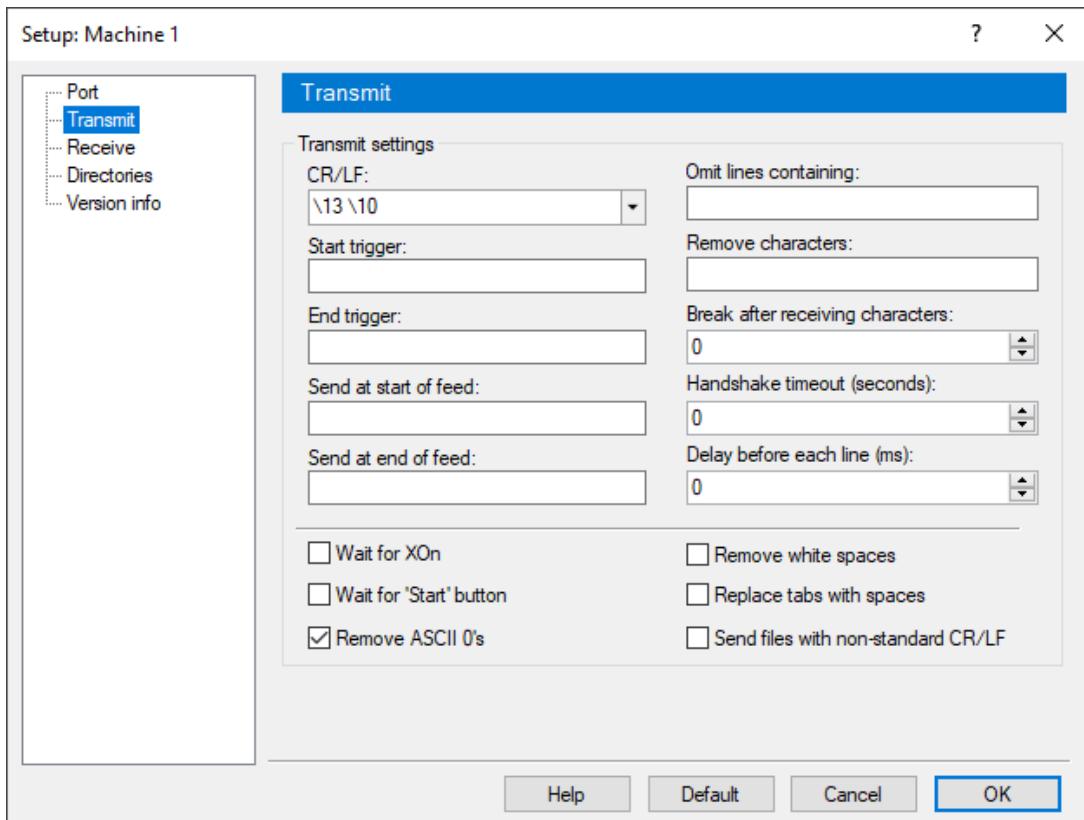

Transmission setup.

Transmit Settings

CR/LF

In this field, you can select the carriage-return or line-feed character(s) from the drop-down list, or you can enter them manually.

ASCII 13 and ASCII 10 have no character representation, so they must be entered as `\13` and `\10` respectively.

Start trigger

Use this field to specify the start trigger. The DNC will start transmitting data from the first line in the file that contains the specified start trigger. If no start trigger is specified, the transmission will start at the beginning of the file.

End trigger

Use this field to specify the end trigger.

The line containing the end trigger is not transmitted.

Send at start of feed

Here, you can specify a character or a string that should be sent at the start of the transmission.

Send at end of feed

Specify a character or a string that should be sent at the end of the transmission.

Omit lines containing

Excludes lines containing one or more selected characters. The consequence of entering anything here is that any line containing one of these characters or strings will not be transmitted.

Remove characters

Use this field to specify characters that should be removed from the transmitted data.

Break after receiving characters

Ends the transmission to the control after the specified number of characters have been sent, even if the program is not finished. If this field is left empty, any incoming characters are ignored.

Handshake timeout (seconds)

The chosen time that CIMCO Edit 2026 should wait after receiving a stop flow signal (XOff and/or CTS Low) from a remote machine before it terminates the connection. If the timeout value is not specified, it will wait until a start flow is received.

Delay before each line (ms)

Specify the time in milliseconds CIMCO Edit 2026 should wait before it begins transmitting a new line.

Wait for XOn

This box is checked if you wish CIMCO Edit 2026 to wait for an Xon before transmitting data. This option is only available if Software handshake is enabled in the port settings.

Wait for 'Start' button
CIMCO Edit 2026 User Guide

Check this field if the transmission should not start until you click the Start button on the transmit status dialog.

Remove ASCII 0's

Check this field if ASCII 0's should be removed from the transmitted data.

Remove white spaces

White spaces (ASCII 32) and tabs (ASCII 9) are removed automatically from the file transmitted to the remote machine.

Replace tabs with spaces

Converts tabs (ASCII 9) to spaces (ASCII 32) before sending the file to the remote machine.

Send files with non-standard CR/LF

Check this field if you wish to send files that contain non-standard linefeed characters like \CR\LF\LF or \CR\CR.

When entering characters in one of the character entry fields, the characters can be entered in two ways: You can enter the characters themselves, like \$* to get ASCII character 36 followed by ASCII 42, or you can enter the ASCII values of the characters like \36\42.

6.1.3. Receive

This section allows you to configure the Receive settings.

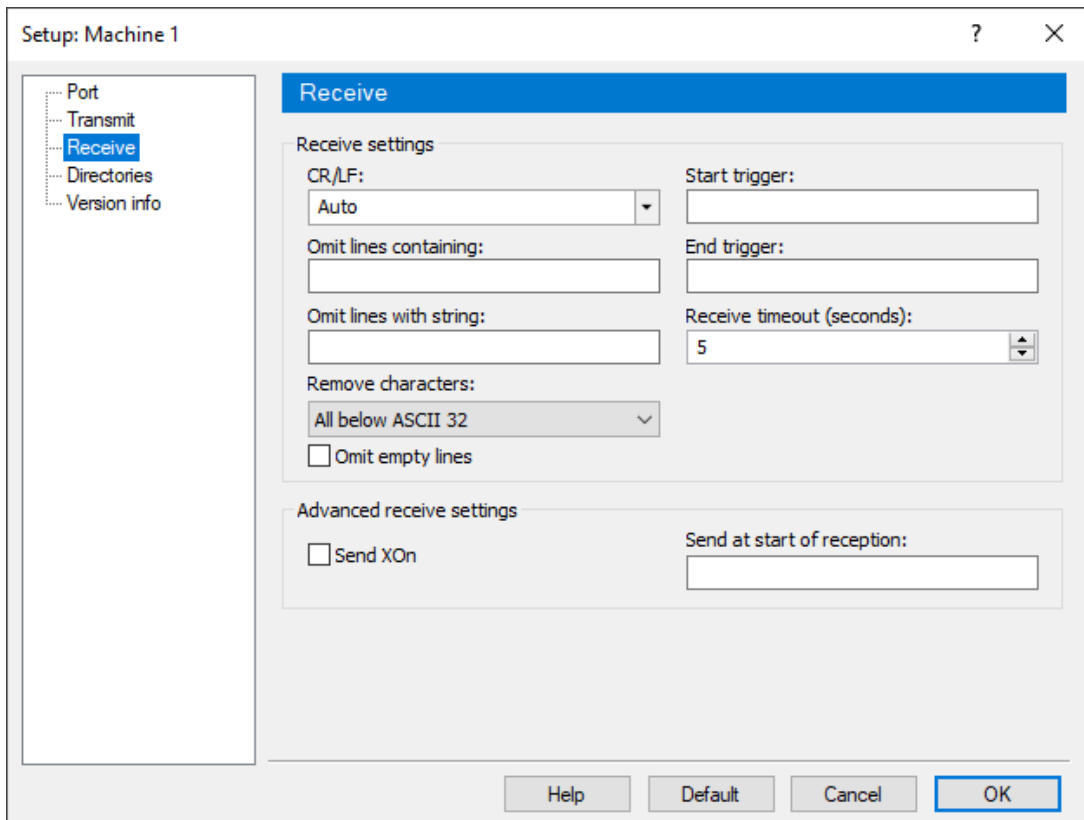

Receive settings.

Receive Settings

CR/LF

Use this field to specify the line feed character(s).

If you select *Auto*, the DNC will try to auto-detect the CR/LF combination used. If the remote machine does not use any of the standard combinations of ASCII 13 and ASCII 10, you must enter the appropriate CR/LF combination manually.

The normal combination is ASCII 13 followed by ASCII 10. ASCII 13 and ASCII 10 have no character representation, so they must be entered as \13 and \10 respectively.

Omit lines containing

Excludes lines containing one or more selected characters. The consequence of entering anything here is that any line containing one of these characters or strings will be discarded when received.

Remove characters

Selected characters will automatically be removed from the received stream. You can select None, ASCII 0 or All below ASCII 32 from the drop-down list if one of those is appropriate.

Omit empty lines

Check this field if empty lines should not be saved.

Start trigger

Start triggers are characters indicating that CIMCO Edit 2026 should start saving incoming data. If no start trigger is used and the field therefore is left empty, CIMCO Edit will start saving at the beginning of the file.

The start trigger is the first sequence of characters received.

End trigger

End triggers are characters indicating that CIMCO Edit 2026 should stop saving incoming data. If no end trigger is used and the field therefore is left empty, CIMCO Edit 2026 will continue to save until the end of the file, where a timeout occurs.

The end trigger is the last sequence of characters received.

Receive timeout in seconds

Indicates the time delay after the last character has been received from the remote machine, until the computer concludes that the receiving operation is finished. If no end trigger is specified, you should specify a value here, or you will have to stop the receive process manually from the receive status dialog.

Advanced Receive Settings

Send XOn

When this field is checked, the DNC will send an XOn character when it is ready to receive data.

Send at start of reception

Specify a string that should be sent to the CNC when a receive operation is started.

When entering characters in one of the character entry fields, the characters can be entered in two ways: You can enter the characters themselves, like \$* to get ASCII character 36 followed by ASCII 42, or you can enter the ASCII values of the characters like \36\42.

6.1.4. Directories

This section allows you to configure the Directories settings.

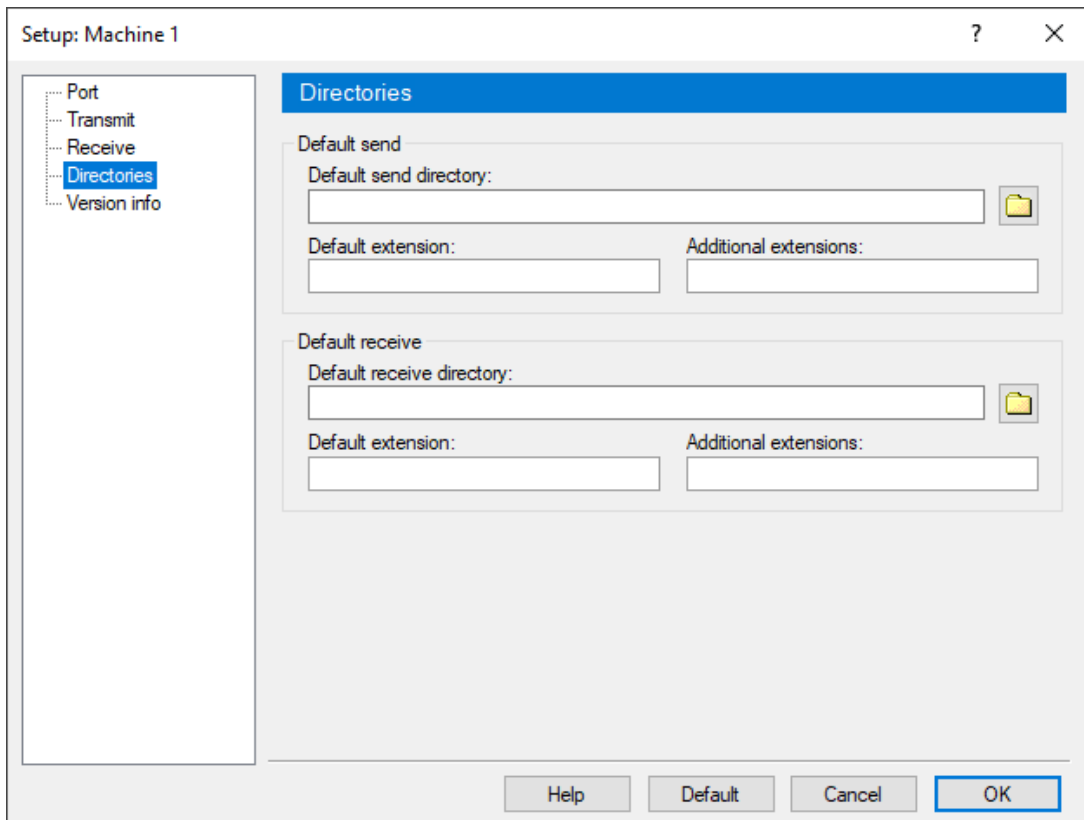

Transmit and Receive directories setup.

Default Send

Default send directory

Specify the default send path in this field, or click on the folder icon  to the right to select a directory.

Default extension

Use this field to specify the default extension of files to be sent.

Additional extensions

Use this field to specify additional extensions for files to be sent.

Default Receive

Default receive directory

Specify the default receive directory, or click on the folder icon  to the right to select a directory.

Default extension

Use this field to specify the default extension for received files.

Additional extensions

Use this field to specify additional extensions for received files.

6.1.5. Version Info

This section allows you to see the version of the Standard Serial Protocol.

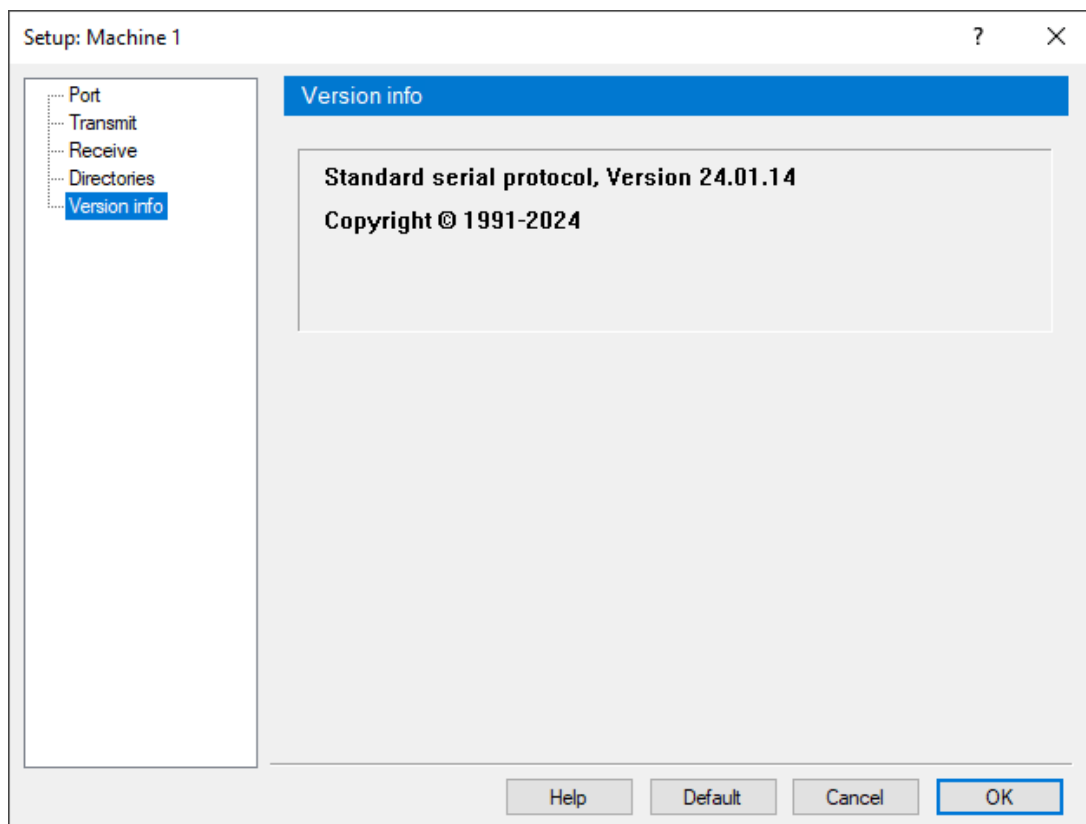

Version info.

6.2. FTP Client Protocol

This section describes the configuration options in the *FTP Client Protocol*.

6.2.1. Port

This section allows you to configure the FTP port settings.

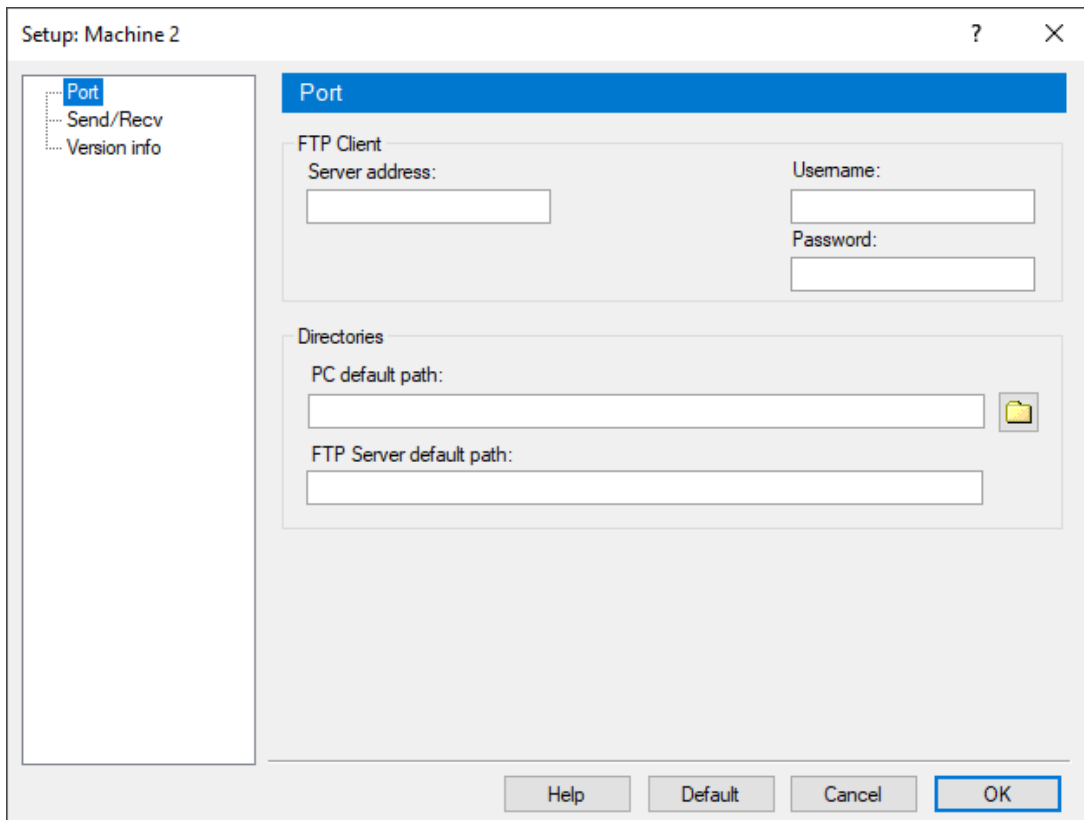

Port settings.

FTP Client

Server address

Use this field to specify the IP address of the FTP server. Example 127.0.0.1.

Username

Use this field to specify the username used for the client connection.

Password

Use this field to specify the username used for the client connection.

Directories

PC default path

Use this field to specify the default path for the PC side files. Leaving this empty will result in default path C:\ being used.

abc **FTP server default path**

Use this field to specify the default path on the FTP server side. Path should be FTP compliant format: /[DIR] or /[DIR]/. Path is written in absolute path from FTP server root.

6.2.2. Send/Receive

This section allows you to configure the FTP send and receive settings.

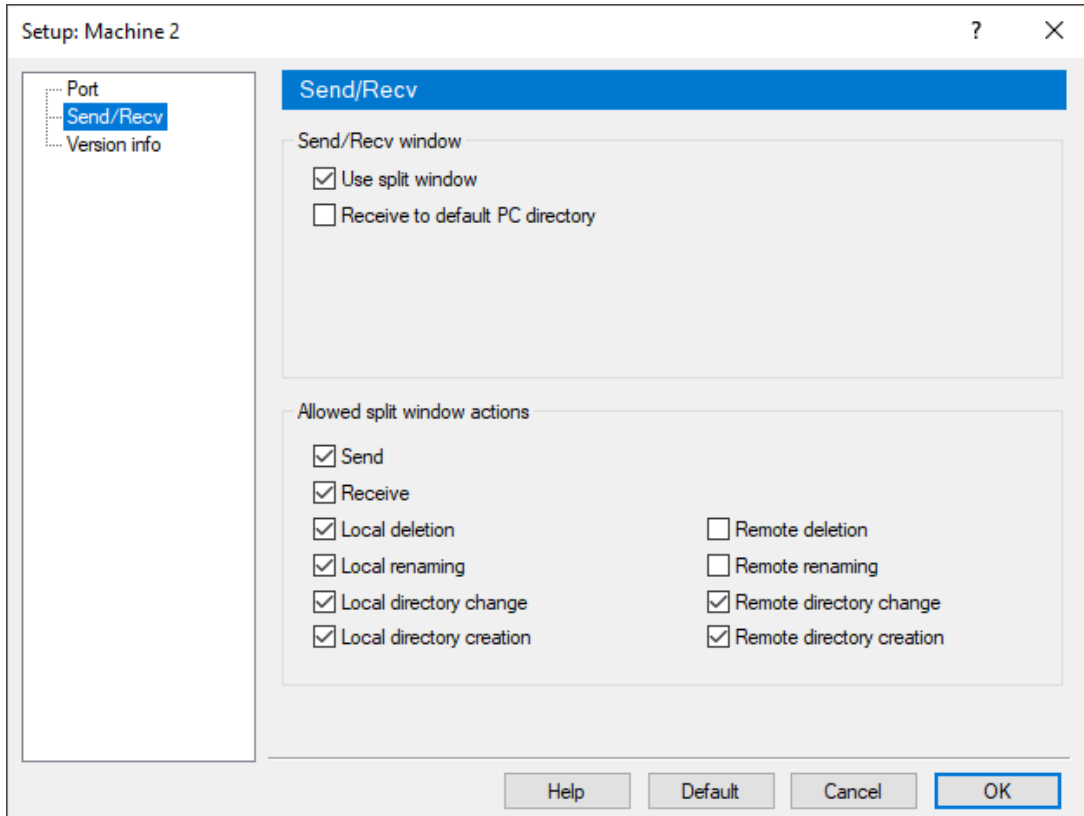

Transmission setup.

Send/Receive window

Use split window

Check this to use a split window when sending and receiving files. The split window is only used if no files is specified when starting send operation. The split window is always used when receiving file from FTP server.

Receive to default PC directory

Check this to always receive files from the FTP server to the default local directory.

Allowed split window actions

Send

Check this to allow the FTP Client to send files to the FTP Server.

Receive

Check this to allow the FTP Client to receive files from the FTP Server.

Local deletion

Check this to allow the split window to delete files and folders on local side.

Local renaming

Check this to allow the split window to rename files and folders on the local side.

Local directory change

Check this to allow the split window to change directory on the local side.

Local directory creation

Check this to allow the split window to create directories on the local side.

Remote deletion

Check this to allow the split window to delete files and folders on the FTP server.

Remote Renaming

Check this to allow the split window to rename files and folders on the FTP server.

Remote directory change

Check this to allow the split window to change directory on the FTP server. If this is disabled, only the default FTP server directory is listed. No folders will be shown in file list.

Remote directory creation

Check this to allow the split window to create directories on the FTP server.

6.2.3. Version Info

This section allows you to see the version of the FTP Client Protocol.

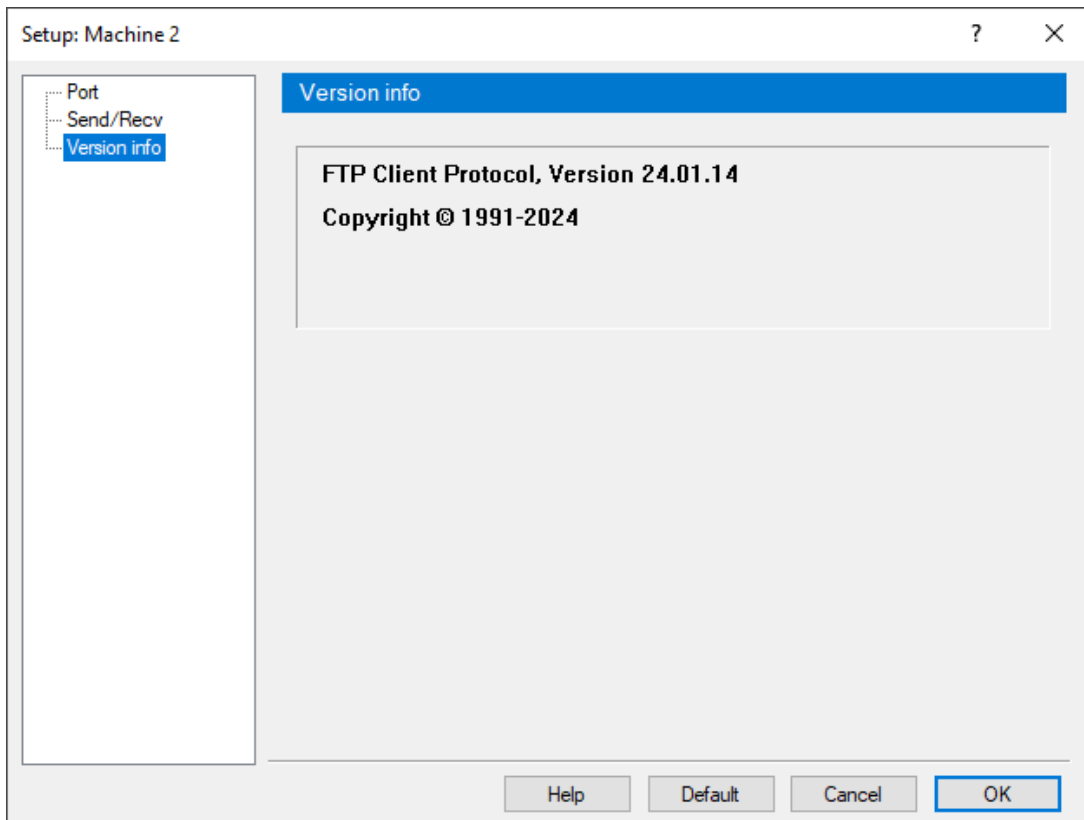

Version info.

7. Editor Setup

This section describes the configuration options in CIMCO Edit.

The Editor Setup dialog consists of two main areas. On the left, you will find the navigation menu that allows you to access different sections. On the right, the configuration settings for the chosen section are displayed.

Use the search bar at the top of the navigation menu to quickly filter through the sections.

At the top of the dialog, you can use the ? icon to get information about most options. Simply click the icon and then click on an option to see a short description.

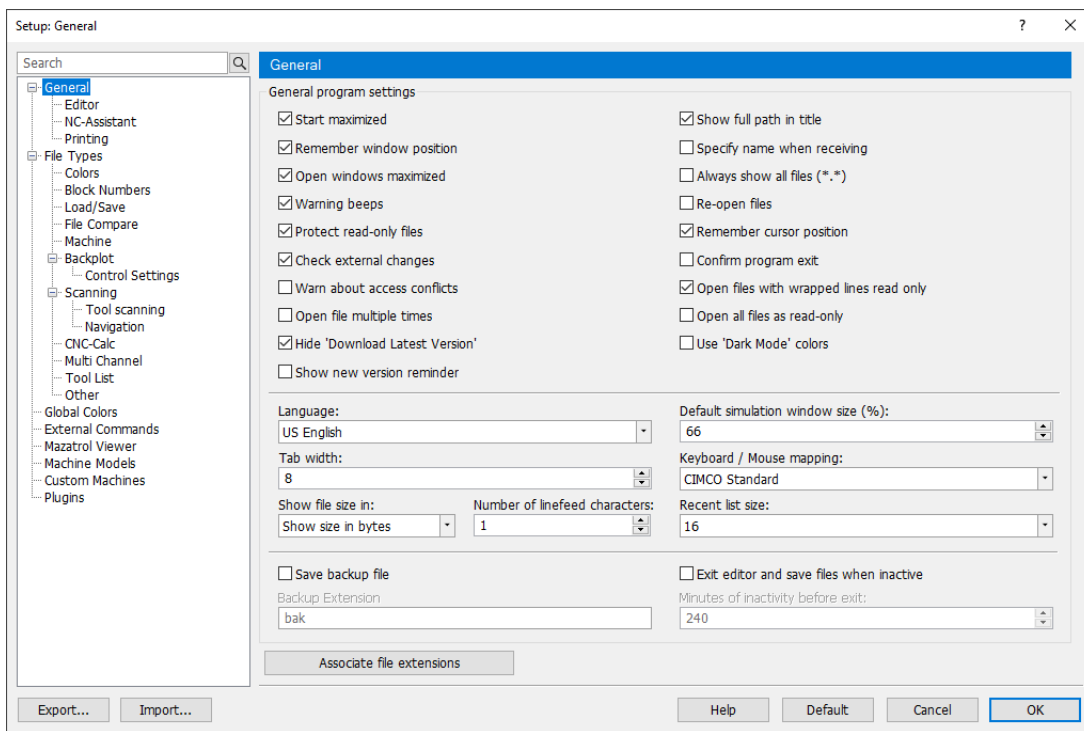

Setup dialog.

General Dialog Buttons

At the bottom of the Editor Setup dialog you will find the following buttons.

Export

Click this button to export the entire CIMCO Edit configuration to a .zip file. This can be used as a backup or for setting up CIMCO Edit on other PCs.

Import

Click this button to import a configuration. Please note that you will need to restart CIMCO Edit to apply the new configuration.

Help

Click this button to open the [Help dialog](#).

Default

Click this button to reset CIMCO Edit to its default settings.

Cancel

Click this button to close the Editor Setup dialog without applying any changes.

OK

Click this button to close the Editor Setup dialog and apply the changes you have made.

7.1. General

The *General* section allows you to configure general settings.

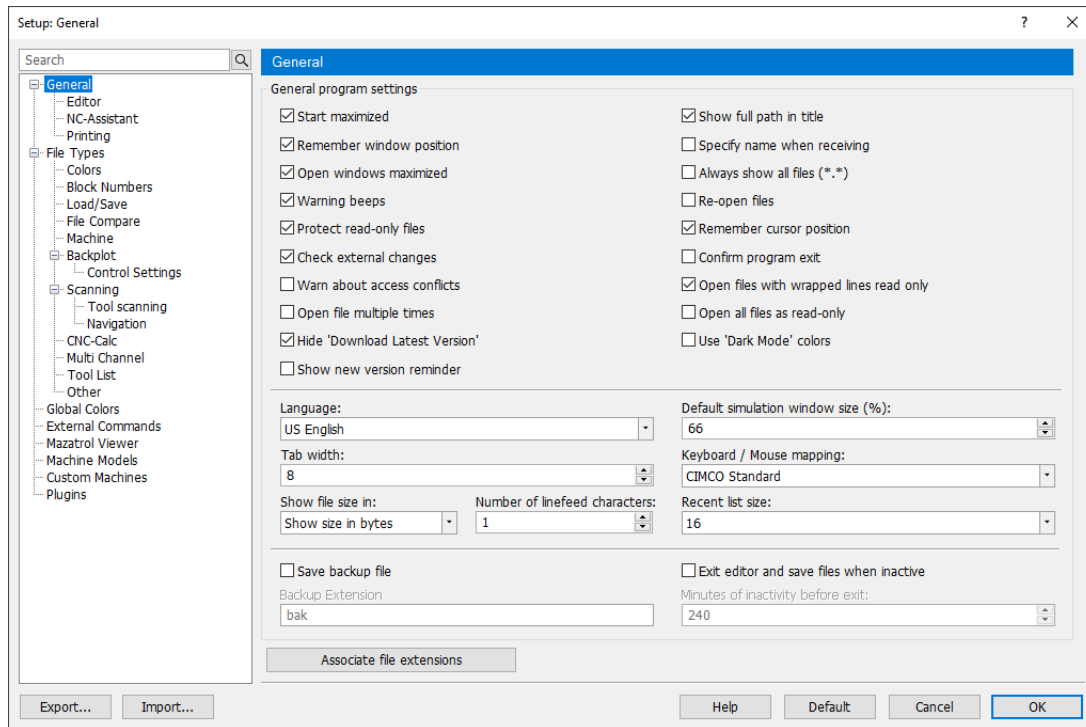

General program settings.

General Program Settings

Start maximized

Select this option to make the program window start maximized.

Remember window position

Select this option to make the programs start at the size and position where it was last opened.

Open windows maximized

Select this option to open files/documents maximized.

Warning beeps

Select this option to enable warning beeps. Note that this will not change the system sounds settings in Windows.

Protect read-only files

Select this option to prevent read-only files from editing.

Check external changes

Select this option to enable CIMCO Edit to monitor for any modifications made to files externally. Should a file be altered outside of the editor, you will be prompted with the choice to reload it.

Warn about access conflicts

When this option is checked, CIMCO Edit will warn you if another instance of CIMCO Edit opens a file that you have open. The other editor will also display a warning that you are using the file.

Only instances of CIMCO Edit trigger these warnings. This function relies on hidden files, so permissions must be either *Read* or *Full*. If CIMCO Edit can create but not delete files, hidden files will accumulate.

Open file multiple times

Select this option if you want to be able to open the same file in more than one window in the editor.

Hide 'Download Latest Version'

Select this option to hide the 'Download Latest Version' link from the Help menu. Note that you must restart the editor after changing this option.

Show new version reminder

Select this option to show a reminder on start up if a new version of CIMCO Edit is available.

Show full path in title

Select this option to show the full path of files in the window title.

Specify name when receiving

Select this option if you wish to specify a filename when using the Transmission tab option *Receive file and open in editor*.

Always show all files (*.*)

Select this option if the file dialog should always show all files.

Re-open files

Select this option to re-open files from the last session when the program is started.

Remember cursor position

Select this option to place the cursor at the position where it was when the file was last opened.

Confirm program exit

Select this option to always confirm when exiting.

Open files with wrapped lines read only

Select this option to have files containing lines longer than 1024 characters opened as read-only, this ensures that the files are not corrupted.

Open all files as read-only

Select this option to open all files as read-only to prevent editing.

Use 'Dark Mode' colors

Select this option to enable 'Dark Mode'.

Language

Use this dropdown to select the language to be used in CIMCO Edit. After changing language, the editor must be restarted.

The following languages are currently available:

- Chinese
- Czech
- Danish
- Dutch
- English (US)
- Estonian
- Finnish
- French
- German
- Hungarian
- Italian

- Japanese
- Korean
- Polish
- Portuguese
- Romanian
- Russian
- Spanish
- Swedish
- Taiwanese
- Thai
- Turkish

Tab width

Use this field to specify the tab width in characters.

Show file size in

Use this dropdown to select how the file size should be displayed in the status bar. The file size can be shown in bytes, in meter, or in feet.

Number of linefeed characters

Use this field to specify how many line feed characters that should be used to calculate the file size shown in the status bar.

Example: If you specify a value of 2, and the file contains 12 lines, 24 bytes will be added to the file size shown in the status bar.

Default simulation window size

Use this field to change the default size of the simulation window in percent of the screen size. The default value is 66 %. Decrease this value to show NC files with long program lines, or increase the value to enlarge the simulation window.

You can resize the Backplot window between 10-90% of default value 66%.

Keyboard/ Mouse Mapping

Use this dropdown to select the keyboard mapping.

Recent list size

Use this dropdown to specify the number of files shown in the *Recent List*.

Save backup file

Select this option to backup the previous version of a file when saving. By default backup versions will get the extension .bak.

Backup Extension

Use this field to set the extension of backup files.

Exit editor and save files when inactive

Check this field to exit editor and save files when inactive, use the field *Minutes of inactivity before exit* to specify the duration before exit.

Associate file extensions

Click this button to associate file extensions (.NC,.H, etc.) with CIMCO Edit, overwriting the current association.

When you click this button, CIMCO Edit re-associates all the extensions defined for each *File Type* under [Load/Save](#).

7.1.1. Editor Settings

The *Editor* section allows you to configure the general look and behaviour when editing documents such as NC programs.

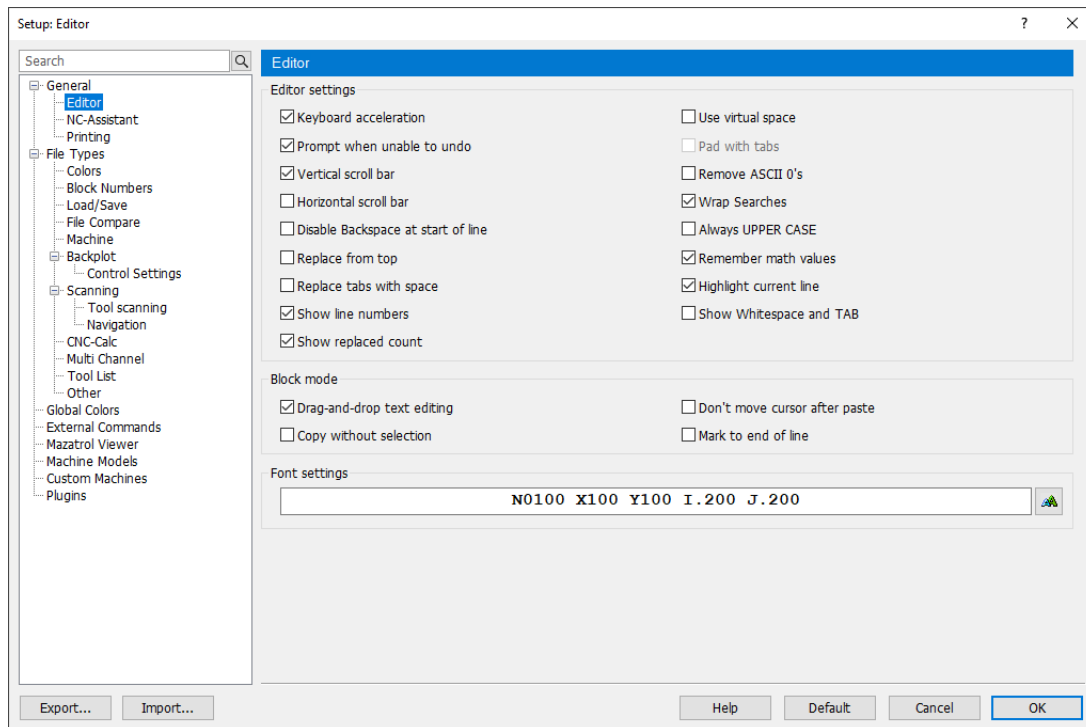

Editor settings.

Editor settings

Keyboard acceleration

Select this option to enable the keyboard cursor to move faster.

Prompt when unable to undo

When this is enabled, you will be told when you are about to do something (such as renumbering a large file) which cannot be undone. If this is disabled, no warning will appear.

Vertical scroll bar

Select this option to enable a vertical scroll bar.

Horizontal scroll bar

Select this option to enable a horizontal scroll bar.

Disable Backspace at start of line

Select this option to prevent that lines are joined by using the backspace key.

Replace from top

Select this option to have search and replace options automatically start from the beginning of the file.

Replace tabs with space

Select this option to insert spaces when the tab key is used. This also replaces existing tabs with spaces when a file is opened.

Show line numbers

Select this option to show line numbers.

Show replaced count

Select this option to show the number of strings that were replaced after the *Replace all* function has been used.

Use virtual space

Allows the cursor to move into space with no text.

Pad with tabs

Select this option to use tabs to fill in large empty spaces in virtual space. (Please refer to *Use virtual space* above.)

Remove ASCII 0's

Select this option to remove ASCII 0's from the file. If this option is disabled, ASCII 0's are replaced with ASCII 128.

If you transmit files with 7 data bits, ASCII 128 becomes ASCII 0.

Wrap Searches

Select this option to have searches continue from the top of the file if no match is found before the end of the file.

Always UPPER CASE

Select this option to force UPPER CASE (all CAPS).

Remember math values

Select this option to remember the previous values used in the Simple Math Functions.

Highlight current line

Select this option to highlight the currently selected line in the editor.

Show Whitespace and TAB

Select this option to show whitespace and tabulators in the editor.

Block Mode

Drag-and-drop text editing

Select this option to enable dragging of selected text.

Copy without selection

Select this option to copy the line at the cursor, without marking it as a selection.

Don't move cursor after paste

Select this option if you want the cursor to stay at the start of the text you have just pasted, instead of jumping to the end.

Mark to end of line

If a whole line is selected, the indication continues across virtual space to the side of the window.

Font settings

Preview field

This field shows an example of the selected font. Click the *Select font* icon  to change the font used in the editor window.

7.1.2. NC-Assistant

The *NC-Assistant* section allows you to configure the general behaviour of the NC Assistant.

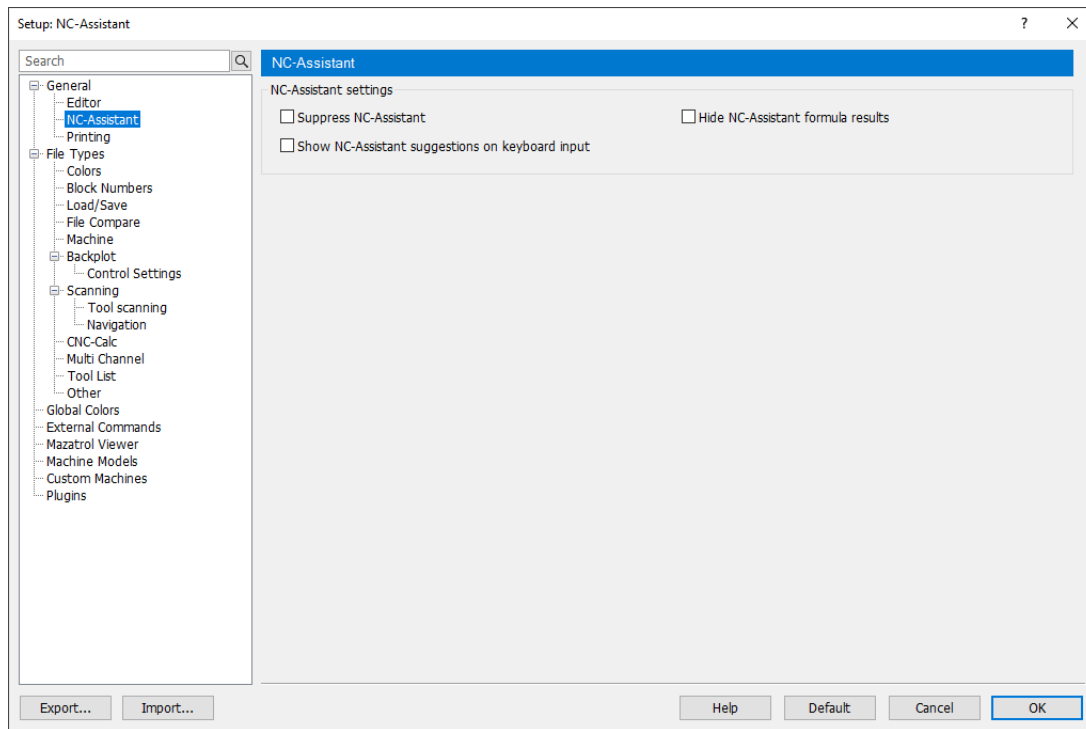

NC-Assistant settings.

NC-Assistant settings

Suppress NC-Assistant

Select this option to hide the NC-Assistant sidebar including macros. This option also disables the show/hide options under the [NC Assistant](#) tab

Show NC-Assistant suggestions on keyboard input

Select this option to enable NC-Assistant suggestions. A dropdown with NC-Assistant macro suggestions will appear as you type in the Editor.

Hide NC-Assistant formula results

Select this option if the result of NC-Assistant macro formulas should be hidden.

7.1.3. Printing

The *Printing* section allows you to configure the size of paper, fonts, headers/footers, multi-column printing, etc.

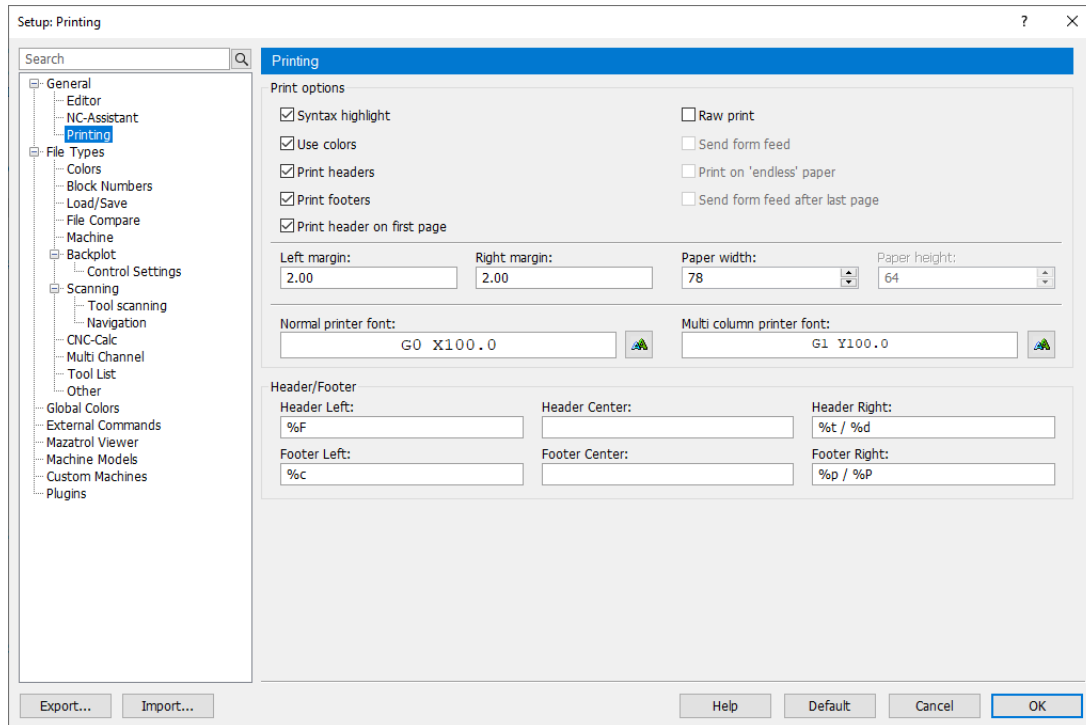

Printer setup.

Print options

Syntax highlight

Select this option to apply syntax highlighting to the printed text. Use Bold and Italic to highlight NC commands and comments.

Use colors

Select this option to enable color printouts. This requires a color printer.

Print headers

Select this option to print headers on every page.

Print footers

Select this option to print footers on every page.

Print header on first page

Select this option to print a header on the first page.

Raw print

Select this option to produce simple text output to the printer.

This is useful when printing large programs to matrix printers. When raw print is selected, the options *Syntax highlight*, *Use colors* and *Print header on first page* will be disabled.

The options *Send form feed*, *Print on endless paper*, *Send form feed after last page* and *Paper height* will be enabled to setup the raw print.

Send form feed

When this option is enabled, a form feed character (FF) will be sent after reaching the *Paper height* counter, and the next line will be printed on the next page. No form feed character is needed after the last page, so the option *Send form feed after last page* will be disabled.

Print on "endless" paper

Select this option to print on endless paper. When selected, no header and/or footer is printed.

Send form feed after last page

When this option is enabled, a form feed character will be sent at the end of a raw print on continuous paper to indicate the last printed page.

Left margin / Right margin

Specify the size of the margins in centimeters. If the margins are in inches add "in" such as '1in'.

Paper width / Paper height

Specify the size of the paper in width and height of the paper in characters.

If for example in multi-column printing the font size is set to 11 points and the *Paper Width* is set to 35 (characters/line), a CNC program of 140 NC blocks will be printed legibly in two columns on an A4 page.

Normal printer font

Shows a preview of the font used for normal printing.

Click the icon  to select the font size and type for the printout.



Multi column printer font

Shows a preview of the font used for Multi column printing.

Click the icon  to select the font used when printing in 2 or more columns.

Header/Footer

Header/Footer (Left, Center, Right)

Use these fields to specify the contents of the header and footer. The following options are available:

- %p : Page number
- %P : Page count
- %f : File name
- %F : File name with path
- %t : Time
- %d : Date
- %c : Company name
- %U : Windows user name

7.2. File Types

The *File Types* section allows you to manage File Types such as creating new ones, renaming, deleting and changing their order.

A File Type can be thought of as a configuration profile for CIMCO Edit. It defines a set of rules and settings that tell the editor how to behave when you are working with a specific type of file.

It includes settings for visual aspects, like how program lines are color coded, to functional behaviors, such as block numbering, associated file extensions, load/save directories, file comparison, and recognizing machine-specific NC codes. It also defines the default control and machine to use when running a simulating and much more.

When you open a file, you can switch the editor to the appropriate File Type from the [File Type](#) menu under the *Editor* tab.

Please note that selecting a File Type means that the settings in the subsections, such as Colors, Block Numbers, Load/Save, and others, will be specific to that File Type. Look for the current File Type in the dialog header to see which one you are configuring.

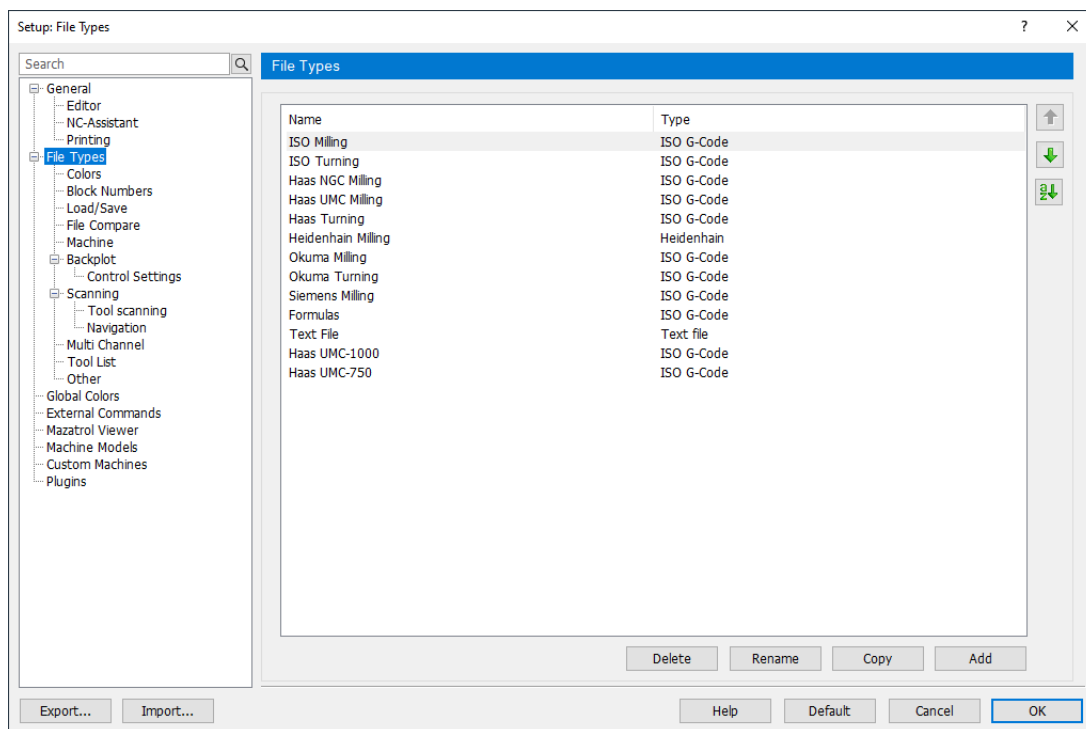



Overview of File Types.

File types



File Types

This field displays the list of file types.

Use the Up/Down arrows   to move the selected file type up or down in the list. You can also use the sort

button to alphabetically sort all file types.

Delete

Click this button to delete the selected file type. You will be prompted to confirm the delete operation.

Rename

Click this button to rename the selected file type.

Copy

Click this button to copy the selected file type.

Add

Click this button to add a new file type.

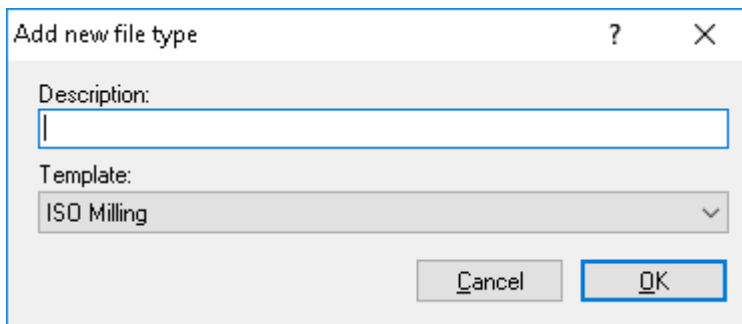

The screenshot shows a dialog box titled "Add new file type" with a question mark icon and a close button (X) in the top right corner. The dialog contains two main input areas: a "Description:" label followed by a text input field, and a "Template:" label followed by a dropdown menu currently displaying "ISO Milling". At the bottom right of the dialog, there are two buttons: "Cancel" and "OK".

Add file type.

Enter the name of the file type, select one of the predefined templates to base the new file type on and click *OK*.

7.2.1. Colors

The *Colors* section allows you to configure color settings for the selected file type.

This section can be accessed directly from the [File Type](#) menu under the *Editor* tab.

The settings in this section only apply to the selected *File Type*. If you wish to configure colors for a different File Type, go to the [File Type](#) section, change the type, and then revisit this section to continue. You can see the current File Type at the top of the dialog.

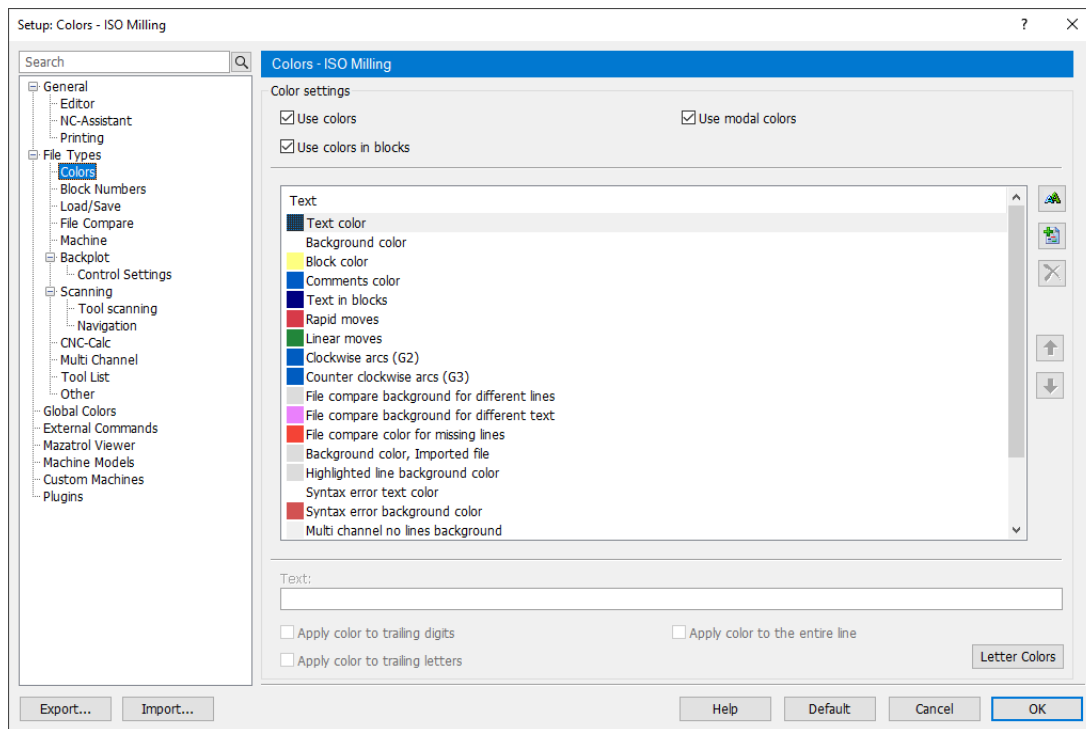

Color setup.

Color Settings

Use colors (Syntax Highlighting)

Select this option to use color highlighting in the editing window.

Use colors in blocks

Select this option to use color highlighting for the text inside a selected block. When this is unchecked, the default color for *Text in blocks* is used.

Use modal colors

Select this option to use 'modal' colors. Blocks containing rapid moves, linear moves, and arcs will be assigned different colors.

If all three options above are unchecked, all text, including comments, will use the color defined in *Text color*.



List of colors

This list shows all the colors defined in CIMCO Edit.

Change a color by double-clicking its name in the list. You can also select a color and click the  button on the right side of the list.

Colors higher in the list have priority. If two colors are listed for the same text, the color that is listed first will be used. Use the arrow buttons to move the selected color in the list.

Colors in the list include:

- **Text color**
The color used for text, when *Use colors* is not checked.
- **Background color**
The background color used for editor windows.
- **Block color**
The background color within a selection.
- **Comments color**
The color used for comments, as defined by the Comment start and Comment end, or Block Skip character on the Machine template configuration tab.
- **Text in blocks**
The color used in one or more selected program blocks when the field *Use color in blocks* is not checked.
- **Rapid moves**
The color used for rapid moves.
- **Linear moves**
The color used for linear moves.
- **Clockwise arcs (G2)**
The color used for clockwise arcs.
- **Counter clockwise arcs (G3)****
The color used for counter clockwise arcs.
- **File compare background for different lines**
The color used for the background for different lines.
- **File compare background for different text**
The color used for the background for different text.
- **File compare color for missing lines**
The color used for the background for missing lines.
- **Background color, Imported file**
- **Highlighted line background color**
The background color of the line where the cursor is located.
- **Syntax error text color**
The text color of syntax errors.
- **Syntax error background color**
The background color of syntax errors.
- **Multi channel no lines background**

The color used in sections with no lines.

- **Multi channel sync marker**

The background color used for lines with sync markers.

- **Multi channel sync error**

The background color used for lines with sync errors.

- **File compare difference wave**



Select color

Select a new color. To select a new color, highlight a color in the list and click on this button (you can also double-click the color in the list).



Add new color

Click this button to add a new color. The field *Text*, at the bottom of the dialog will become active.

1. Enter the character or string of text that should have the new color
2. Select the options below the field that should apply to the color



Remove selected color

Click this button to remove the selected color.

Only user defined colors can be deleted.



Up/Down arrows

Use these buttons to move the selected color up or down the list. Colors higher in the list have priority.



Text

Use this field to specify a character or string of text that will be highlighted using the selected color.



Apply color to trailing digits

Select this option to apply the color to all digits following the matched character or string in the *Text* field.



Apply color to trailing letters

Select this option to apply the color to all letters following the matched character or string in the *Text* field.

Apply color to the entire line

Select this option to apply the color to the entire line.

Letter Colors

Click this button to create and insert a different color for each letter (A-Z).

By default, these colors will match the color scheme in CIMCO Edit V4.

7.2.2. Block Numbers

The *Block Numbers* section allows you to configure line numbering for NC programs of the selected file type.

Block numbers serve as essential markers and are positioned at the start of each NC block. An NC program is primarily composed of these NC blocks, which sequentially outline the toolpaths necessary for machining a part.

CIMCO Edit helps ensure the integrity of these numbers during edits such as when adding new blocks. It also offers [Renumbering](#) features to restore proper line numbering after extensive changes.

The settings in this section only apply to the selected *File Type*. If you wish to configure block numbers for a different File Type, go to the [File Type](#) section, change the type, and then revisit this section to continue. You can see the current File Type at the top of the dialog.

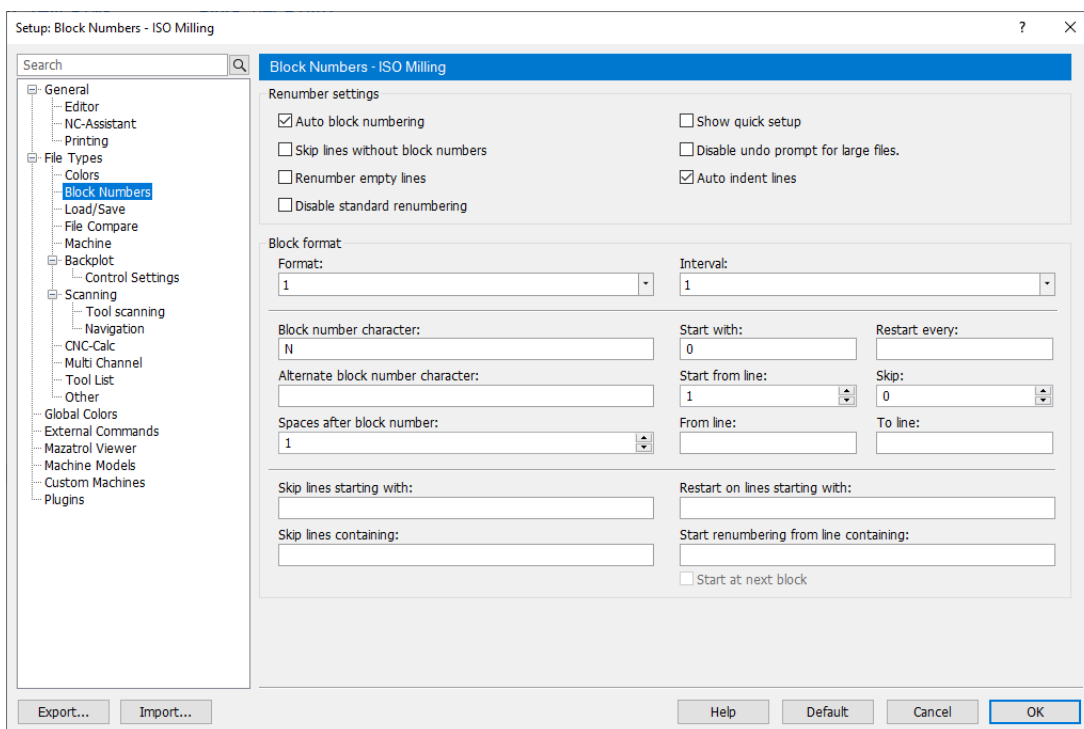

Block number configuration dialog.

Renumber Settings

Auto block numbering

Select this option to insert line numbers automatically based on the *Block format* settings in this dialog.

Upon inserting a new line, it will sequentially follow the number from the previous line, increasing by the chosen *Interval*.

If you add a new line in between other lines, its number will be halfway between the numbers of the line before it and the line after it.

Skip lines without block numbers

Select this option to skip lines without a block number when renumbering. The block number sequence is continued on the next line with a block number.

Renumber empty lines

Select this option to renumber empty lines such as a single empty line or several consecutive empty lines.

Disable standard renumbering

Select this option to disable the standard renumbering functionality for this file type. When using the *Renumbering* option under the *_NC Functions* tab, the [Advanced Renumbering](#) dialog will be shown instead.

Show quick setup

Select this option to show the following 'quick setup' dialog when using the [Renumbering](#) option under the *NC Functions* tab. This allows for swift configuration of the renumbering process.

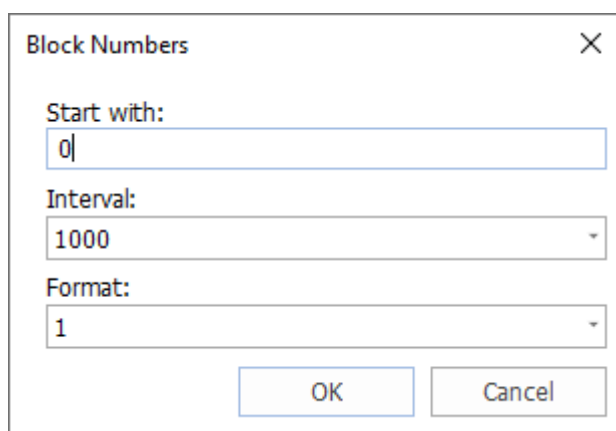

The image shows a dialog box titled "Block Numbers" with a close button (X) in the top right corner. It contains three input fields: "Start with:" with the value "0", "Interval:" with a dropdown menu showing "1000", and "Format:" with a dropdown menu showing "1". At the bottom are "OK" and "Cancel" buttons.

Quick setup dialog

Disable undo prompt for large files

When attempting to renumber large files, a prompt will appear requesting to continue the operation which cannot then be undone. By selecting this option, the operation will be performed without showing the prompt.

Auto indent lines

Select this option to indent new lines. The indentation will be set at the same level as the line above.

Block format

Format

This field provides a list of available block number formats. Select a format from the dropdown list. For example, if you need block numbers with four digits (like 0001 up to 9999), you would pick the 0001 format.

Interval

Use this dropdown to select the interval by which the block number must increase for each block. Preset intervals are 1, 2, 5, 10, 20, 100, 1000 and Auto.

If you select one of the Auto options, the number selected is the *maximum block number*, and the interval will be selected to distribute the block numbers as evenly as possible, within this maximum block number.

For example, selecting *Auto 1000* for a CNC program with 482 NC blocks will distribute the numbers between 0 and 964 (which is the highest multiple of 482 that is less than 1000).

Block number character

Use this field to enter a character or string that will be inserted before the line number. For ISO type machines, this is normally the letter 'N'.

Start with

Use this field to specify the starting value of the block numbering.

Restart every

Use this field to specify when the line number must restart. This number is equal to the maximum line number. For example, to use line numbers from 0-9999, specify 9999 in this field. If no value is specified, the line number will increment until it reaches 100000000, before it restarts.

Alternate block number character

Use this field to specify an alternate block number character. For example, if the control uses both 'N' and ':' for block numbers, specify ':' in this field.

123 Start from line

Use this field to specify the first line in the program that will be given a line number.

123 Skip

Use this field to specify if block numbers should skip lines. For example, if you specify 2 in this field, only every 3rd line will be numbered.

123 Spaces after block number

Use this field to specify the number of spaces to insert after the block number. To insert block numbers with a specific column width, specify a negative value.

123 From line

Use this field to specify the number of lines that should be skipped before the renumbering begins.

123 To line

Use this field to specify the maximum number of lines that should be renumbered.

Positive number

If a positive number is entered, it specifies the last line to be renumbered, counted from the beginning of the program.

For example, if your CNC program starts with 4 comment lines and a program start line (with program start trigger and number, but without 'N'), only the first 10 NC blocks will be renumbered if you specify 15 in this field.

Negative number

If a negative value (-N) is specified, the last N lines (counted from the end of the program) will not be renumbered.

For example, if you specify the value -2, and the last line of your CNC program (line containing the program end code M30) is followed by another line containing a special character (e.g. %), then only the last line is not renumbered.

123 Skip lines starting with

Defines that lines starting with a particular string and/or characters should be omitted, i.e. '%', 'O', '(', etc. Multiple strings can be specified using a comma ',' as separator. If you wish to omit lines beginning with a comma ',', specify ',,'.

123 Restart on lines starting with

Use this field to specify when the block numbers should be restarted. For example, to renumber several programs in the same file, specify 'O' in this field, then the block numbers will be reset every time an O-Number is encountered.

123 Skip lines containing

Use this field to specify that lines containing a character or string should be omitted. Multiple strings can be specified using a comma ',' as separator.

123 Start renumbering from line containing

Use this field to specify a renumbering start trigger. If you specify a renumbering start trigger, renumbering will start from the first block containing the specified string. To start from the first block after the block containing the string, check the Start at next block option below.

123 Start at next block

Select this option to start renumbering from the block after the line containing the renumbering start trigger.

7.2.3. Load/Save

The *Load/Save* section allows you to associate file extensions, set default directories, auto save and more for the selected file type.

The settings in this section only apply to the selected *File Type*. If you wish to configure a different File Type, go to the [File Type](#) section, change the type, and then revisit this section to continue. You can see the current File Type at the top of the dialog.

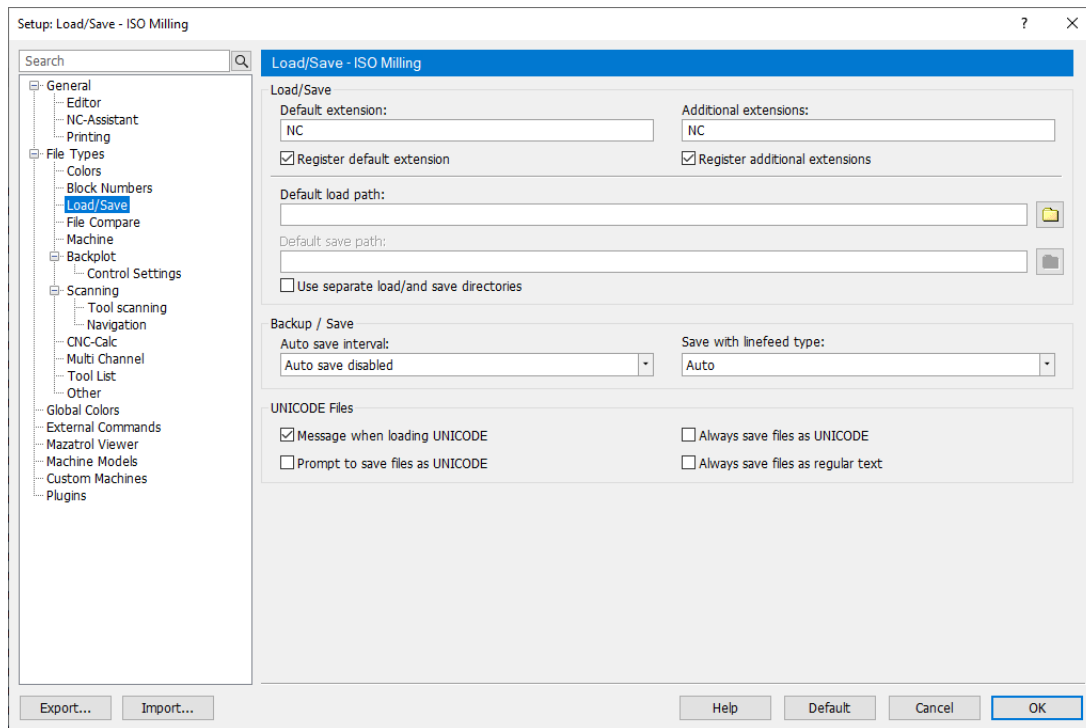

Load/Save dialog.

Load/Save

Default extension

Specify a default extension to use for the selected file type. This extension will be appended to any new files that are saved, unless an extension is specified in the *Save As* window.

Register default extension

Select this option to register the default extension(s) in Windows®. When an extension is registered in Windows®, clicking on a file with the specified extension in the Windows® Explorer will automatically open the file in CIMCO Edit.

Additional extensions

Define additional file extensions associated with your machine type. Extensions determine the type(s) of file(s) you wish to open (only files with the extension(s) defined here will be displayed in an Open file window). You
CIMCO Edit 2026 User Guide

can define more than one extension using a comma ',' as separator.

For example, to associate the extensions .ISO and .NC, specify ISO, NC.

Register additional extensions

Select this option to register the specified Additional extension(s) in Windows®. When an extension is registered in Windows®, clicking on a file with the specified extension in the Windows® Explorer will automatically open the file in the editor.

Default load path

This function specifies the default load path, which is where the file Open dialog will first point to. If no path is defined, the last directory you loaded a file from will be used. Click on the folder button  to browse for an adequate load path.

Default save path

This function specifies the default save path, which is where the file Save dialog will first point to, when you wish to save a new file of the selected type or when you use the file Save as menu. If no path is defined, the last directory you saved a file in will be used. Click on the folder button  to browse for an adequate save path.

Use separate load/and save directories

When this field is checked, the editor will remember the last load and save position independently.

Backup / Save

Auto save interval

Use this dropdown to select the length of the interval between auto saves. Auto saves overwrite the original file.

Save with linefeed type

Use this field to specify the linefeed type used when saving files.

- **Auto:** Do not change linefeed type. When saving new files, the DOS/Windows linefeed type is used.
- **DOS/Windows:** CR LF (ASCII 13 10)
- **Unix:** LF (ASCII 10)
- **Mac:** CR (ASCII 13)

UNICODE Files

Message when loading UNICODE

Displays a message when a UNICODE file is loaded.

Prompt to save files as UNICODE

Check this field if the file should be saved as UNICODE.

Always save files as UNICODE

Check this field if files should always be saved as UNICODE.

Always save files as regular text

Check this field if files should never be saved as UNICODE.

7.2.4. File Compare

The *File Compare* section allows you to configure the behaviour of the [File Compare](#) option.

The settings in this section only apply to the selected *File Type*. If you wish to configure a different *File Type*, go to the [File Type](#) section, change the type, and then revisit this section to continue. You can see the current *File Type* at the top of the dialog.

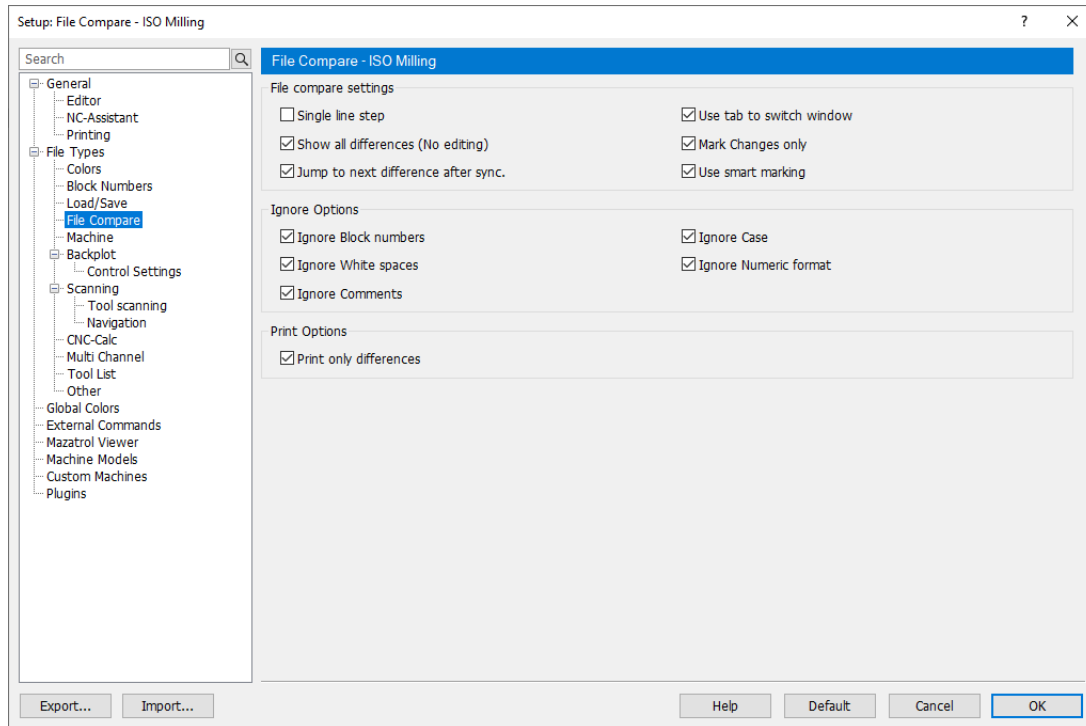

File compare dialog.

File Compare Settings

Single line step

Select this option to single step through multiple consecutive differences. Only the difference on the current line is highlighted.

Show all differences (No editing)

Select this option to show all lines with at least one difference. All the differences are highlighted at the same time.

Jump to next difference after sync.

Select this option to always jump to the next difference after you have synchronized two differences.

Use tab to switch window

Select this option if you want to use the tab key to switch between the two files being compared. You will not be able to insert tabs in any of the files when this option is enabled.

Mark Changes only

When you select this option, all the lines with at least one difference will be activated, but only the difference will be highlighted, not the entire line.

Use smart marking

When using this option, not only the different part of the command will be marked, but the complete command if it contains at least one difference.

Ignore Options

Ignore Block numbers

The values of block numbers will be ignored, as will the presence/absence of block numbers (i.e. the fact that there are block numbers in one file and not in the other will be ignored).

Ignore White spaces

White space characters will be ignored. White space characters are space (ASCII 32) and tab (ASCII 9).

Ignore Comments

Anything inside a comment will be ignored. For this to work, you must have specified the correct Comment start e.g. '(' and Comment end e.g. ')' characters for the [Machine](#) Template associated with the selected file type.

Ignore Case

If this option is checked, the letter case will be ignored, i.e. if one program contains lowercase and the other UPPERCASE characters for the same command.

Ignore Numeric format

Leading and trailing zeros will be ignored, as will optional '+' characters, i.e. 'X+14.10' matches 'X14.1', if this option is used.

Print Options

Print only differences

Select this option to only print the lines with differences between two files.

7.2.5. Machine

The *Machine* section allows you to configure machine specific program characters, NC codes, units and other machine related settings associated with the selected file type.

The settings in this section only apply to the selected *File Type*. If you wish to configure a different File Type, go to the [File Type](#) section, change the type, and then revisit this section to continue. You can see the current File Type at the top of the dialog.

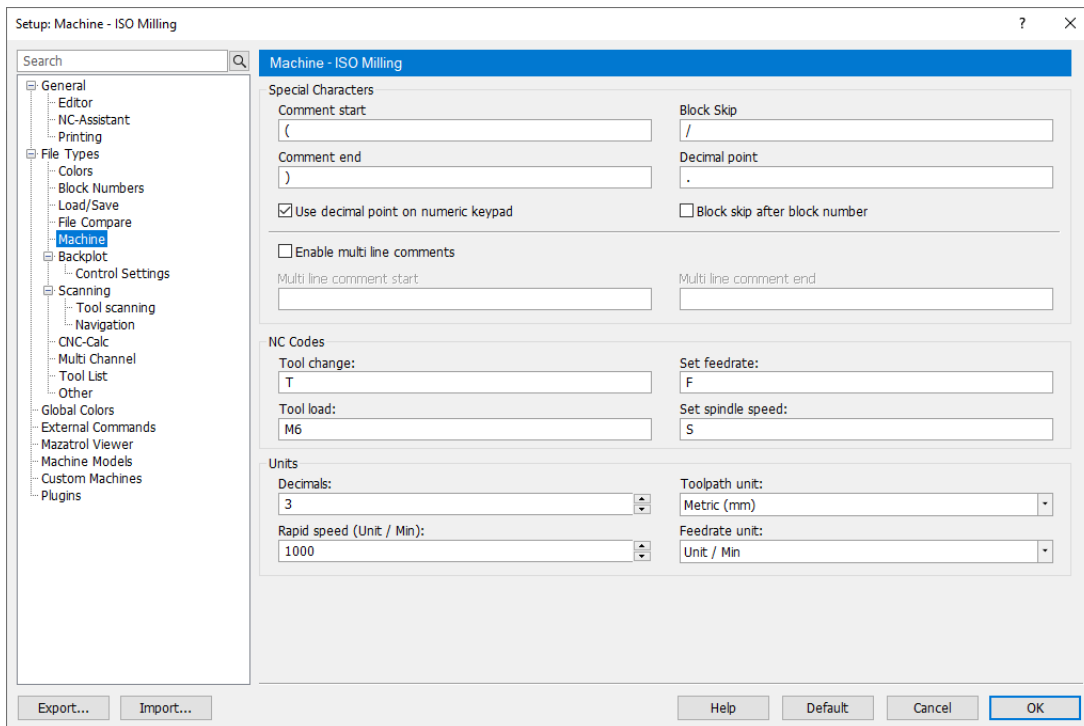

Machine type dialog.

Special Characters

Comment start

Use this field to enter the comment start character. For example (.

Comment end

Use this field to enter the comment end character. For example).

Block skip

Use this field to enter the block skip character. If you do not want a block skip character, just leave the field empty.

Decimal point

Use this field to enter the decimal separator (decimal point or comma).

Use decimal point on numeric keypad

Select this option if the decimal key on the numeric keypad should insert the decimal point specified above.

Block skip after block number

Select this option if a block skip should be inserted after the block number. If you leave this field unchecked, the block skip will be just before the block number.

You can specify another block skip character in the field *Block Skip*, if necessary.

Enable multi line comments

Select this option to enable coloring of multi-line comments.

Multi-line comment start

Use this field to specify the multi-line comment start string.

Multi-line comment end

Use this field to specify the multi-line comment end string.

NC Codes

Tool Change

Use this field to specify the tool change prefix.

For example, if the tool number is specified as T010101, specify T in this field.

Tool load

Use this field to specify the tool load command. If the tool load command is found on the same line as the tool change command, the tool is loaded immediately.

For example, N1230 T020202 M6.

Set feedrate

Use this field to specify the feedrate prefix.

For example, if the feedrate is specified as F1000, specify F in this field.

Set spindle speed

Use this field to specify the spindle speed prefix.

For example, if the spindle speed is specified as S1000, specify S in this field.

Units

These settings

Decimals

Use this field to specify the number of decimals shown in the backplot/simulation etc.

Rapid speed (mm / min)

Use this field to specify the default rapid feedrate.

Toopath unit

Select the toolpath measurement unit. This is used throughout CIMCO Edit including within the backplot/simulation etc.

Feedrate unit

Use this field to specify the default feedrate unit.

7.2.6. Backplot

The *Backplot* section allows you to configure the CNC control and machine configuration associated with the selected file type. This is also where you change the simulation version and export machine configurations.

The settings in this section only apply to the selected *File Type*. If you wish to configure a different File Type, go to the [File Type](#) section, change the type, and then revisit this section to continue. You can see the current File Type at the top of the dialog.

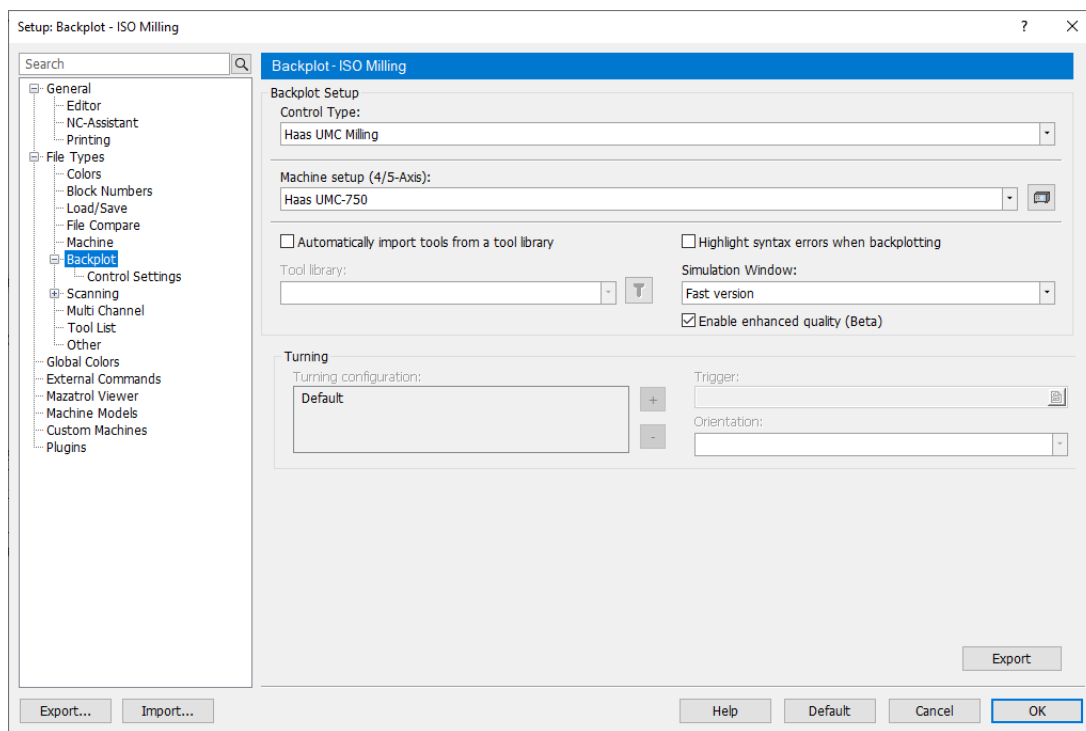

Backplot dialog.

Backplot Setup

Control Type

Use this dropdown to select the CNC control for the selected file type.

The CNC control includes the configuration of the controller-specific syntax and commands, which are used to interpret and simulate the CNC program accurately.

You can configure the selected control, or other controls, by first selecting it here and then navigating to the [Control Settings](#) section.

Machine Setup (4/5-Axis)

Use this dropdown to select a specific machine configuration for the selected file type.

Click on the machine icon next to the dropdown to edit the machine configuration. This will open the [Machine](#)

[Configuration Editor](#).

Only custom machines can be edited.

Automatically import tools from a tool library

Select this option to automatically load tools from a specified library when starting simulation.

Tool Library

Use this dropdown to select the library from which tools should be automatically loaded.

You can see the tools (Assemblies, Cutters, Holders) that have been loaded in the *list of current tools* in the [Tool Manager](#) (upper section).

Highlight syntax errors when backplotting

Select this option to highlight errors in the program code when running a simulation (Backplot/Machine Simulation).

Simulation Window

Use this dropdown to select the the simulation version. CIMCO Edit includes two simulation engines; the *Standard version* and the new *Fast version* which is now the default engine. See [Simulation](#) for more information.

Enable enhanced quality (Beta)

Use this checkbox to enable or disable the new enhancing algorithm in the simulation. This option is enabled by default and is only available for *Fast version* (see option above).

Turning

 **Turning Configuration**

List of orientation configurations. The default configuration will be selected unless a trigger is added to another configuration and this trigger finds the supplied text file.

Trigger

Use this field to set the trigger for the selected orientation configuration.

Orientation

Use this field to specify the orientation of the selected configuration.

Export

Export

Export the machine configuration as a .MacBundle file (Machine Bundle). The exported file can be used to import the machine configuration in CIMCO Edit on another PC.

When exporting, you will be asked to select the File Type. The control and machine configuration that corresponds to the selected File Type will be exported as part of the .MacBundle

Before exporting, please ensure the correct Control and Machine setup has been selected within the appropriate File Type.

7.2.6.1. Control Settings

The *Control Settings* section allows you to configure certain control specific parameters for the selected control and file type.

Changes to control parameters here are stored with the selected file type and does not overwrite the control configuration itself. This means you can have multiple file types that use the same control with different parameter settings.

Please see [Supported Controls](#) for more information about each control type.

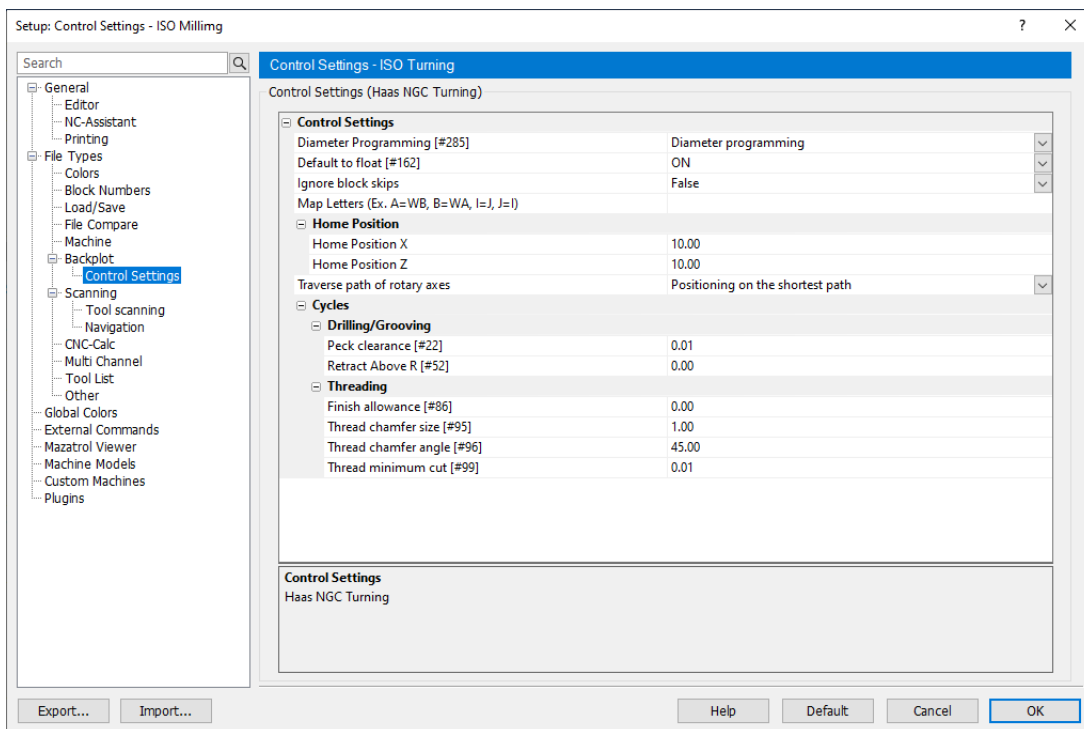

Control Settings dialog.

Control Settings



Control Settings

Use the fields available to configure the selected control. When selecting a parameter, a description can be found at the bottom of the dialog.

7.2.7. Scanning

The Scanning option in CIMCO Edit is used to load and save information about the configuration of workpiece, fixture, work offset, tools, holders, geometry, and more, associated with an NC program. This information, known as *Scanning Commands*, can either be inserted directly in the NC program or stored in a separate file.

When starting simulation, CIMCO Edit performs a 'scan' of the NC program or external file to locate and read the scanning commands. Following this, it is capable of loading, positioning, and setting up all the components within the simulation environment.

The Scanning feature is an invaluable tool for efficiency, allowing for the simultaneous loading of complete setups. Additionally, it facilitates the migration of setups from compatible CAD/CAM systems.

The settings in this section only apply to the selected *File Type*. If you wish to configure a different File Type, go to the [File Type](#) section, change the type, and then revisit this section to continue. You can see the current File Type at the top of the dialog.

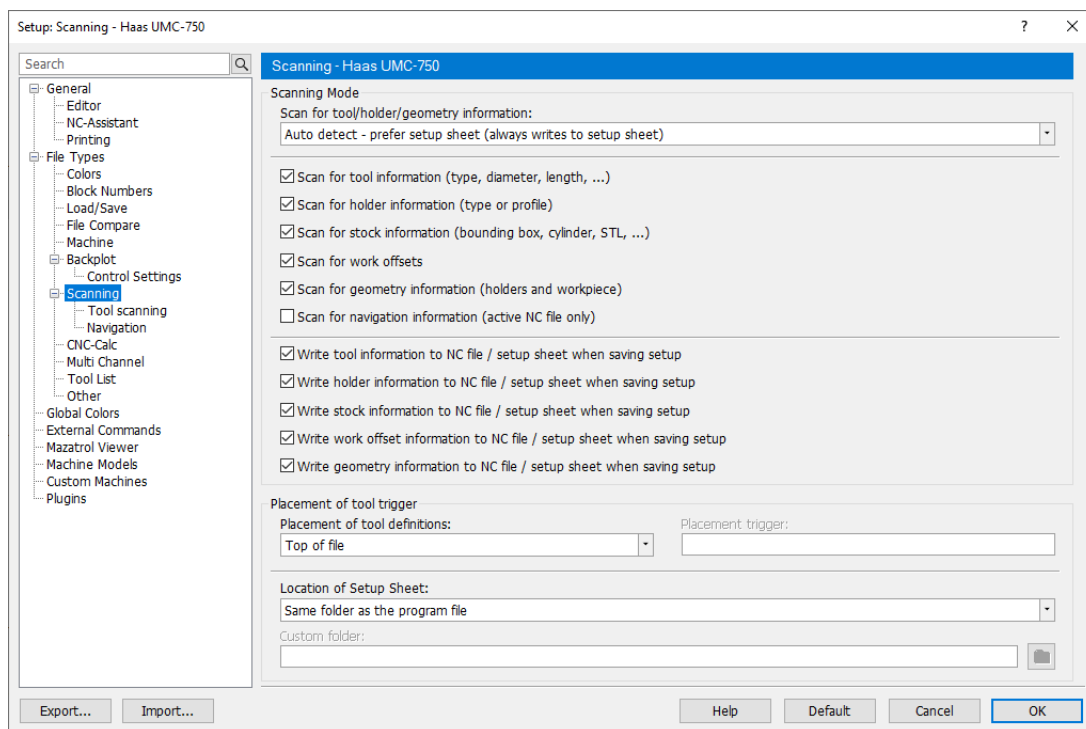

Scanning dialog.

The Scanning dialog consists of three sections: *Scanning Mode*, *Read/Write Settings* and *Placement of Tool Trigger*.

Scanning Mode

Scan for tool/holder/geometry information

Use this dropdown to select where CIMCO Edit should look for scanning commands about workpiece, fixture, tools, holders, etc.

- **Disabled:**

Select this to disable Scanning.

- **Auto detect - prefer NC program file (always writes to NC program file):**

Look for scanning commands in the NC program first. If nothing is found, look for a setup sheet (external .setup file). Always insert scanning commands in the NC program file.

- **Auto detect - prefer setup sheet (always writes to setup sheet):**

Look for scanning commands in the setup sheet (external .setup file) first. If nothing is found, look for scanning commands in the NC program file. Always save commands in the setup sheet.

- **Always use NC program file:**

Select this to always save scanning commands in the NC program file.

- **Always use setup sheet:**

Select this to always save scanning commands in the setup sheet (external .setup file).

Read Settings (Load)

Read settings specify what scanning commands to read from either the NC program or setup sheet. The scanning and loading of elements and geometry is an automatic process when starting simulation.

Scan for tool information (type, diameter, length, ...)

Select this option to scan for tool information (type, diameter, length, ...).

Scan for holder information (type or profile)

Select this option to scan for holder information (type or profile).

Scan for stock information (bounding box, cylinder, STL, ...)

Select this option to scan for stock information (bounding box, cylinder, STL, ...).

Scan for work offsets

Select this option to scan for work offsets.

Scan for geometry information (holders and workpiece)

Select this option to scan for geometry information (holders and workpiece).

Scan for navigation information (active NC file only)

Select this option to scan for navigation information (active NC file only).

You need to enable this option for [Navigation](#) to work.

Write Settings (Save)

Write settings specify what scanning commands should be saved to either the NC program or setup sheet. Follow these steps to save:

1. While simulation is running, right-click anywhere in the [Geometry Manager](#)
2. Select the option *Save Setup*

Write tool information to NC file / setup sheet when saving setup

Select this option to write tool information to NC file / setup sheet when saving setup.

Write holder information to NC file / setup sheet when saving setup

Select this option to write holder information to NC file / setup sheet when saving setup.

Write stock information to NC file / setup sheet when saving setup

Select this option to write stock information to NC file / setup sheet when saving setup.

Write work offset information to NC file / setup sheet when saving setup

Select this option to write work offset information to NC file / setup sheet when saving setup.

Write geometry information to NC file / setup sheet when saving setup

Select this option to write geometry information to NC file / setup sheet when saving setup.

Placement of Tool Trigger

Placement of tool definitions

Use this dropdown to select where scanning commands should be inserted when saving the setup to the NC program file.

- **Top of file:**

Insert all scanning commands at the top of the NC program file.

- **At tool change** Insert tool commands (definitions) before tool changes. All other scanning commands will be placed at the top of the NC program file.

- **Custom**

Insert all scanning commands at the specified *Placement trigger* (see option below).

If the selected placement fails, the scanning commands are placed at line 1.

Placement trigger

Use this field to specify a placement trigger which is a unique string of text (a keyword). Upon locating this string within the NC program, CIMCO Edit will insert all scanning commands immediately following it.

Location of Setup Sheet

Use this dropdown to select where the Setup Sheet should be located.

- **Same folder as the program file:**

Create Setup Sheet (.setup file) in the same folder as the program file.

- **Data folder:**

Create Setup Sheet (.setup file) in the \CIMCOEdit\Data\ folder.

- **Custom folder (specify below):**

Create Setup Sheet in a folder selected by the user (see *Custom folder* below).

Custom folder

Use this field to specify a folder path for the Setup Sheet. Use the folder icon next to this field to browse for a folder.

7.2.7.1. Scanning Commands

Scanning Commands are used for loading and defining elements such as workpiece, fixture, work offset, tools, holders, and more. These commands can be found within the NC program itself or within a separate Setup Sheet.

Below is a brief guide that outlines the general structure of some common Scanning Commands. Please note that this is not an exhaustive list of all the commands available.

For a practical understanding, we recommend conducting tests by saving the Scanning Commands to a copy of your NC program or to a Setup Sheet (.setup file). This hands-on approach will allow you to see the specific commands in action and understand their configurations.

The example below shows scanning commands in a Setup Sheet file.

```
TOOL 1 "LOLLIPOP MILL" HOLDER=H1 COMMENT="TOOL DESCRIPTION 1" A00 BL40 CPI=T8
D10 FL20.5 US=UM AD10 SD2 SL30 TL0
TOOL 2 "END MILL" HOLDER=H1 COMMENT="TOOL DESCRIPTION 2" A00 BL40 CD0 CR5
CPI=T8 EMCT=BEM D10 FL20.5 US=UM AD10 SD10 SL30 TL0
HOLDER BEGIN H1 "BT50" UM
69.85, 69.85, 3
100, 100, 12.5
100, 85, 4.33
85, 85, 6.34
85, 100, 4.33
100, 100, 7.3
HOLDER END
WORKPIECE ID1 "workpiece_1.stl" X0 Y0 Z0 A0 B0 C0 UM
WORKPIECE ID2 "workpiece_2.stl" X0 Y0 Z0 A0 B0 C0 UI RGB=127,127,0
FIXTURE ID1 "fixture_1.stl" X0 Y0 Z0 A0 B0 C0 UM
FIXTURE ID2 "fixture_2.stl" X0 Y0 Z0 A0 B0 C0 UM RGB=120,4,29
WCS ID0 X100 Y100 Z0
WCS ID1 X300 Y200 Z0
WCS ID2 X300 Y300 Z0
```

The following scanning command is used for loading and positioning an STL model for a fixture or workpiece.

```
<TYPE> ID<ID> "<FILENAME>" X<NUMBER> Y<NUMBER> Z<NUMBER> A<NUMBER> B<NUMBER>
C<NUMBER> <UNIT> <COLOR?>
```

Description of parameters

Param	Description
TYPE	Either of the two strings: FIXTURE or WORKPIECE
ID	Integer
FILENAME	Path to an ".stl" file
NUMBER	Integer, Float, X,Y,Z Coordinate or A,B,C Euler transformation
UNIT	Either of the two values: UM for Metric or UI for Imperial
COLOR	Optional parameter for color. RBG=<0-255>,<0-255,<0-255>. Defaults to 129,129,129 (gray)

Example of scanning command in either the NC program or the Setup Sheet.

```
WORKPIECE ID1 "workpiece_1.stl" X0 Y0 Z0 A0 B0 C0 UM
WORKPIECE ID2 "workpiece_2.stl" X0 Y0 Z0 A0 B0 C0 UI RGB=127,127,0
FIXTURE ID1 "fixture_1.stl" X0 Y0 Z0 A0 B0 C0 UM
FIXTURE ID2 "fixture_2.stl" X0 Y0 Z0 A0 B0 C0 UM RGB=120,4,29
```

The following scanning command is used for loading/defining a tool.

```
TOOL <TOOL NUMBER> "<TYPE>" HOLDER=<HOLDER ID> COMMENT="<COMMENT>" <UNIT?>
<DIMENSIONS>
```

Description of parameters

Param	Description
TOOL NUMBER	Integer with tool number
TYPE	String with tool type
HOLDER ID	Optional, Alphanumeric string [a-zA-Z0-9_-]
COMMENT	Optional, comment / description of tool
UNIT	Optional parameter with two possible values: UM for Metric and UI for Imperial
DIMENSIONS	List of tool dimensions

Please refer to the [Tool Scanning](#) section for further information about the tool scanning command and its associated dimension parameters.

The following scanning command is used for loading/defining a holder for milling.

```
HOLDER BEGIN <ID> "<COMMENT>" <UNIT> FILE="<FILENAME>"
<NUMBER>, <NUMBER>, <NUMBER> # Holder Segment: (Upper diameter, Lower
diameter, Length of the segment)
HOLDER END
```

Description of parameters

Param	Description
ID	Alphanumeric string [a-zA-Z0-9_-]
COMMENT	Optional, comment / description of holder. Must be encapsulated with double quotation marks
UNIT	Optional parameter with two possible values: UM for Metric or UI for Imperial
NUMBER	Integer, Float, Fraction
FILENAME	Optional. The path to an STL model to replace the holder. See Tool Manager for more information about Filename

Example of scanning command in either the NC program or the Setup Sheet.

```
HOLDER BEGIN H2 "B2C4-0011"
42.9514,1.524,45.9994
45.9994,6.0706,45.9994
45.9994,2.00406,39.0652
37.9984,4.0132,37.9984
```

```

39.06012,2.00406,45.9994
45.9994,3.1242,45.9994
45.9994,1.27,43.4594
22.225,3.175,15.875
15.875,31.75,15.875
15.875,1.4478,12.7
12.7,5.334,12.7
14.986,0.508,16.002
16.002,11.43,16.002
16.002,0.508,14.986
HOLDER END

```

The following scanning command is used for loading/defining the work offset.

```
WCS ID<INDEX> X<NUMBER> Y<NUMBER> Z<NUMBER> A<NUMBER> B<NUMBER> C<NUMBER>
```

Description of parameters

Param	Description
INDEX	Integer referring to the work offset index. (Currently we support 7 different work offsets (0-6))
NUMBER	X, Y, Z, A, B, C coordinate. Integer or Float

Example of scanning command in either the NC program or the Setup Sheet.

```
WCS ID1 X0.000 Y0.000 Z99.000 A0.000 B0.000 C0.000
```

7.2.7.2. Tool Scanning

The *Tool Scanning* section allows you to configure the format of the Scanning Command used for loading both milling and turning tools. This is the format CIMCO Edit will *scan* for in the NC program or Setup Sheet file when starting simulation and also the format it will use when saving a setup and Scanning Commands.

The Scanning Command for a tool contains several letter codes such as AO, BL, CPI, etc. These are referred to as *Keywords* and define different aspects of a tool such as Shaft Diameter (AD), Body Length (BL) or Cutter Point Index (CPI). If required, the naming of some of these keywords can be changed.

Please refer to the [Scanning](#) section for more information about Scanning Commands and how they are used in CIMCO Edit.

The dialog has two variations with one set of options for milling tools and another for turning tools. Which one is shown depends on what *Control Type* is selected for the current [File Type](#) and the *Control Type* is set in the [Backplot](#) section. However, any changes made in the Tool Scanning dialog will be associated (saved) with the selected [File Type](#).

The settings in this section only apply to the selected *File Type*. If you wish to configure a different File Type, go to the [File Type](#) section, change the type, and then revisit this section to continue. You can see the current File Type at the top of the dialog.

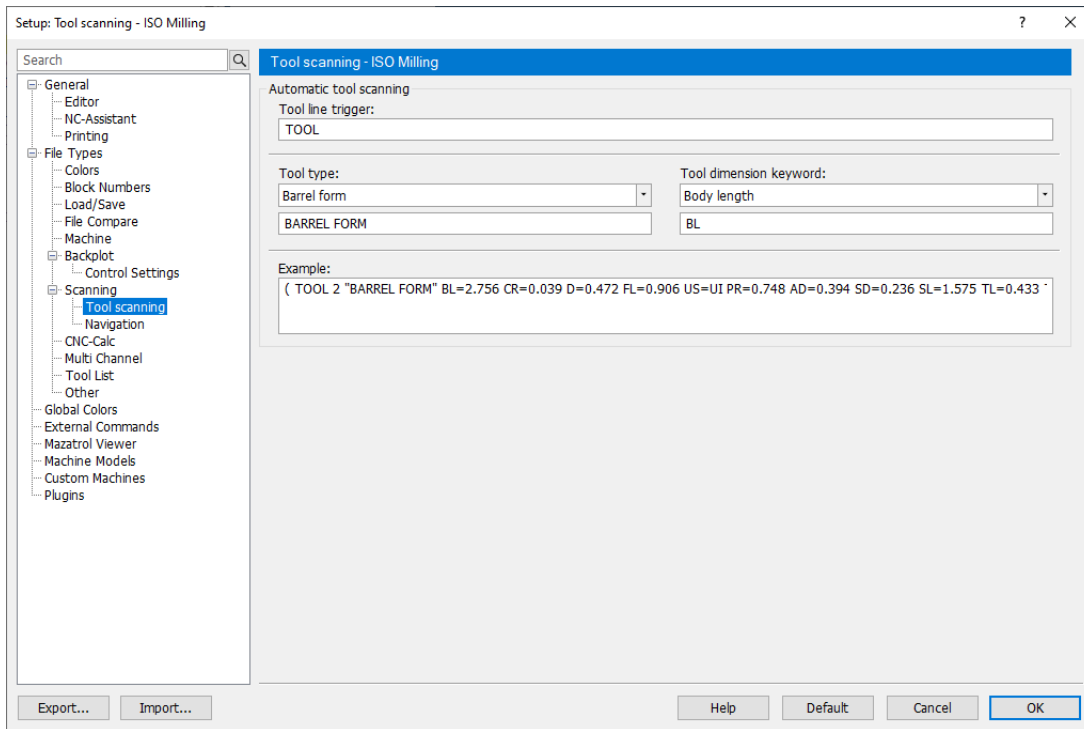

Tool Scanning dialog (Milling tool).

Automatic tool scanning (milling)

Tool line trigger

Use this field to enter the string that identifies a line as a tool.

Tool type

Use this dropdown to select a tool type and see/update its parameter name in the field below. The *Tool dimension keyword* dropdown will also update with the keywords available for the selected tool type.

Tool dimension keyword

Use this dropdown to select a tool dimension and see/update its keyword in the field below.

Example

This fields shows an example of the resulting Scanning Command.

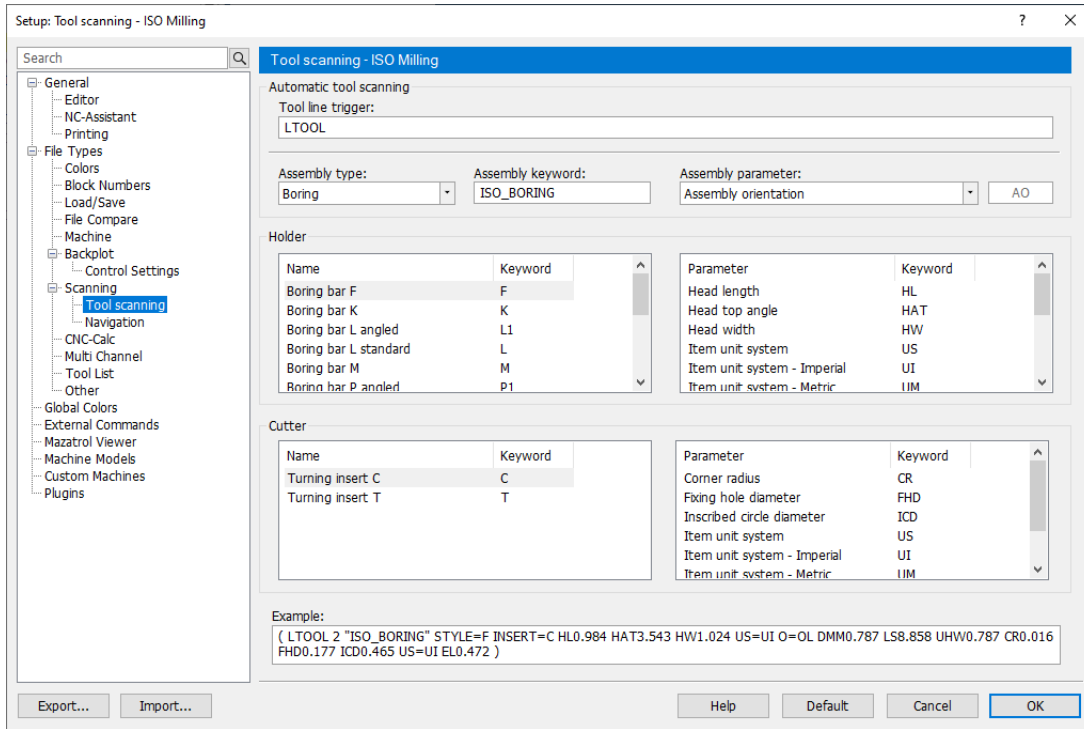

Tool Scanning dialog (Turning tool).

Automatic tool scanning (turning)

Tool line trigger

Use this field to enter the string that identifies a line as a tool.

Assembly type

Use this dropdown to select an Assembly type and see/update its keyword in the field *Assembly keyword*. All other fields and dropdowns will also update to show the parameters and keywords available for the selected Assembly type and its components.

Assembly keyword

Use this field to enter a keyword for the selected Assembly type.

Assembly parameter

Use this dropdown to see a list of parameters available for the selected Assembly type. The associated keyword is shown in the field on the right (cannot be changed).

Holder

Use these fields to select a holder and see its parameters and keywords. These cannot be changed.

 **Cutter**

Use these fields to select a cutter and see its parameters and keywords. These cannot be changed.

 **Example**

This fields shows an example of the resulting Scanning Command.

7.2.7.3. Navigation

The *Navigation* section allows you to configure the structure and what keywords to *scan* for and show in the Navigation tab.

During the simulation of an NC program, the Navigation tab offers a well-organized overview (a tree menu) of the program's contents. This feature facilitates quick and effortless pinpointing of corresponding positions in both the NC program and the Navigation tab.

Please see [Navigation tab](#) for information about how to use Navigation.

To activate Navigation, you must first enable the option 'Scan for navigation information' found within the [Scanning](#) section of the Editor Setup.

The settings in this section only apply to the selected *File Type*. If you wish to configure a different File Type, go to the [File Type](#) section, change the type, and then revisit this section to continue. You can see the current File Type at the top of the dialog.

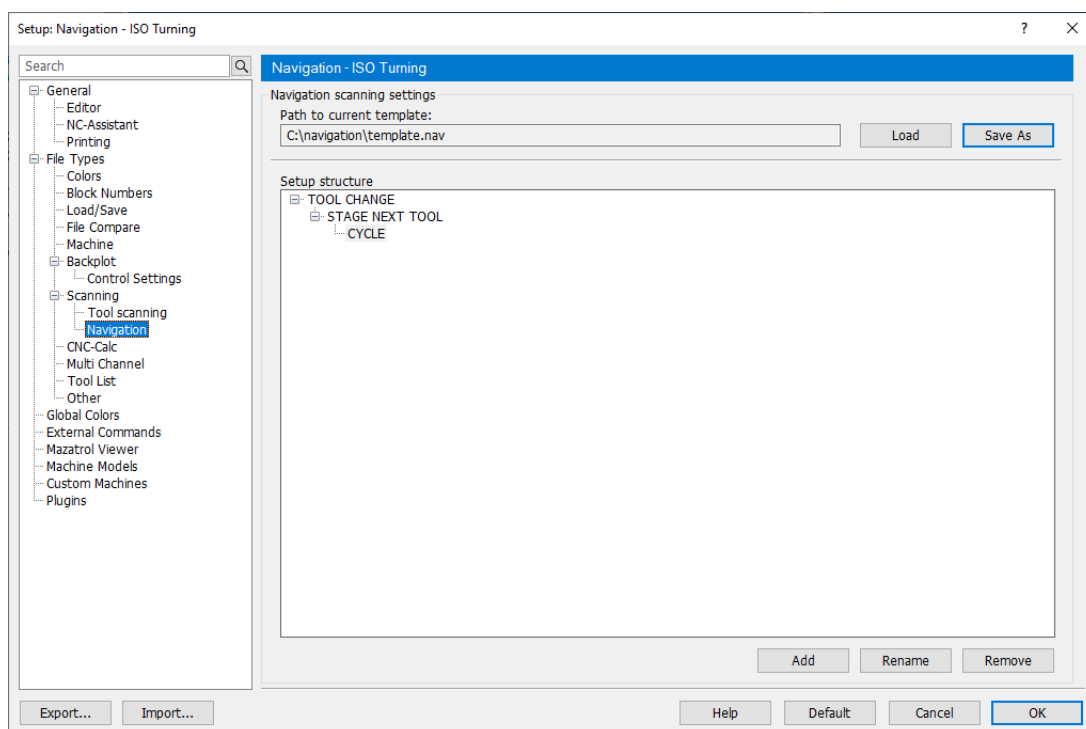

Navigation dialog.

Navigation scanning settings

 **Path to current template**

Shows the path to the file containing the current navigation template.

 **Load**

Locate and load a navigation template.

 **Save As**

Save the navigation tree structure.

 **Setup structure**

Shows the keywords that CIMCO Edit will scan for within the active NC program and how they should be structured within the [Navigation tab](#).

 **Add**

Click this button to add a keyword to the navigation tree, note that the structure only permits a single child node under each branch, with a depth limit of 8 levels. By selecting the 'Add' button, you will append a new child node directly below the currently deepest nested level.

 **Rename**

Click this button to rename the selected keyword. You can also double-click the keyword to rename.

For Navigation to work, you have to rename the levels to match the word(s) you want to 'scan' for in the NC program. You can only scan for words within comments in your NC program. You might have:

- TOOL CHANGE
 - OPERATION

Depending on the NC program, the resulting structure in the Navigation tab might look like:

- **TOOL CHANGE - T1 ENDMILL**
 - **OPERATION 1**
 - **OPERATION 2**
 - **OPERATION 3**
 - **OPERATION 4**
- **TOOL CHANGE - T2 BALL**
 - **OPERATION 5**

- **OPERATION 6**
- **OPERATION 7**
- **OPERATION 8**

It is important to note that you can only scan for words within comments in your NC program.

 **Remove**

Click this button to remove the selected keyword.

If no template path has been specified, you will be asked to save changes to the setup structure when closing the dialog.

7.2.8. Multi Channel

The *Multi Channel* section allows you to configure how CIMCO Edit should identify multi-channel specific program codes for the selected File Type. It also provides options for the visual layout of channels in the editor and printing.

The Multi Channel option enables you to simultaneously view an NC program for machines with two or more channels. Channels are displayed side-by-side in separate editor windows, and the feature also incorporates the synchronization provided by Wait codes.

Channel windows can be synchronized with wait codes and editing can be done in all windows. Wait codes that match are shown in yellow and missing wait codes are shown in purple.

The settings in this section only apply to the selected *File Type*. If you wish to configure a different File Type, go to the [File Type](#) section, change the type, and then revisit this section to continue. You can see the current File Type at the top of the dialog.

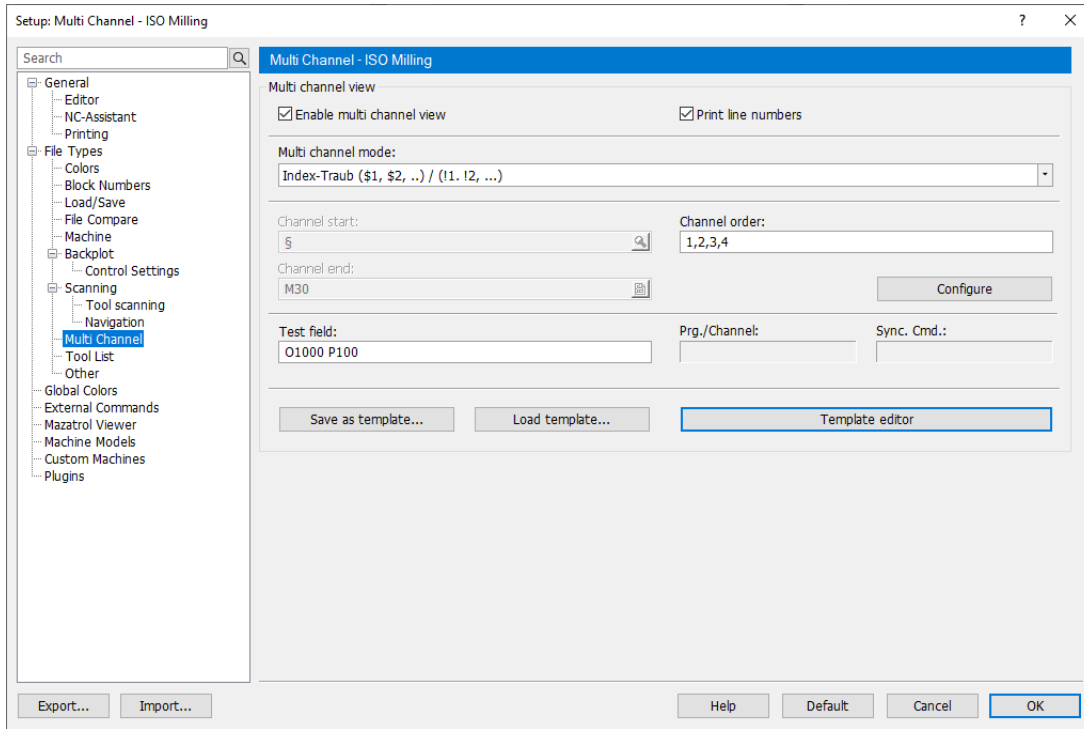

Multi Channel dialog.

Multi Channel View

Enable multi channel view

Check this field to enable Multi Channel view. If this is disabled, the options for multi-channel viewing in the [NC-Assistant](#) tab will also be disabled.

Print line numbers

Check this field to include line numbers when printing a program in multi-channel mode.

Multi channel mode

Use this dropdown list to specify how to read the multi channel commands. You can either select one of the predefined types, or the *User Defined* type to manually define the multi channel commands using the fields below.

Channel start

Use this field to specify the Channel start command when multiple channels are stored in the same program file.

For instance, if you specify O as the Channel start command, CIMCO Edit will look for an O number at the beginning of each channel's section in the file. You can define multiple Channel start commands separated by commas to accommodate different starting points for each channel. For example, if the first channel starts with G13 and the second channel starts with G14, you would specify G13,G14 as the Channel start commands

Channel end

Use this field to specify the Channel end command when multiple channels are stored in the same program file. Please refer to *Channel start* for more details.

For example, enter M30 if each channel ends with M30. You can also specify the end of channel information using an advanced trigger / Regular Expression.

Channel order

Use this field to specify the order in which the channel windows should be displayed. Default is 1,2,3,4. To reverse the channels use 4,3,2,1 and so forth.

Configure

Click this button to open the [Multi Channel Configuration](#) dialog where you can configure synchronisation commands to a set of defined channels.

Test field

Use this field to test different commands such as *Channel start/end* and Synchronisation commands.

Save as template

Click this button to save the current configuration as a reusable template.
A dialog will appear where you can enter a name for the new template or choose to overwrite an existing one.

Load template

Click this button to load a template.

Template editor

Click this button to open the Template Editor.

For details about the available options, refer to this document and the information under the [Multi Channel Configuration](#). The options in the Template Editor are identical to those described there.

7.2.8.1. Multi Channel Configuration

The *Multi Channel Configuration* dialog allows you to configure the commands used to synchronisation channels in an NC program.

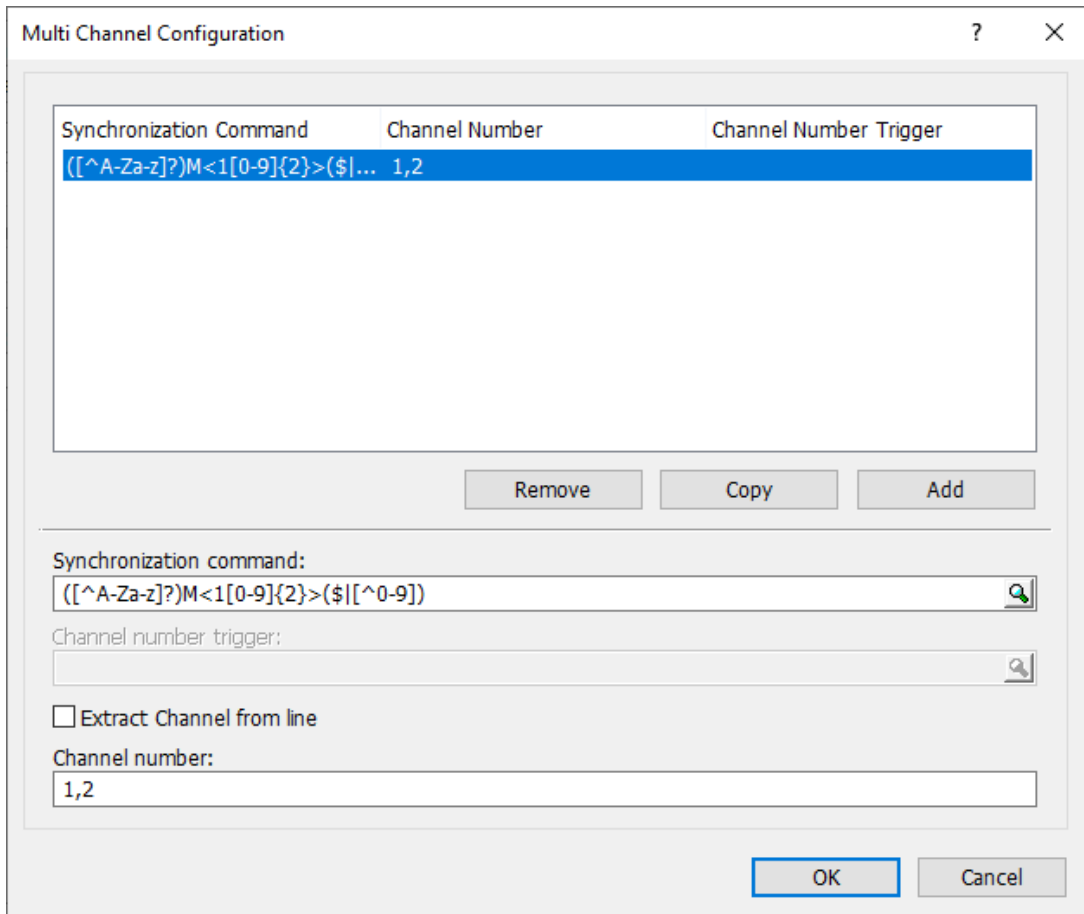

Multi Channel Configuration dialog.

Options

List of Synchronization Commands

This listbox displays all configured Synchronization Commands including their expression, Channel Number and Channel Number Trigger.

Add button:

Use the *Add* button below the listbox to add a new Synchronization Command which will simply add a blank entry in the list. Once you enter a an expression in the *Synchronization Command* field below this will show up in the list.

Copy and Delete buttons:

Use the *Copy* and *Delete* buttons below the field to copy or delete the selected Synchronization Command. Note that CIMCO Edit will not ask for confirmation before deleting a Synchronization Command.

Synchronization Command

Use this field to enter a string or [Regular Expression](#) that will identify a synchronization point/code in the NC program.

Basic Usage (String)

If synchronization points are indicated with !1, !2, etc., specify ! in this field. Make sure to select *String* from the dropdown button on the right side of the field.

Advanced Usage (Advanced)

If you need to specify the command using an advanced trigger (Regular Expression), you must add < > around the synchronization information to capture/extract it. Make sure to select *Advanced* from the dropdown button on the right side of the field.

Examples:

1. To synchronize on M300-M399, specify: M3<[0-9][0-9]>
2. To synchronize on all Pxxx, specify: P<[0-9]+>

Channel number trigger

Use this field to enter a string or [Regular Expression](#) (trigger) that will be used to identify channel numbers in the line from the *Synchronization Command* field above.

Extract channel from line

Select this option to enable the *Channel number trigger* field above. This allows you to extract the channels to synchronize from the line identified in the *Synchronization Command* field above.

Channel number

Use this field to enter the channel numbers to synch for the *Synchronization Command* field above.

Examples

Macodel

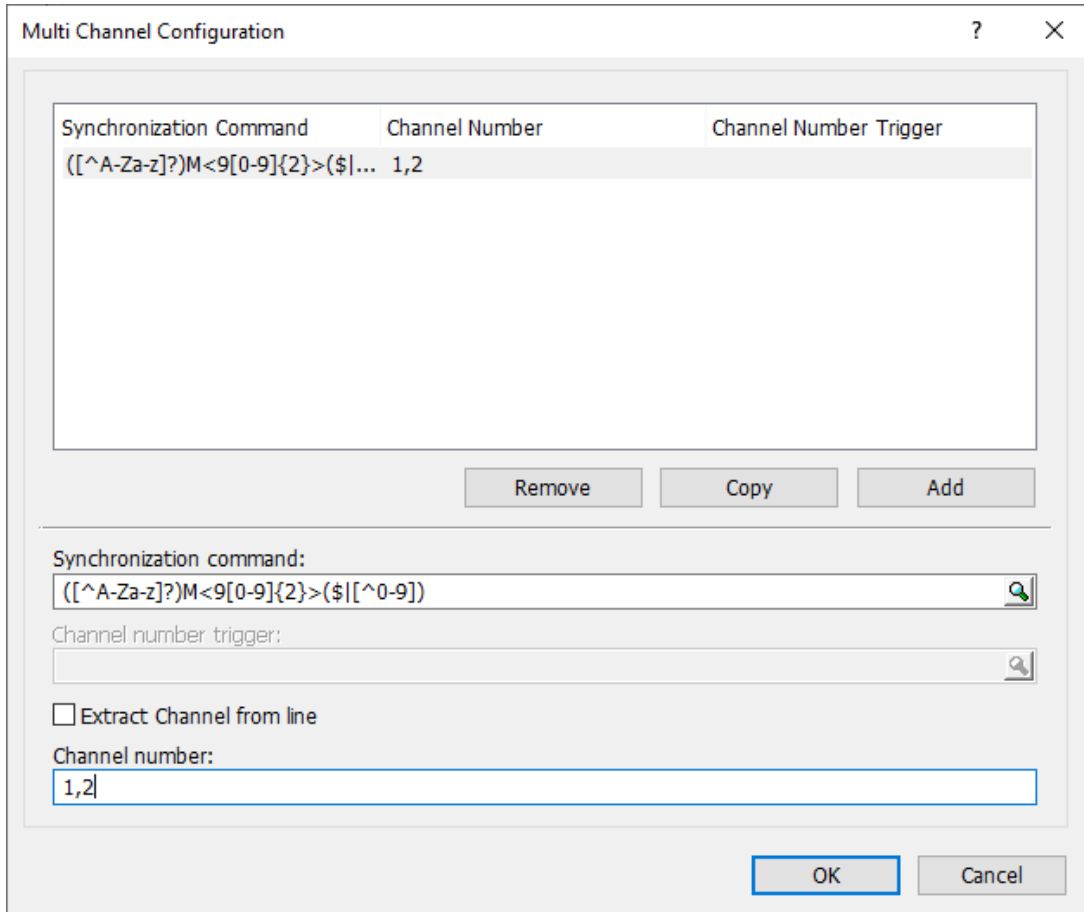

Macodel example.

Synchronization command:

`([A-Za-z]?)M<9[0-9]{2}>($|^[0-9])`

How the expression works:

Segment	Description
<code>([A-Za-z]?)</code>	Ignores cases where any letter precedes "M".
<code>(\$ ^[0-9])</code>	Ignores cases where there is any numbers after.
<code><9[0-9]{2}></code>	Capture 9 followed by exactly two numbers between 0 and 9.

Channel number: 1,2

DMG Mori

Similar to Macodel, but with M100 to M199.

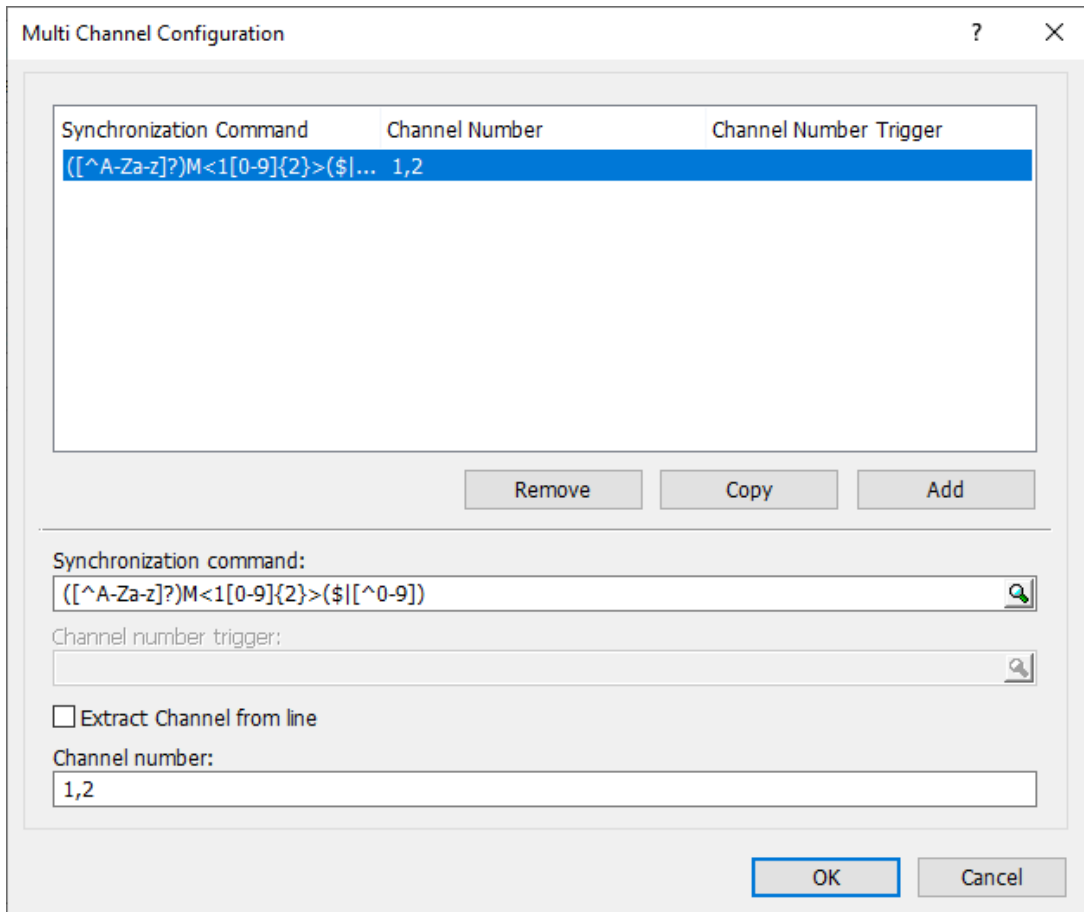

DMG Mori example.

Synchronization command:

`([A-Za-z]?)M<1[0-9]{2}>($|^[^0-9])`

Segment	Description
<code>([A-Za-z]?)</code>	Ignore cases where any letter precedes "M".
<code>(\$ ^[^0-9])</code>	Ignore cases where there is any numbers after.
<code><1[0-9]{2}></code>	Capture 1 followed by exactly two numbers between 0 and 9.

Channel number: 1,2

Star

Similar to Macodel and DMG Mori, but with M200 to M899.

Other M-Codes are not channel synchronization, they are for axis synchronization, these are not appropriate for multi-channel view, as these codes do not block program execution.

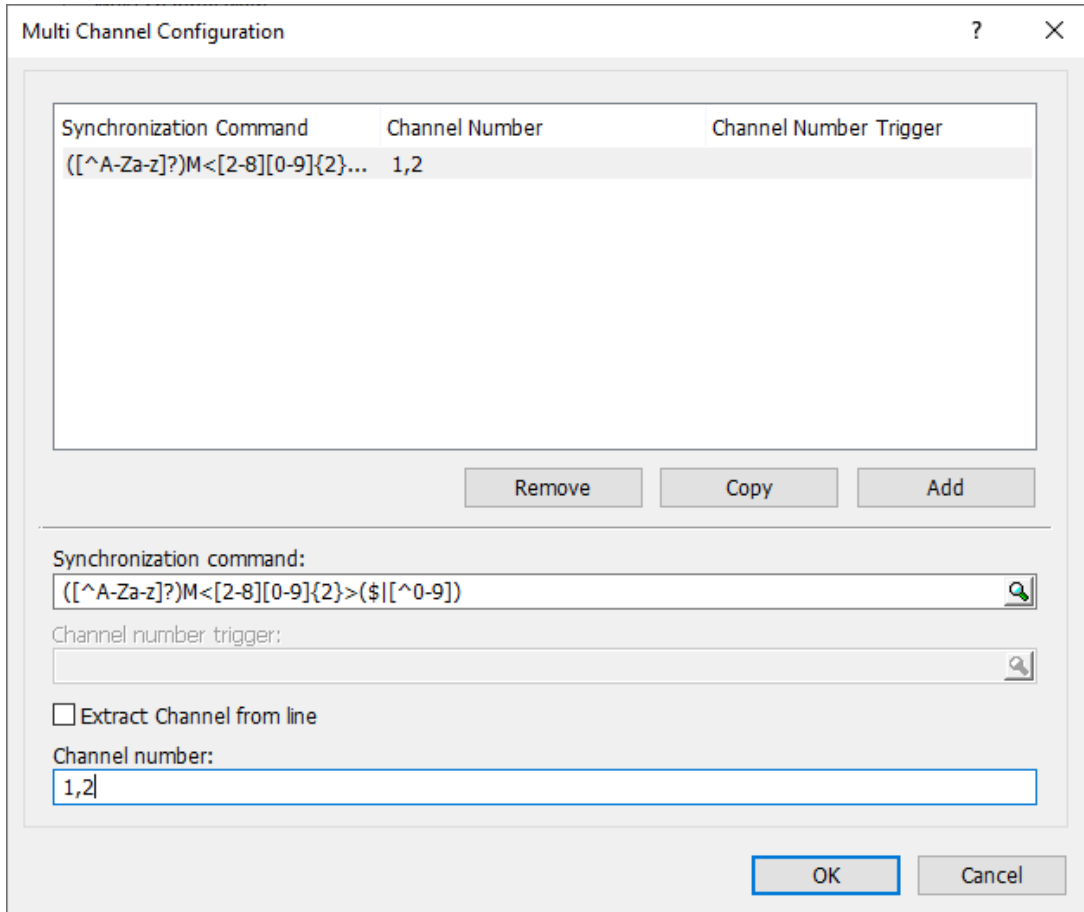

Star example.

Synchronization command:

`([A-Za-z]?)M<[2-8][0-9]{2}>($|[0-9])`

Segment	Description
<code>([A-Za-z]?)</code>	Ignore cases where any letter precedes "M".
<code>(\$ [0-9])</code>	Ignore cases where there is any numbers after.
<code><[2-8][0-9]{2}></code>	Capture number between 2 and 8 followed by exactly two numbers between 0 and 9.

Channel number: 1,2

7.2.9. Tool List

The *Tool List* section allows you to set up tool list triggers and configure the layout of tool lists.

The settings in this section only apply to the selected *File Type*. If you wish to configure a different *File Type*, go to the [File Type](#) section, change the type, and then revisit this section to continue. You can see the current *File Type* at the top of the dialog.

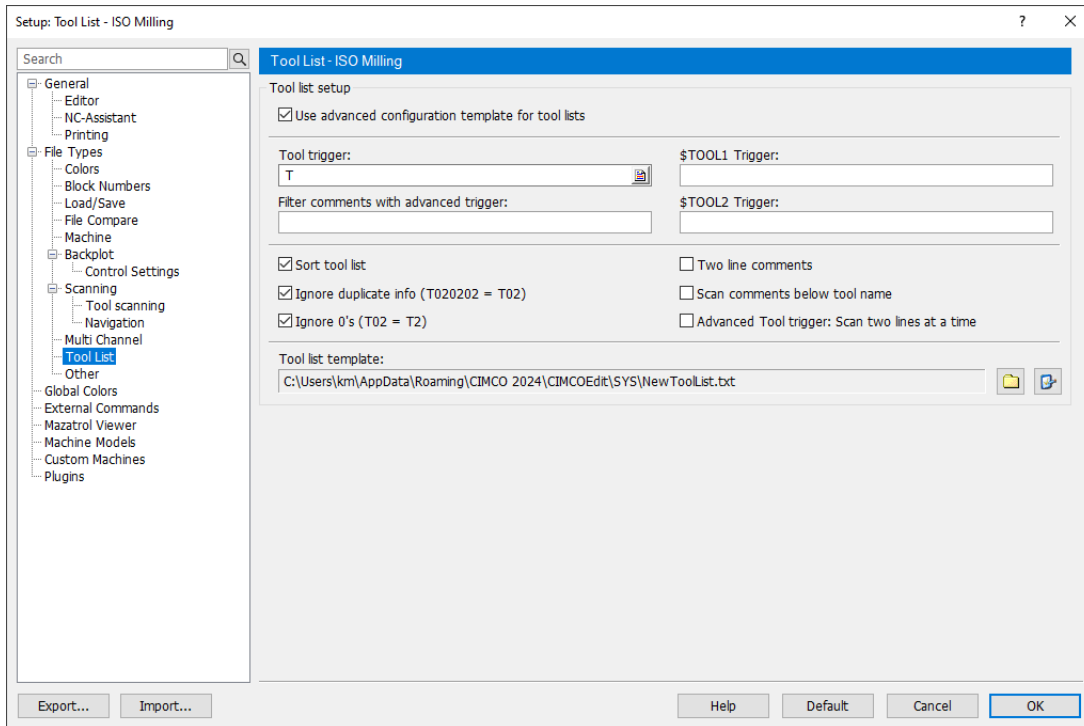

Tool List dialog.

Tool List Setup

Use advanced configuration template for tool lists

Check this field to use the advanced tool list generator that offers a wider range of customization options for tool lists, including both HTML and XML formats.

For more information, please refer to the information in the default template file. When selecting this option the *Tool list template* field (below) will display the location of the template file.

Click on the *Edit tool list template* button () to open the template and follow the instructions described within the file.

Please see the section *Advanced Configuration (HTML Tool List)* below for an example of how to create a HTML based tool list.

Tool trigger

Use this field to specify the tool trigger for the selected *File Type*. This is the character or string that CIMCO

Edit will match and identify as a tool in the NC program.

For instance, if your machine uses T01 for tool 01, specify T in this field.

You can also use a Regular Expression by clicking the icon on the right side of the field and selecting *Advanced*. See [Regular Expressions](#) for more information.

\$TOOL1 / \$TOOL2 Trigger

Use these fields to specify the advanced trigger that should be used to generate the \$TOOL1/2 variable.

For example, to include the value specified after R in the following line:

T1 5MM DRILL R33

Specify the trigger R<[0-9]+>.

This will assign the value R33 to the \$TOOL1 variable.

Filter comments with advanced trigger

Use this field to specify the advanced trigger (Regular Expression) that should be used to filter (scan) comments. Comment lines are only used if they match the Regular Expression and, by default, CIMCO Edit looks for comment lines above the tool trigger/code.

The comment filter is useful when each tool is surrounded by multiple comments as in the example below:

```
(*****)  
(* BALL MILL D6 *)  
(*****)  
T3
```

If you use the default configuration, CIMCO Edit will extract the following information:

```
T3 *****
```

To get the correct tool description, you can add the following Regular Expression:

```
[A-Z0-9 ]+
```

This ensures that the tool comment includes letters, numbers and spaces. The tool list will then shown:

```
T3 (* BALL MILL D6 *)
```

Sort tool list

Select this option to sort the tool list and only list each tool once.

Ignore duplicate info (T020202 = T02)

Select this option to ignore duplicate/magazine info in the tool number, i.e. T020202 should be listed as T02.

Ignore 0's (T02 = T2)

Select this option to ignore leading zeros in tool numbers, i.e. T02 should be listed as T2.

Two line comments

Select this option if the tool comment consists of two lines.

Scan comments below tool name

Select this option if the tool comment is always located below the tool change line.

Advanced Tool trigger: Scan two lines at a time

Select this option if the advanced tool trigger should scan two lines at a time.

Tool list template

Use this field to specify the path to the tool list template. Click the folder icon to the right  to select a tool list template.

Click the icon  next to the folder icon if you wish to edit the specified tool list template.

Advanced Configuration (HTML Tool List)

CIMCO Edit comes pre-installed with three tool list template files, located in:

C:\Users\\AppData\Roaming\CIMCO 2026\CIMCOEdit\SYS

- **Toollist.txt:** - Simple tool list template
- **NewToolList.txt:** - Advanced tool list configuration template
- **NewToolListHtmlSample.txt:** - Example of advanced tool list with HTML output

To create your own HTML tool list, we recommend starting by making a copy of the template file: 'NewToolListHtmlSample.txt'. Rename the copied file to something meaningful that reflects its purpose.

Before configuring the file, navigate to *Setup > File Types* and select the *file type* where you want the custom tool list to be applied. Once selected, return to the *Tool List* dialog.

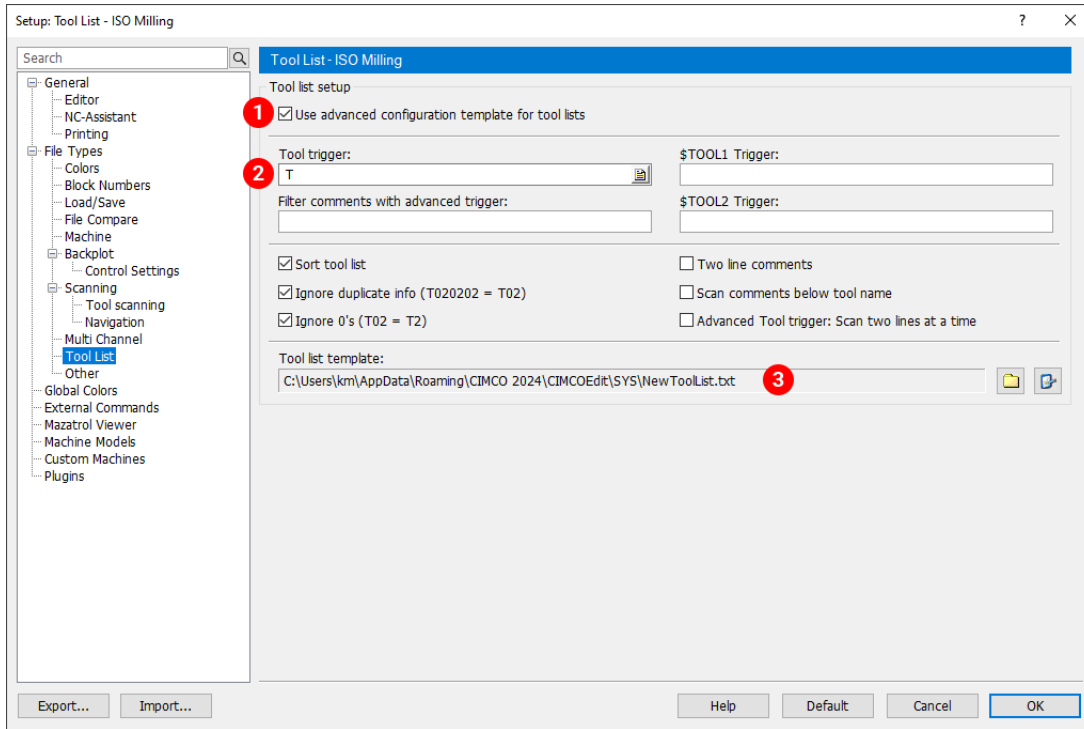

To use the new HTML tool list, configure the dialog the following way:

1. Enable the option *Use advanced configuration template for tool lists*.
2. *Tool Trigger* field: Enter any value here. This field is not used for HTML lists, but must not be left empty — otherwise, an error will be shown indicating the tool list is not configured.
3. *Tool List Template*: This field should point to the full path and filename of your custom HTML template.

Configuration example

Inside the copied template file, you'll find two main sections:

- The first part, between [CONFIG_BEGIN] and [CONFIG_END], contains the configuration settings that control how tool data is extracted and interpreted.
- The second part, beginning with the [HEADER_BEGIN] section, defines the HTML structure used for generating the tool list output.

LOCK_CONFIGURATION=Yes

In the configuration section, set this to 'Yes' to ignore configuration options from CIMCO Edit. The default is 'No'.

In the following we will work with this example code.

```
T="MILL DIAMETER 16"
;C635571          (TOOL ARTICLE SAP CODE)
;2-FLUTE MILL D16  (TOOL DESCRIPTION)
;POHSS-45454     (TOOL HOLDER CODE)
;32 MM           (TOOL PROTRUSION LENGTH)
;TEST1           (TEST VALUE 5)
;TEST2           (TEST VALUE 6)
;TEST3           (TEST VALUE 7)
```

TOOL_TRIGGER_REGEX=

Use `TOOL_TRIGGER_REGEX` to define a regular expression that identifies tool definitions in an NC program. This allows you to match specific patterns and extract tool information such as tool names or IDs.

Important: Ensure that the line `TOOL_TRIGGER=` is left empty.

To extract the tool name from a line like: `T="MILL DIAMETER 16"`, use the following expression:

```
TOOL_TRIGGER_REGEX= T=" ( [[:space:]]0-9a-zA-Z/]+ ) "
```

This will capture the tool name "MILL DIAMETER 16" from the quoted string.

Next, to define which character marks the beginning of a comment in your NC program, use the following setting:

```
COMMENT_START= ;
```

By default, the comment character is set to '`'`. In this case, we set it to '`'`' because all comment lines in the program begin with a semicolon.

All tool-related comments identified by the system are stored in the variable `$TOOLINFO`. To include these comments in the generated HTML output, simply insert `$TOOLINFO` into your template. This will output all matching comment lines without the original comment symbol.

```
NUMBER_OF_COMMENTS= 7
```

If there are multiple comment lines following a tool definition, you must set `NUMBER_OF_COMMENTS` to match the total number of lines you want to capture. In this example, there are 7 comment lines.

To extract each comment into a separate variable, you need to define each line individually by repeating and adjusting the following section in your configuration file accordingly. This allows you to reference each comment line separately in your HTML output with variables `$INFO1`, `$INFO2`, etc.

```
[EXTRACT_FROM_TOOL_COMMENT_BEGIN]
#Name of variable (only $A-Z0-9 allowed)
VARIABLE= $INFO1

#Regular expression used to extract the text
EXTRACT_REGEX= ^([[:alnum:]]-)+[[:space:]]*\ (TOOL ARTICLE SAP CODE\)$
[EXTRACT_FROM_TOOL_COMMENT_END]
```

To include an image in the HTML output, simply use standard HTML `img` syntax. For example:

```

```

Make sure the image file (e.g., `Logo.jpg`) is located in the same folder as your tool list template or accessible via a valid path.

To test the template, save your changes to the template file. Then open an NC file in CIMCO Edit and ensure the correct *File Type* is selected. Then go to the *NC Functions* tab and click the option *Make Tool List*. This will generate the HTML code output in a new file tab.

This will generate the HTML output in a new tab within CIMCO Edit. You can then save it with a `.html` file.
CIMCO Edit 2026 User Guide

extension and open it in a browser to view your tool list, complete with any images and formatting you've applied.

7.2.10. Other

The *Other* section allows you to configure general settings for printing and exporting to DXF.

The settings in this section only apply to the selected *File Type*. If you wish to configure a different File Type, go to the [File Type](#) section, change the type, and then revisit this section to continue. You can see the current File Type at the top of the dialog.

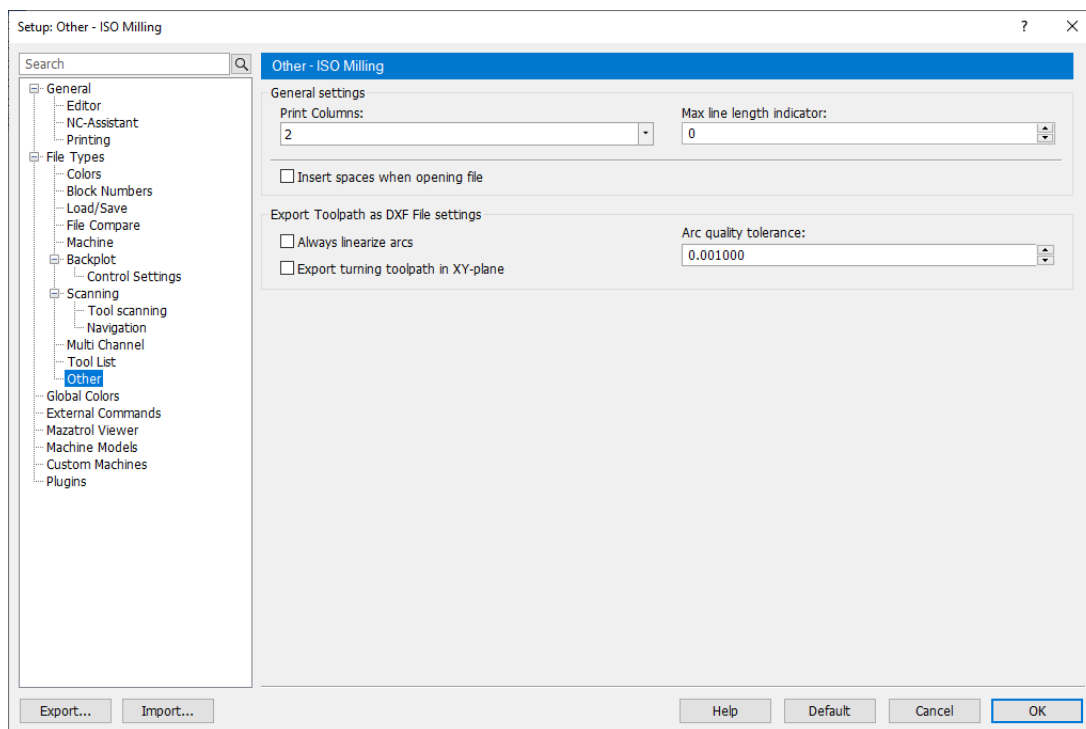

Other dialog.

General Settings

Print Columns

Use this dropdown to select the number of columns that should be used when CNC programs of the selected file type are printed.

Max line length indicator

Use this field to set the position of the Max line length indicator.

If you are using a proportional font (i.e. all letters are not the same width), the indicator does not show the exact line length.

Insert spaces when opening file

Select this option to automatically insert spaces when opening a file.

Export Toolpath as DXF File Settings

Always linearize arcs

Select this option to convert all arcs in the toolpath to a series of linear segments in the exported DXF file. This can be useful if the receiving system or software does not support arc interpolation.

Export turning toolpath in XY-plane

This setting is specific to turning operations. When you export a turning toolpath, this setting ensures that the toolpath is projected onto the XY-plane in the DXF file. This is important because turning typically involves movements in the XZ-plane, but for visualization and compatibility with certain CAD systems, you might need it on the XY-plane.

Arc quality tolerance

The allowable deviation from the ideal arc path when exporting a toolpath as a DXF file. It determines how closely the exported arcs need to match the original NC program's arcs.

7.3. Global Colors

The *Global Colors* section allows you to configure general colors for the simulation versions and the CIMCO CNC-Calc add-on.

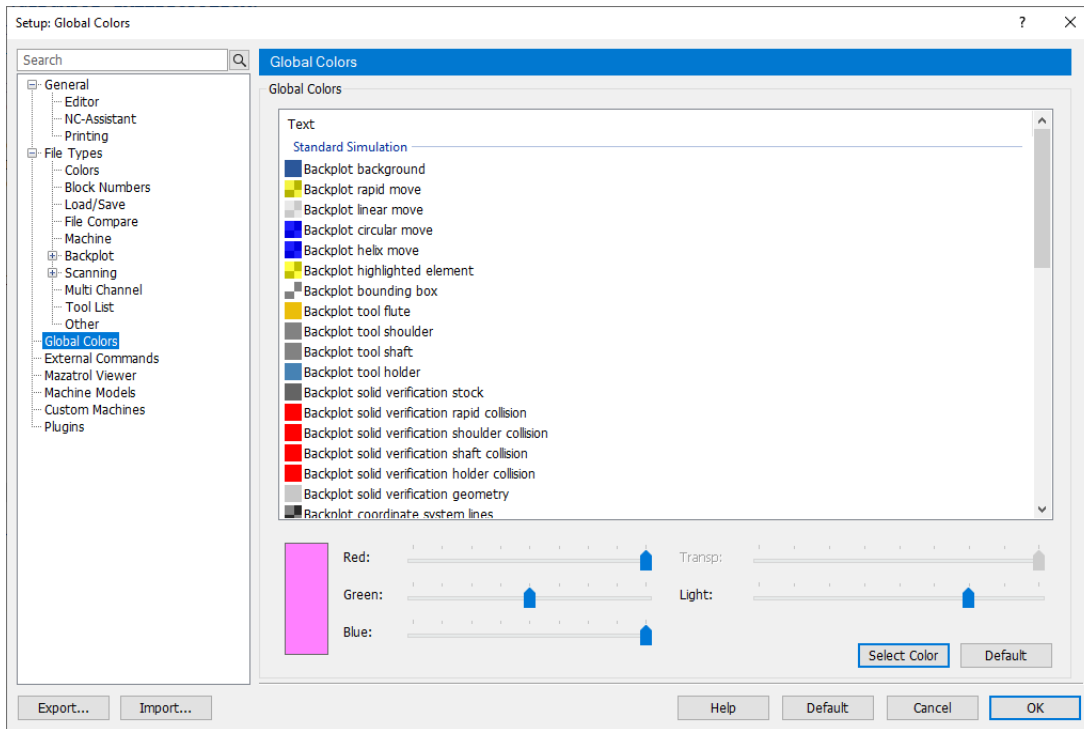

Global Colors dialog.

Global Colors



List of Colors

This field lists all the colors that can be configured. Select a color to change it using the sliders at the bottom of the dialog or double-click to use the *Color* dialog.



Select Color

Click this button to open the *Color* dialog where you can select from predefined colors or create custom colors.



Default

Click this button to change the selected color back to the default color.

7.4. External Commands

The *External Commands* section allows you to configure two external commands which can be executed directly from a menu in the *NC Functions* tab. External Commands are essentially command-line calls.

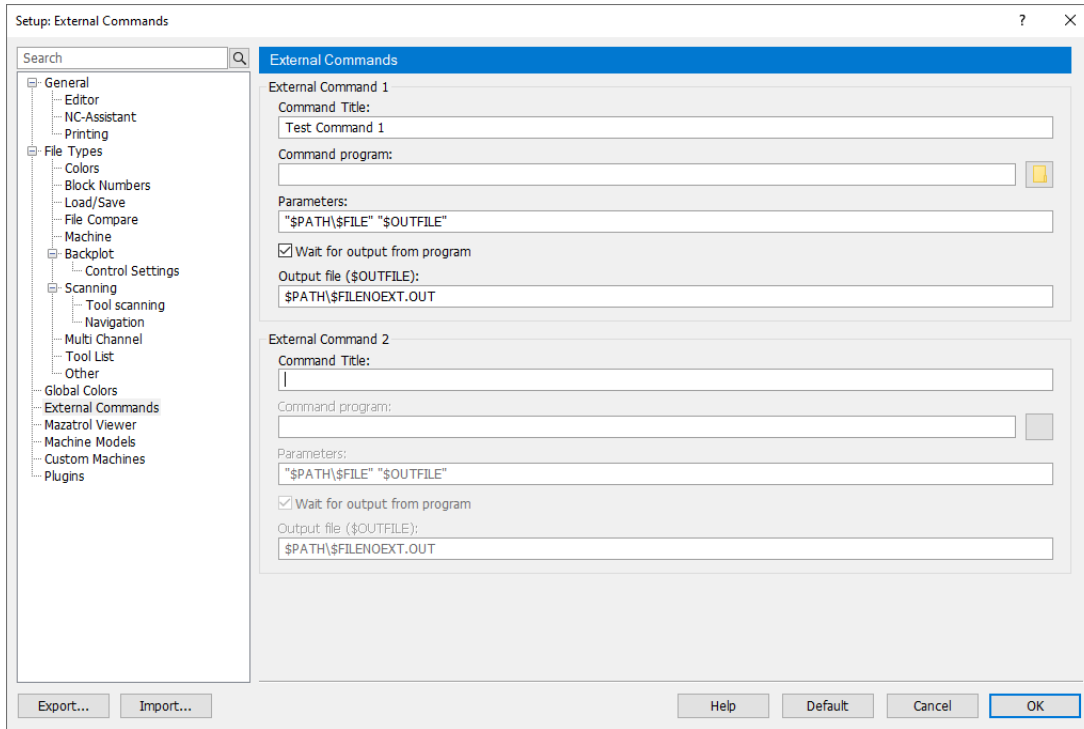

External Commands dialog.

External Command 1 and 2

abc **Command Title**

Use this field to specify a title for the External Command. An option to activate the External Command will be added to the *Commands* menu under the *NC Functions* tab. The text in this field will be used for this command.

abc **Command program**

Use this field to select the application that the command should execute. You can click the folder icon  to browse for the executable file.

abc **Parameters**

Use this field to specify the parameters for the command. These are the command-line parameters that will be appended to the executable selected in the *Command program* field.

The following variables are available:

- \$FILE: Defines the file name without path.
- \$FILENOEXT: Defines the file name without extension.
- \$PATH: Specifies the path of the file.
- \$FILEPATH: Specifies the file name with path.
- \$OUTFILE: Name of the output file as defined below.

For example, to execute the command with the parameters:

```
-g C:\NCPRG\MOULD.NC C:\NCPRG\MOULD.NEW
```

enter the following:

```
-g $FILE $OUTFILE
```

and then, in the *Output file* field below, enter:

```
$PATH\$FILENOEXT.NEW
```

Output file (\$OUTFILE)

Use this field to specify the name of the output file. The following variables are available:

- \$FILE: Defines the file name without path.
- \$FILENOEXT: Defines the file name without extension.
- \$PATH: Specifies the path of the file.
- \$FILEPATH: Specifies the file name with path.

See example above.

If no output filename is specified, it is assumed that the input file is modified.

7.5. Mazatrol Viewer

The *Mazatrol Viewer* section allows you to configure how Mazatrol files should be displayed and associate specific file extensions with Mazak CNC controls.

The Mazatrol Viewer only allows you to view and print Mazatrol binary files (without header information). It is not possible to make changes or save a file back to its original binary format.

The Mazatrol Viewer is an add-on for CIMCO Edit. It is purchased separately and requires a valid license. The Mazatrol Viewer add-on can be enabled under [Plugins](#).

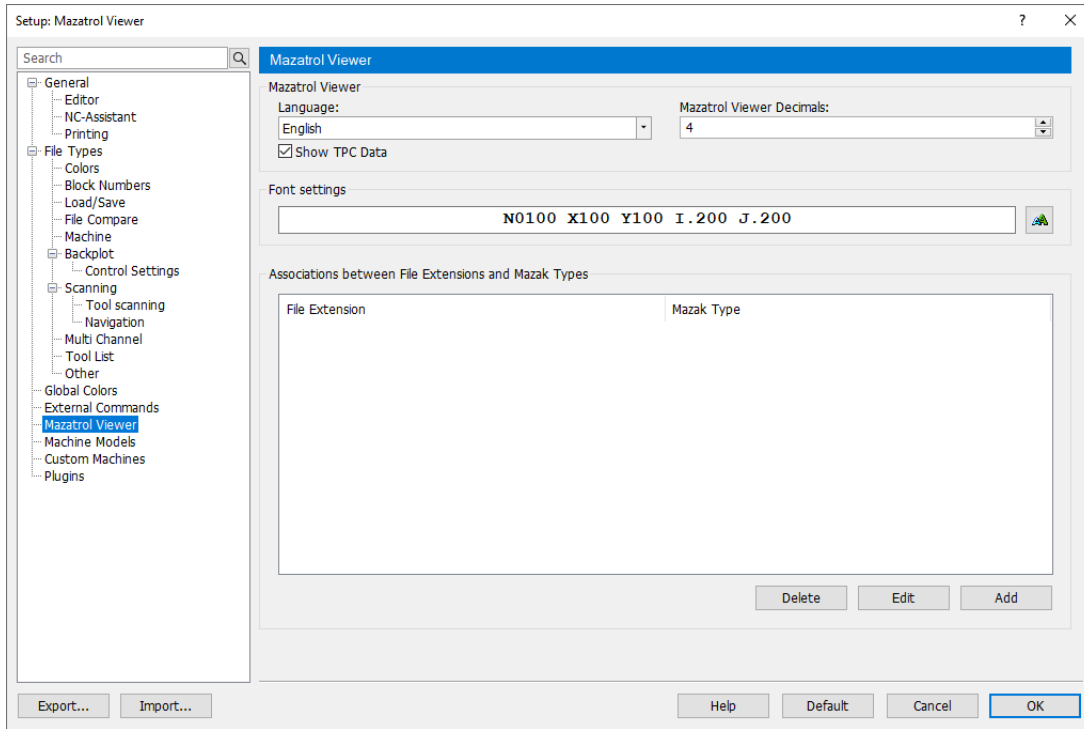

Mazatrol Viewer dialog.

Mazatrol Viewer

Language

Use this dropdown to select the language used when displaying the Mazatrol data.

Mazatrol Viewer Decimals

Use this field to specify how many decimals should be used to display values in the Mazatrol Viewer.

Show TPC Data

Select this option to include TPC data when viewing Mazatrol files.

Font settings

Preview field

This field shows an example of the selected font. Click on the font button to the right to select another font.

Associations

List of Associations

Use this field to associate specific file extensions with Mazak CNC controls. Use the buttons *Delete*, *Edit*, and *Add* to manage associations in the list.

7.6. Machine Models

The *Machine Models* section is only visible when the Machine Simulation add-on is activated. The dialog allows you to conveniently download and install machines for use with Machine Simulation.

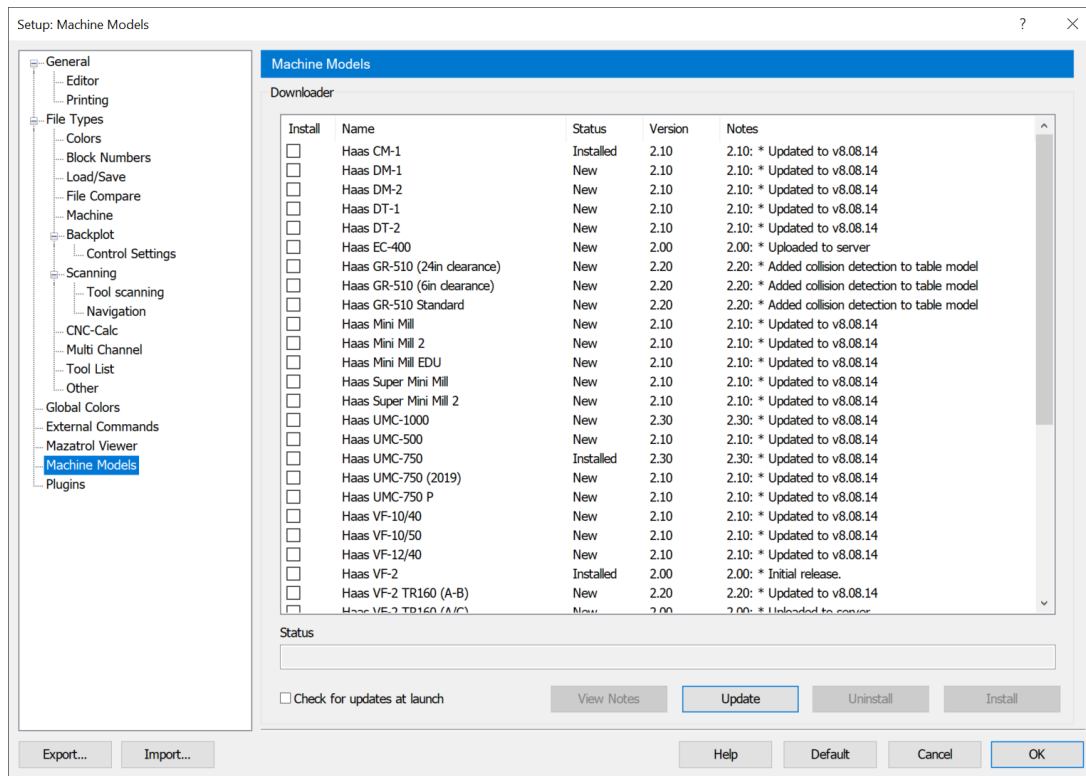

Machine Models dialog.



List of Machines

This section lists all the available machines that can be downloaded. Click the *Update* button to list machines or to reload the list.

To install a machine, enable its checkbox in the *Install* column and click the *Install* button at the bottom of the dialog. A similar approach is used for uninstalling or viewing a machine's release notes.

Description of columns:

- **Install:** Checkboxes to select machines
- **Name:** Name of machine
- **Status:**
 - **New:** Machine is not installed
 - **Installed:** Machine is installed
 - **Update:** Update available for installed machine
- **Version:** Machine version
- **Notes:** Machine version and latest note



Check for updates at launch

Select this field to get a notification about updated machines when launching the CIMCO Edit.

View Notes

Click this button to view all modifications that have been made to the selected machine.

Update

Click this button to list machines or to reload the list.

Uninstall

Click this button to uninstall all the selected machines.

Install

Click this button to install all the selected machines.

7.7. Custom Machines

The *Custom Machines* section allows you to create, configure and manage custom machine configurations.

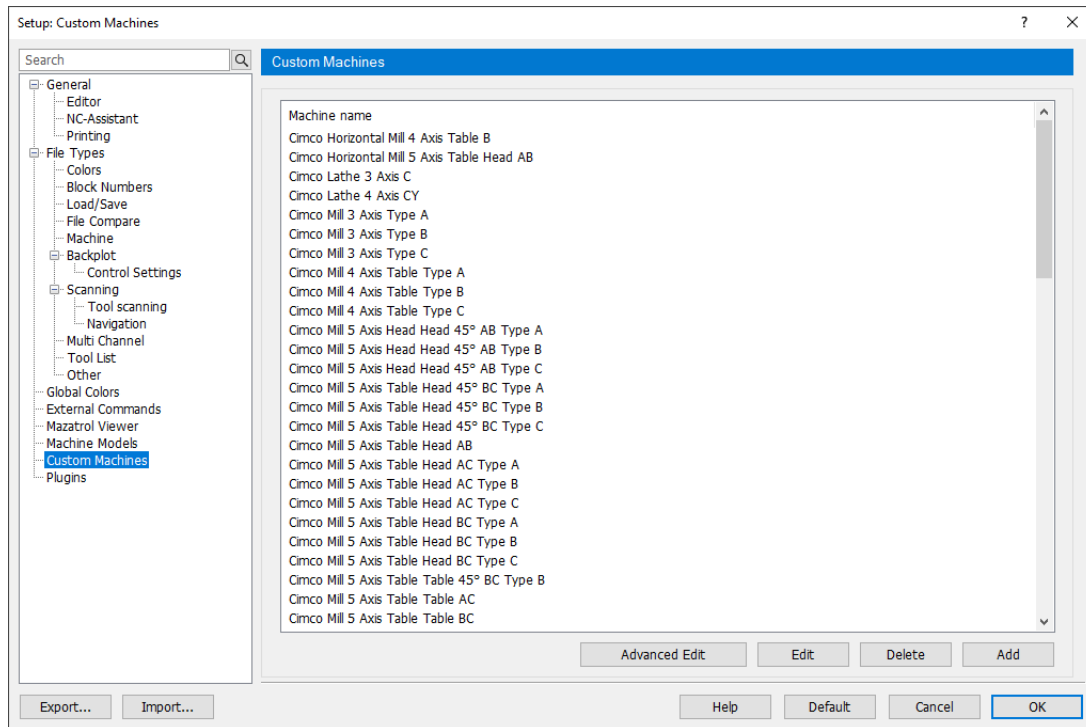

Custom Machines dialog.



List of Machines

This section lists all available custom machines.



Advanced Edit

Click this button to open the [Advanced Machine Configuration Editor](#) for the selected machine.



Edit

Click this button to open the [Machine Configuration Editor](#) for the selected machine.

You can also create new machines directly using this editor.



Delete

Click this button to delete the selected machine.



Add

Click this button to add a new machine. The following dialog will appear:

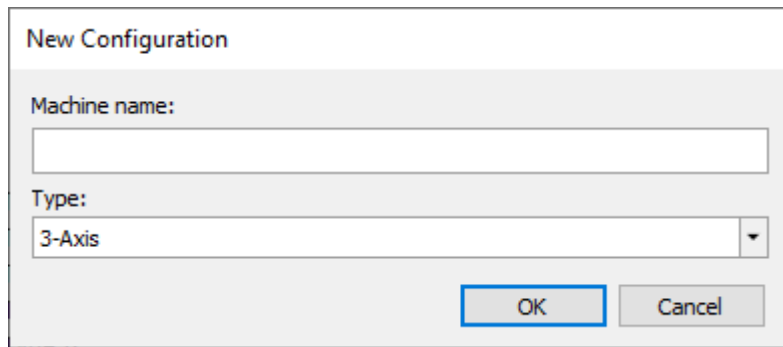

The image shows a dialog box titled "New Configuration". It has a light gray background and a white border. At the top, the title "New Configuration" is displayed in a bold, black font. Below the title, there are two main sections. The first section is labeled "Machine name:" and contains a single-line text input field. The second section is labeled "Type:" and contains a dropdown menu with "3-Axis" selected. At the bottom right of the dialog, there are two buttons: "OK" and "Cancel". The "OK" button is highlighted with a blue border.

- **Machine name:** The name of the new machine
- **Type:** Select number of axes and rotational setup:
 - **3-Axis:** three linear axes
 - **4-Axis Head:** adds a rotational axis to the head
 - **4-Axis Table:** adds a rotational axis to the table
 - **5-Axis Head / Head:** adds two rotational axis to the head
 - **5-Axis Head / Table:** adds a rotational axis to the head and table
 - **5-Axis Table / Table :** adds two rotational axis to the table

These settings can also be changed in the editor afterwards if needed.

After clicking the *OK* button the [Advanced Machine Configuration Editor](#) will open where you can begin to configure the new machine.

The 'Advanced' part of the editor's name refers to its ability to create most of the setup automatically for the user.

7.7.1. Advanced Machine Configuration Editor

The *Advanced Machine Configuration Editor* provides an efficient and intuitive interface for configuring different types of machine configurations. The 'Advanced' part of its name refers to its ability to create most of the setup automatically for the user.

With this editor, you have the advantage of visualizing the machine in real-time as you apply configurations, simplifying the process of observing the effects of modifications. It also automatically calculates the machine kinematics, adapting to the configured axes arrangement.

While this editor is designed for ease of use and will suit most needs, it is not capable of configuring complex features like collinear axes, revolvers, and spindles. These setups can be achieved using the [Machine Configuration Editor](#).

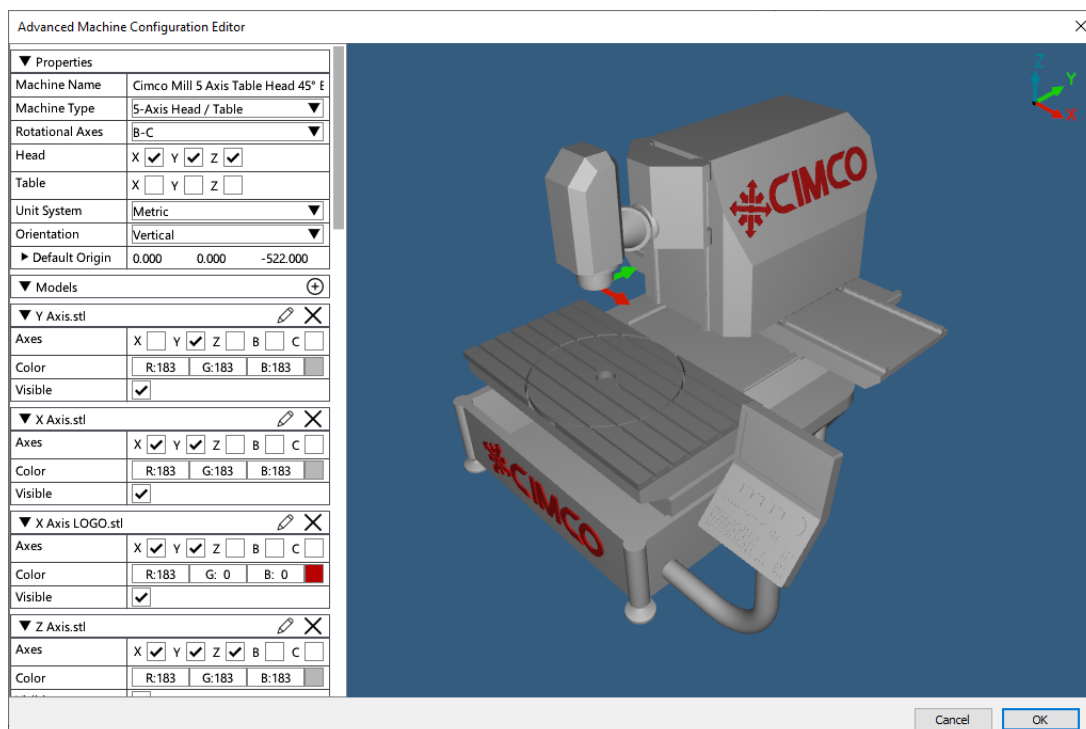

Advanced Machine Configuration Editor dialog.

The editor is structured with a settings panel on the left for configuration options and a machine preview on the right that visually reflects changes in real-time.

You can right-click anywhere in the preview to change or reset the view.

Settings Panel

The settings panel contains the following sections:

▼ Properties

This section contains general settings, including the machine's name, type, unit system, and the configuration of axes for both Head and Table components.

Models

This section contains a list of STL models with axes assignment, model color and visibility. Click the (+) sign to add an STL model.

Axes

This section lists the axes as defined by the machine type. You can set the *Travel limit* (min/max), *Feedrate* and *Position* for each axes.

You can preview the movement of the associated STL model with the axis. Clicking the play button animates the *Position* back and forth within the min/max *Travel limit*.

Tool Change Positions

This section defines the sequence in which the machine's axes move towards the tool change location. Each axis is set by choosing its order (1st, 2nd, 3rd, etc.) and the target position.

The movement begins with the axis labeled *1st*, followed by *2nd*, and continues in this manner, providing precise control over the machine's motion.

NC-Commands

Use this field to inject and execute an NC code when a tool change occurs.

7.7.2. Machine Configuration Editor

The *Machine Configuration Editor* provides a clean and intuitive interface for configuring different types of machine configurations.

It enables users to add geometry to individual machine component and specify the machine's axis components, movement limits, feedrates, and the tool change location. Additionally, it supports complex configurations such as collinear axes, revolvers, and spindles.

The layout of the editor is divided into three sections: a list of machines on the left, the configuration of components and axes at the center, and the properties section on the right.

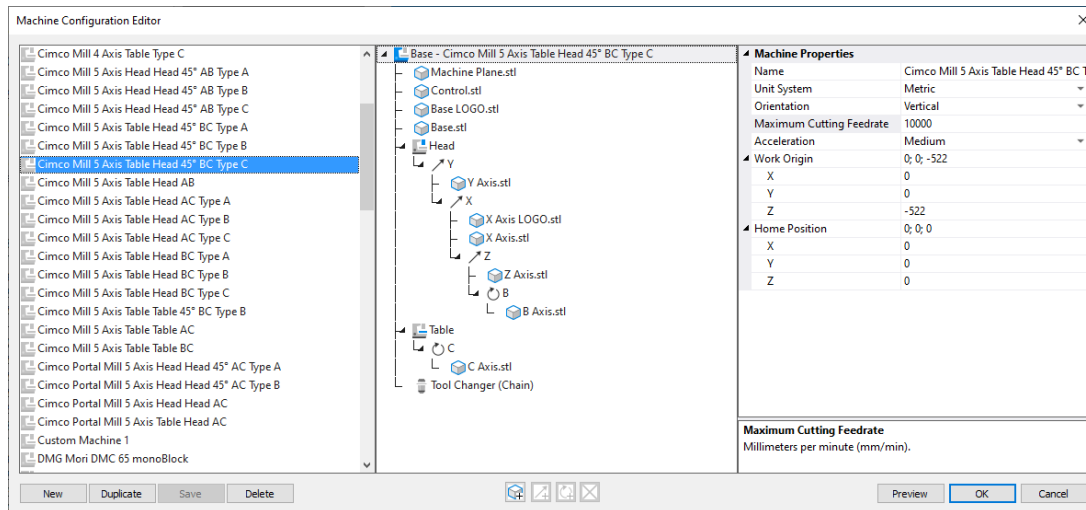

Main configuration window.

In addition, the editor includes the *Machine Preview* (accessible via the *Preview* button). You cannot see the preview while editing a configuration, but for an improved experience, you can resize the preview to a smaller scale and place it beside the main editor window. The preview maintains its size and appear in the same location each time you click the *Preview* button.

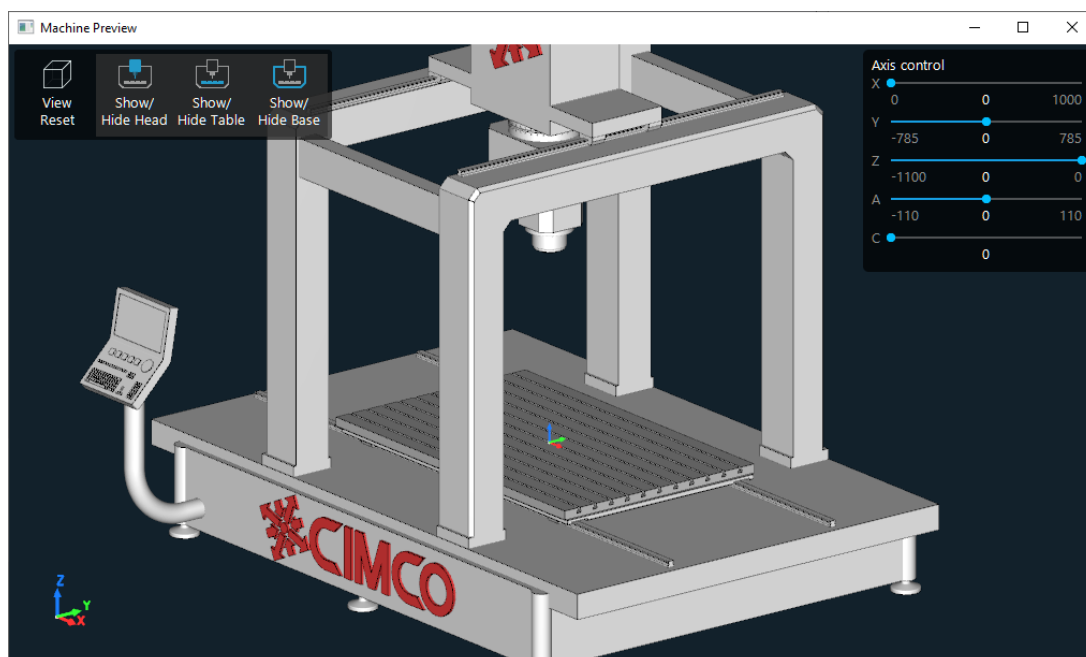

Machine Preview window.
CIMCO Edit 2026 User Guide

List of Machines



List of Machines

This field shows a list of all machine configurations.

Select a machine to see its configuration in the center section. The buttons below the field also apply to the selected machine configuration.

Right-click menu contains options for creating, saving and deleting machine configurations.

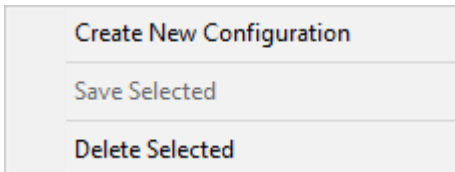

New

Click this button to add a new machine configuration.

Duplicate

Click this button to make a copy of the selected machine configuration.

Save

Click this button to save the selected machine configuration.

If the machine icon is red, this indicates there are errors that need resolving before you can save. A green icon indicates that the configuration is error-free and ready for its initial save.

Machine configurations are saved in the directory:

`\AppData\Roaming\ ... CIMCO Edit install dirs ... \MachineCfg\`

Delete

Click this button to delete the selected machine configuration.

Component and Axes configuration

Machine configurations use a hierarchical tree structure to represent the relationship between components.

Select any component to see its properties on the right side of the dialog.

The four buttons at the bottom of the dialog can be used to add geometry, add a linear or rotational axis, or to delete a component. The buttons are activated to reflect the options available for the selected component, but does not include all options available.



Instead, you can right-click any component to see *all* the available options, including additional options for *Add Collinear Axis*, *Add Spindle* and *Add Turret*.

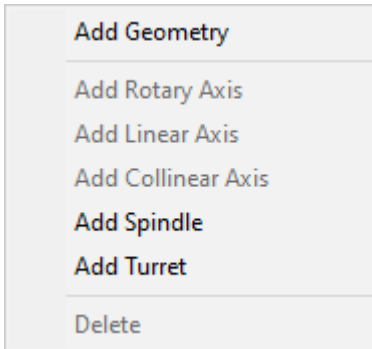

Base

The *Base* component serves as the foundation of the machine. It is the root component of the *Head*, *Table*, *Tool Changer*, and other components.

Base contains the following properties:

- **Name:**
Name of machine configuration.
- **Unit System:**
The Unit System (Metric/Imperial) used in the configuration for property values such as positions, limits and feedrates.
- **Orientation:**
Use this setting to specify the orientation of the machine configuration.
- **Maximum Cutting Feedrate:**
Defines the highest allowable cutting speed at which the tool moves through the material. Measured in millimeters per minute (mm/min).
- **Acceleration:**
The rate at which the machine's axes can change speed. It determines how quickly the machine can reach its maximum feedrate or decelerate to a stop. Options include: Slow, Medium and Fast.
- **Work Origin:**
Default position on the machine where Workpiece, Fixture, and Stock will be placed. Defined relative to the machine zero position (spindle nose).
- **Home Position:**
The Home Position refers to the location defined by G53 (ISO) or M91 (Heidenhain). It is common

practice to offset the machine STL files so that this position aligns with (0,0,0) in the coordinate system.

Head

The *Head* component represents the head of the machine where the spindle and tool holder are located. In the editor, it functions primarily as a structural element, providing a container for the child components (axes and geometry) that define the head's configuration.

Table

The *Table* component represents the table of the machine where the workpiece is secured. In the editor, it functions primarily as a structural element, providing a container for the child components (axes and geometry) that define the table's configuration.

Rotary Axis

A *Rotary Axis* represents an axis of rotation, defined by its orientation with respect to the X, Y, and Z axes. It provides a pivot point around which the machine components can rotate.

Contains the following properties:

- **Address:**
Select a rotary axis A, B or C.
 - **Limits:**
Minimum and maximum travel limit values in degrees.
 - **Feedrate:**
The maximum feedrate to be used in rapid movements. For a rotary axes this must be defined in degrees per minute (deg/Min).
 - **Direction:**
This is set automatically, but can be adjusted if necessary. Defines the direction around which the axis will rotate.
 - **Centre of Rotation:**
Defines the X, Y, Z origin for the axis of revolution.
-

Linear Axis

A *Linear Axis* represents a linear axis in X, Y or Z along which the machine components can move.

Contains the following properties:
CIMCO Edit 2026 User Guide

- **Address:**

Select a linear axis X, Y or Z.

- **Limits:**

Minimum and maximum travel limit values. The values must always be relative to the position of the axes when set to their machine zero position.

- **Feedrate:**

Input the feedrate of the axis. This is the maximum feedrate to be used in rapid movements. For linear axes this value will need to be in millimeters per minute (mm/Min).

- **Direction:**

Automatically set but can be adjusted if necessary. Defines the direction in which the axis will move along.

Collinear Axis

A *Collinear Axis* can be used to define multiple axes that are oriented in the same direction. It can be used in situations where several moving parts must be aligned along a common line.

Contains the following properties:

- **Address:**

Select a linear axis U, V or W.

- **Limits:**

Minimum and maximum travel limit values. The values must always be relative to the position of the axes when set to their machine zero position.

- **Feedrate:**

Input the feedrate of the axis. This is the maximum feedrate to be used in rapid movements. This value will need to be in millimeters per minute (mm/Min).

- **Direction:**

Automatically set but can be adjusted if necessary. Defines the direction in which the axis will move along.

Geometry

The *Geometry* component represents an STL model. Any component (Base, Head, Table, Axes, Tool Changer) can have multiple *Geometry* components added. A *Geometry* component will follow the movement and rotation of its parent component.

Contains the following properties:

- **File Path:**

The path to the STL model file. Model files are copied to the configuration directory after saving and exiting the editor.

- **Unit System:**

The measurement unit system used in the STL model. A wrong unit system will result in the STL model's scaling not being correct.

- **Color:**

The color of the model represented in RGB with a value between 0-255.

When creating your own models, the geometry (CAD Model/STL models) of a machine must be set in relation to the machine zero position and the origin set to the tip of the spindle nose.

Tool Changer (Chain)

The *Tool Changer (Chain)* component defines the sequence in which the machine's axes move towards the tool change location. Each axis is set by choosing its sequence (order) (1st, 2nd, 3rd, etc.) and the target position.

The movement begins with the axis labeled 1st, followed by 2nd, and continues in this manner, providing precise control over the machine's motion.

Contains the following properties:

- **Sequence:**

Defines the sequence in which the axis will move.

- **Position:**

Defines the position on the axis.

- **NC-Commands:**

Use this field to inject and execute an NC code when a tool change occurs.

Tool Changer (Turret)

The *Tool Changer (Turret)* component defines a rotating tool-holding component that allows for rapid switching between multiple different cutting tools. It is also sometimes referred to as a *revolver*.

Contains the following properties:

- **Mount Axis:**
Defines which direction is up on the turret.
- **Direction:**
The revolution axis of the turret.
- **Center:**
The center of rotation for the turret slots.
- **Number of Slots:**
Defines the number of slots in the turret. The individual slots are listed below this property.
- **Slot (1-64):**
The position of an individual slot defined by X, Y, Z.

Tool Mount (Turret)

The *Tool Mount* component defines the configuration of the component on the turret (revolver) that securely holds the cutting tool in position.

Machine Preview

The *Machine Preview* shows the machine in 3D. You can navigate the simulation using rotate (click and hold left mouse button), zoom (mouse scroll wheel), and pan (click and hold right mouse button).

Additionally, you toggle the visibility of components (Head, Table, and Base) and test the travel limits of each axis using the *Axis Control* panel.

7.8. Plugins

The *Plugins* section allows you to activate or deactivate certain options, modules, and add-ons. It also provides the option to secure the Editor Setup with a password and modify the paths for the default configuration directories.

CIMCO Edit must be licensed according to the plugins you wish to use in the editor.

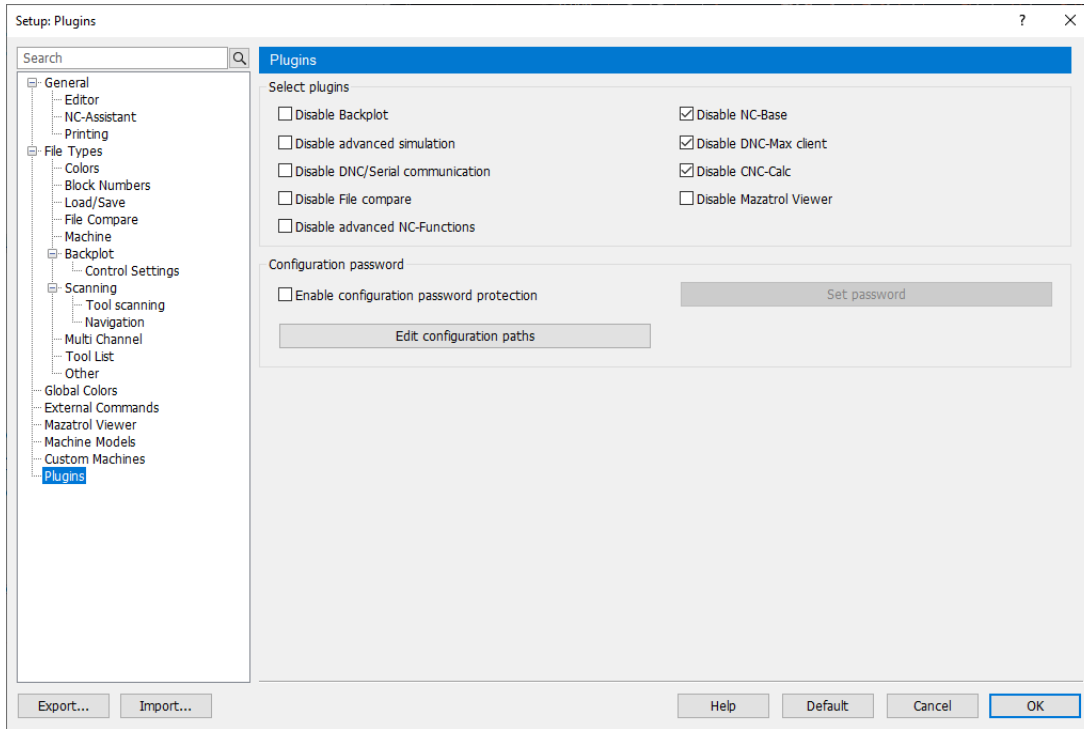

Plugins dialog.

Select Plugins

Disable Backplot

Select this option to disable the backplot/simulation. This will remove the *Backplot* tab.

Backplot requires a CIMCO Edit Professional license.

Disable advanced simulation

Select this option to disable advanced simulation options such as solid simulation. This will remove the *Solid* menu under the *Backplot* tab.

Disable DNC/Serial communication

Select this option to disable the DNC/Serial communication module.

Requires a license for DNC-Option.

Disable File compare

Select this option to disable the File compare function. This will remove the *File Compare* tab.

Disable advanced NC-Functions

Select this option to disable the advanced NC functions. This will remove the *Transform* and *Info* menus and their options under the [NC Functions](#) tab.

Advanced NC functions requires a CIMCO Edit Professional license.

Disable NC-Base

Select this option to disable the NC-Base Client (if installed along with NC-Base Server).

Requires an extended license for CIMCO Edit.

Disable DNC-Max Client

Select this option to disable the DNC-Max Client (if installed along with NC-Base Server and DNC-Max Server).

Requires an extended license for CIMCO Edit.

Disable CNC-Calc

Select this option to disable the CNC-Calc module.

CNC-Calc requires an extended license for CIMCO Edit Professional.

Disable Mazatrol Viewer

Select this option to disable the Mazatrol Viewer module.

Mazatrol Viewer requires an extended license for CIMCO Edit.

Configuration Password

Enable configuration password protection

...

Set password

Click this button to specify a password required for accessing the Editor Setup and its configuration.

If you forget the password, hold down *Ctrl+Shift* when you start the editor.

Edit configuration paths

Use this option to change the location and directories that CIMCO Edit uses for various configuration files.

Use the dropdown field to select a path and the field below to change it.

You can choose to copy the existing configuration files to the new directory or revert to the default configuration if needed.

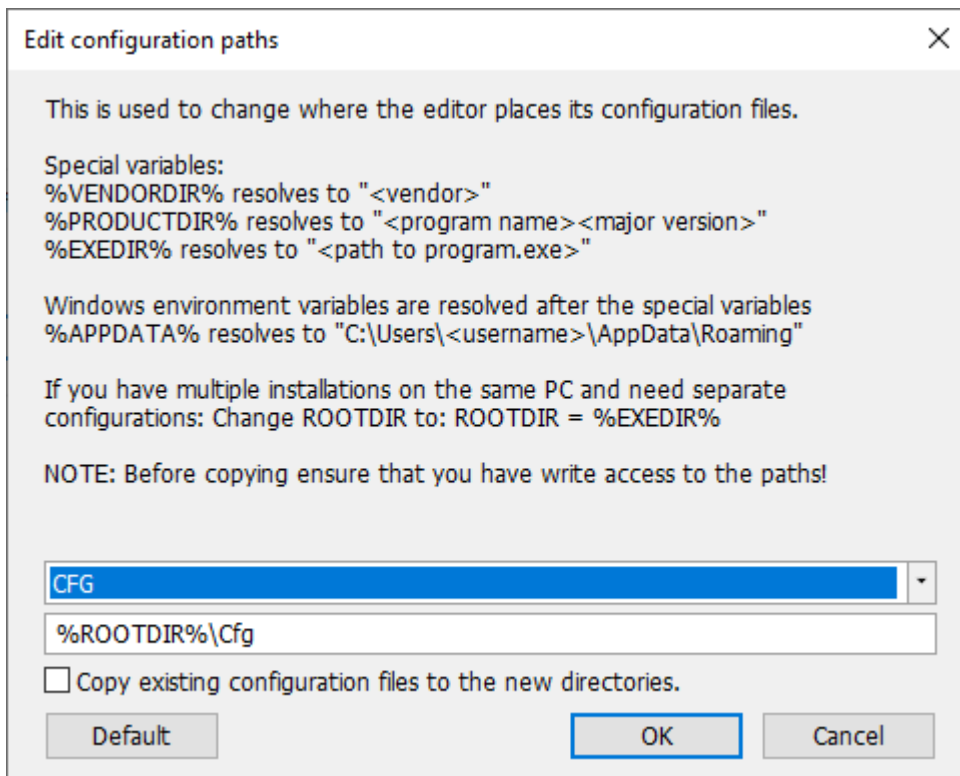

8. Regular Expressions

The regex used in CIMCO Edit is based on POSIX Extended Regular Expression, with some simplifications.

You can read more about POSIX Extended Regular Expression (ERE) online:

- https://en.wikipedia.org/wiki/Regular_expression
- https://en.wikibooks.org/wiki/Regular_Expressions/POSIX-Extended_Regular_Expressions

Syntax

Metacharacter	Description
.	Dot character matches any character. For example, "A.C" Matches "A" followed by any character and then a "C". To match the literal "." character use a backward slash \. or bracket expression [.]
^	Matches the starting position of the line. For example, "G123" matches the character sequence "G123" anywhere on the line, "^G123" only matches "G123" if located at beginning of the line. To match the literal "^" character use a backward slash "\^" outside of bracket expressions.
\$	Matches the ending position of the line. For example, "G123" matches the character sequence "G123" anywhere on the line, "\$G123" only matches "G123" if located at the end of the line. To match the literal "\$" character use a backward slash "\\$" outside of bracket expressions.
[]	Bracket expression. Matches any of the characters within the brackets. For example, "[AZ]" matches one of the characters "A" or "Z". A range can be specified by using "-". E.g. "[A-Z]" matches any character in the range from "A" to "Z" and "[4-7]" matches any number from "4" to "7". To match the literal "[" or "]" character use a backward slash [or] outside of bracket expressions.
[^]	Matches any character not within the brackets. For example, "[AZ]" matches any character other than "A" or "Z". A range can be specified by using "-". E.g. "[A-Z]" matches any character other than the letters from "A" to "Z" and "[4-7]" matches any other than the numbers from "4" to "7".
*	Matches the preceding element zero or more times. For example, "G[0-9]*" matches "G" followed by zero or more numbers between "0" and "9". To match the literal "*" character use a backward slash "*" or bracket expression "[*]".
+	Matches the preceding element one or more times. For example, "G[0-9]+" matches "G" followed at least one number between "0" and "9". To match the literal "+" character use a backward slash "\+" or bracket expression "[+]".
?	Matches the preceding element one or zero times. For example, "AB?C" matches the sequence "ABC" or "AC". To match the literal "?" character use a backward slash "\?" or bracket expression "[?]".
	Matches the preceding or the following element. For example, "AB C" matches "AB" or "AC". To match the literal " " character use a backward slash "\ " or bracket expression [].

Metacharacter	Description
{n}	Matches the preceding element exactly n times. For example, "A{3}" matches "AAA".
{n,}	Matches the preceding element minimum n times. For example, "A{3,}" matches any character sequence with at least three "A"s.
{,m}	Matches the preceding element maximum n times. For example, "A{,3}" matches any character sequence with at maximum three "A"s.
{m,n}	Matches the preceding element at least n and not more than m times. For example, "A{2,4}" matches any character sequence with at minimum two and maximum four "A"s.
()	Grouping. Matches the group of characters within the brackets. For example, "(G[1-3]) (M[4-7])" matches "G" followed by a number between 1 and 4 or matches "M" followed by a number between 4 and 7.
<>	Capture. Matches the subexpression within the brackets. For example. "G<[0-9]+>" matches one or more numbers following "G", excluding "G" from the match.

9. Using Editor Help

This section describes how to use the help system in CIMCO Edit.

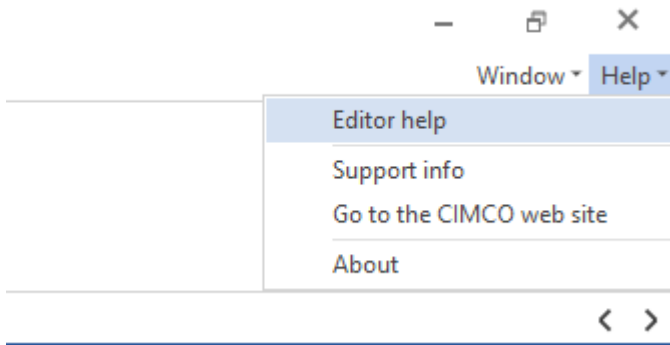

Help menu.

Editor help

The CIMCO Edit User Guide is available directly in CIMCO Edit as a standard Windows® Help file. You can open the help by going to the *Help* dropdown menu in the upper right corner of the editor and select *Editor help*.

If the help file is not available in your language, it will open the default English help file.

Support info

Select this option to see who to contact for support.

Go to the CIMCO website

Select this option to open the CIMCO website in the default browser.

About

Select this option to open the *About* dialog.

9.1. Using Help in Dialogs

Many dialogs throughout CIMCO Edit has a built-in help feature that provides information about specific options and fields.

Look for a question mark icon in the top-right corner of a dialog. Clicking it allows you to then select any option or field to view a brief explanatory note near your cursor.

You can also display the note for a dialog item by clicking in the field and then pressing the F1 key.

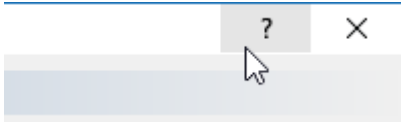

Question mark and cursor.

10. Pending Updates to Documentation

The following changes to CIMCO Edit 2026 are currently not described in the documentation.

CIMCO Edit 2026.01.09

- New: Added simulation shortcut for going to end (Ctrl + Shift + Space).
- New: Added simulation shortcut for playing / pausing (Ctrl + Shift + R).

CIMCO Edit 2026.01.07

- New: New real-time based simulation animation speed slider.
- New: Added gage point to custom lathe holders.

CIMCO Edit 2026.01.03

- New: Added Clamp/unclamp time settings.
- New: Advanced Chuck Jaw setup.
- New: Statistics can show graph for selected tools. (S27148)
- New: Default view can now be changed in the machine configuration editor.
- New: Now bundles external sub programs in simulation bundles.
- New: Support vertical milling extenders.

CIMCO Edit 2026.01.01

- New: Command line (--savebundle path) for saving simulation bundle.

CIMCO Edit 2025.01.30

- New: Turning holder / stock collision detection.
- New: Now remembers tool colors.
- New: Added 'Remove chips' simulation setting.
- New: Stock compare now uses 5 colors.
- New: Gradient toggle in stock compare.

CIMCO Edit 2025.01.28

- New: Showing currently called subprogram's code in fast simulation. (S23299)
- New: Added color picker to tool assemblies.
- New: Toolpath color by tool now supported in the fast simulation window.

CIMCO Edit 2025.01.22

- New: Fanuc milling reverse post: Blum probing cycles. (S23776)
- New: Redesigned the Bookmarks dialog with a cleaner multi-column layout, built-in filtering, and easier navigation. New: Redesigned the Find All Search Results dialog with a cleaner multi-column layout, built-in filtering, and - easier navigation.
- New: Workpiece geometry can now be added from the ribbon bar.
- New: Fixture geometry can now be added from the ribbon bar.
- New: Added show/hide workpiece to the ribbon bar.
- New: Added show/hide fixture to the ribbon bar.
- New: Can now toggle stock visibility in the ribbon bar.

- New: Haas milling reverse posts: G47.
- New: Added cross section toggle to the ribbon bar.
- New: .setup files now specify unit system for WCS and stock.
- New: Added fusion360 native mouse mapping.
- Change: Updated Korean simulation translations.
- Change: Improved performance and responsiveness when searching, updating bookmarks, and handling large files.
- Change: Improved performance of regex-based searches.
- Change: "Search all" can now be used together with "Bookmark All" in the Find dialog.
- Change: The "Match whole string" option is now disabled when "Use regular expression" is enabled in the Find dialog. Change: Printing of multi-channel NC programs in the Editor now supports color output, respecting syntax - highlighting and multi-column printer font settings. (S26459)
- Change: Moved toolpath bounding box and toolpath origin dropdown items to the toolpath ribbon bar split button.
- Change: Grouped show plot control and machine origin with show axis control.
- Change: Removed Zoom in/out buttons from Backplot ribbon bar.
- Change: Combined Zoom Window and Reset Zoom into one ribbon bar button.

CIMCO Edit 2025.01.21

- New: Added goto next/prev navigation when in animation navigation mode.

CIMCO Edit 2025.01.20

- New: Added Cutter Point Shift to Parting and Grooving tools.
- New: Units added to stock and work offsets in setup file.
- New: Select and delete multiple geometries as once in the machine builder.
- New: Turret tool mount STL and tool location can now be changed in the tool manager.
- New: Added generic machine with angle head.
- New: Added Engrave using Angle Head sample for Fanuc control.
- New: Angle heads can now be added to tool assemblies.

CIMCO Edit 2025.01.19

- New: Added show active plane and show current navigation to animation mode.
- New: Now shows tool name in simulation.

CIMCO Edit 2025.01.17

- New: Added a new "Pause Synchronization" option to pause automatic synchronization of all channels in Multi Channel view, preventing windows from jumping while editing NC files.

CIMCO Edit 2025.01.15

- New: Collision detection option added for static head models in the machine builder.

CIMCO Edit 2025.01.13

- New: Added 'jump to cut' feature.
- New: Added 'color toolpath by feedrate' feature.

CIMCO Edit 2025.01.12

- New: Sub-Spindle Offset setting.

CIMCO Edit 2025.01.11

- New: Stock transfer and dual spindle machine simulation support.
- New: Added ability to extract and open embedded NC programs from TRAUB WinFlex files. This setting is available in General Settings.
- New: Added --no-bring-to-front flag to prevent the editor from being brought to the foreground when called via command line. (S25874)
- New: Now shows the machine origin in machine builder.